

TECHNICAL MANUAL

**DIRECT SUPPORT AND GENERAL SUPPORT
MAINTENANCE MANUAL**

**AIR TRAFFIC CONTROL FACILITY
AN/TSQ-97
(NSN 5895-00-137-8548)**

HEADQUARTERS, DEPARTMENT OF THE ARMY

1 APRIL 1980

**This copy is a reprint which includes current
pages from Changes 1 and 2.**

WARNINGS

Storage Battery BB-451/U uses dangerous chemicals which can cause severe burns if personnel fail to observe safety precautions. Report to hospital or first aid station for treatment. Tell doctor you have been contaminated with Potassium Hydroxide (KOH).

To prevent Hydrogen gas explosion, remove Storage Battery BB-451/U from transit position and ventilate cabinet interior before activating radios.

DANGEROUS CHEMICALS ARE USED IN SILVER-ZINC BATTERIES

The electrolyte used in silver-zinc batteries (BB-4511/U used with this facility) contains potassium hydroxide (KOH), which is a caustic chemical agent. Serious and deep burns of body tissue will result if the electrolyte comes in contact with the eyes or any part of the body. Use rubber gloves, rubber apron, and protective goggles when handling the electrolyte. If accidental contact with the electrolyte is made, use ONLY clean water and immediately (seconds count) flush contaminated areas. Continue flushing with large quantities of clean water for at least 15 minutes. Seek medical attention without delay.

DO NOT MIX SULPHURIC ACID AND KOH

The electrolyte used in silver-zinc batteries (BB-4511U used with this facility) reacts violently to the sulphuric acid used in the more common lead-acid types of batteries. DO NOT add sulphuric acid electrolyte to the battery; the mixing of the acid and KOH electrolytes will cause a violent reaction which could result in the splattering of the mixture into the eyes and onto the skin. Every effort must be made to keep silver-zinc batteries as far away as possible from lead-acid batteries. Do not use the same tools and materials such as screwdrivers, wrenches, syringes, hydrometers, and gloves for both types of batteries. Any trace of acid or acid fumes will permanently damage silver-zinc batteries on contact.

WARNING

Adequate ventilation should be provided while using TRICHLOROTRIFLUOROETHANE. Prolonged breathing of vapor should be avoided. The solvent should not be used near heat or open flame; the products of decomposition are toxic and irritating. Since TRICHLOROTRIFLUOROETHANE dissolves natural oils, prolonged contact with skin should be avoided. When necessary, use gloves which the solvent cannot penetrate. If the solvent is taken internally, consult a physician immediately.

CHANGE

No. 2

HEADQUARTERS
DEPARTMENT OF THE ARMY
Washington, DC, 5 March 1985

**DIRECT SUPPORT AND GENERAL SUPPORT
MAINTENANCE MANUAL**

**AIR TRAFFIC CONTROL FACILITY AN/TSQ-97
(NSN 5895-00-137-8548)**

TM 11-5895-800-34, 1 April 1980, is changed as follows.

1. New or changed material is indicated by a vertical bar in the margin of the page.
2. Added or revised illustrations are indicated by a vertical bar in front of the figure caption.
3. Remove old pages and insert new pages as indicated below:

<i>Remove pages</i>	<i>Insert pages</i>
i through iii.....	i through iv
1-0.....	v and 1-0
1-1 and 1-2.....	1-1 and 1-2
2-3 through 2-12.....	2-3 through 2-12
None.....	2-12A/(2-12B blank)
2-15 and 2-16.....	2-15/(2-16 blank)
2-17 and 2-18.....	2-17/(2-18 blank)
2-19 and 2-20.....	2-19 and 2-20
None.....	2-20A/(2-20B blank)
2-21 and 2-22.....	2-21 and 2-22
None.....	2-22A/(2-22B blank)
2-23 and 2-24.....	2-23/(2-24 blank)
2-25 and 2-26.....	2-25 and 2-26
2-27 and 2-28.....	2-27/(2-28 blank)
2-29 and 2-30.....	2-29/(2-30 blank)
None.....	2-31/(2-32 blank)
None.....	2-33/(2-34 blank)
None.....	2-35 and 2-36
None.....	2-37/(2-38 blank)
None.....	2-38A/(2-38B blank)
None.....	2-39/(2-40 blank)
None.....	2-41 and 2-42
None.....	2-43/(2-44 blank)
3-3 and 3-4.....	3-3 and 3-4
None.....	3-4A/(3-4B blank)
3-5 through 3-8.....	3-5 through 3-8
3-11 and 3-12.....	3-11 and 3-12
None.....	3-14A/(3-14B blank)
3-15 through 3-24.....	3-15 through 3-24
None.....	FO-IA/(FO-I B blank)
FO-3/(FO-4 blank).....	FO-3/(FO-4 blank)
FO-9/(FO-10 blank).....	FO-9/(FO-10 blank)
FO-15/(FO-16 blank).....	FO-15/(FO-16 blank)

4. File this sheet in the front of the manual for reference purposes.

By Order of the Secretary of the Army:

JOHN A. WICKHAM JR.
General, United States Army
Chief of Staff

Official:

DONALD J. DELANDRO
Brigadier General, United States Army
The Adjutant General

DISTRIBUTION:

To be distributed in accordance with DA Form 12-36B, Direct and General Support Maintenance requirements for AN/TSQ-97.

CHANGE }
No. 1 }

HEADQUARTERS
DEPARTMENT OF THE ARMY
WASHINGTON, DC, 28 May 1982

**Direct Support and General Support
Maintenance Manual
AIR TRAFFIC CONTROL FACILITY ANITSQ97
(NSN 589500-137-8548)**

TM 11-5895-800-34, 1 April 1980, is changed as follows:

1. New or changed material is indicated by a vertical bar in the margin of the page.
2. Added or revised illustrations are indicated by a vertical bar in front of the figure caption.
3. Remove and insert pages as indicated below.

<i>Remove</i>	<i>Insert</i>
i through 1-0	i through 14
1-1 and 1-2	1-1 and 1-2
2-1 through 2-29/2-30	2-1 through 2-30
3-1 and 3-.....	3-1 and 3-2
3-9 through 3-14	3-9 through 3-14
3-21 through 3-24	3-21 through 3-24
3-29 and 3-30	3-29 and 3-30
None.....	3-30A/3-30B
3-31 and 3-32	3-31 and 3-32
None.....	3-32A/3-32B
3-33 through 3-36	3-33 through 3-36
None.....	3-36A/3-36B
3-37 through 3-44	3-37 through 3-44
3-55 through 3-60	3-55 through 3-60
None.....	3-60A/3-60B
3-61 and 3-62	3-61 and 3-62
3-67 and 3-68	3-67 and 3-68
3-71/3-72	3-71 and 3-72
4-1 and 4-2	4-1 and 4-2
Appendix A	A-1/(A-2 Blank)
FO-31/FO-4 through FO-7/FO-8	FO-3/FO-4 through FO-7/FO-8
FO-13/FO-14 through FO-19/FO-20	FO-13/FO-14 through FO-19/FO-20
None.....	FO-21/FO-22 and FO-23/FO-24

4. File this change in front of the manual for reference purposes.

By Order of the Secretary of the Army:

Official:

E. C. MEYER
General, United States Army
Chief of Staff

ROBERT M. JOYCE
Brigadier General, United States Army
The Adjutant General

Distribution:

To be distributed in accordance with DA Form 12-36, Direct and General Maintenance requirements for AN/ARC-114, AN/ARC-I 15.

**DIRECT SUPPORT AND GENERAL SUPPORT
 MAINTENANCE MANUAL
 AIR TRAFFIC CONTROL FACILITY AN/TSQ97
 (NSN (5895-00-137-8548))**

REPORTING ERRORS AND RECOMMENDING IMPROVEMENTS

You can help improve this manual. If you find any mistakes or if you know of a way to improve the procedures, please let us know. Mail your letter, DA Form 2028 (Recommended Changes to Publications and Blank Forms), or DA Form 2028-2 located in back of this manual direct to Commander, US Army Communications-Electronics Command and Fort Monmouth, ATTN: AMSEL-ME-MP, Fort Monmouth, NJ 07703-5007.

In either case, a reply will be furnished direct to you.

		<i>Paragraph</i>	<i>Page</i>
CHAPTER	1. INTRODUCTION		
SECTION	I. General		
	Scope	1-1	1-1
	Consolidated Index of Army Publications and Blank Forms	1-2	1-1
	Maintenance Forms, Records, and Reports.....	1-3	1-1
	Reporting Equipment Improvement Recommendations (EIR)	1-3.1	1-1
	Destruction of Army Electronics Materiel -4.....	1-4	1-1
	Calibration	1-5	1-1
	II. Description and Data		
	General.....	1-6	1-2
	Major Assemblies	1-7	1-2
CHAPTER	2. FUNCTIONING OF EQUIPMENT		
SECTION	I. Capabilities		
	Introduction.....	2-1	2-1
	General.....	2-2	2-1
	Meteorological Capabilities	2-3	2-1
	General Discussion.....	2-4	2-1
	Functional Areas Described	2-5	2-3
	Test Points	2-6	2-3
	Basic Description and Analysis	2-7	2-4
	II. Block/Simplified Diagram Analysis of Major Functions		
	Power Distribution.....	2-8	2-8
	Transmit Audio	2-9	2-8
	Microphone Amplifier 1A1A2.....	2-10	2-10
	Receive Audio (Clear and X-Mode).....	2-11	2-10
	Headset Amplifier 1A3	2-12	2-12
	Lamp Indicator Circuit Board.....	2-13	2-12A
	Keying Circuits and Audio Disable	2-14	2-12A
	Control Monitor Interface	2-15	2-12A
	X-Mode Control Circuits.....	2-16	2-12A
	Baseband Diphas Select	2-17	2-19
	Wind Detector.....	2-18	2-19
	III. Circuit Analysis		
	Transmit (:Lear Audio and Control (Keying)	2-19	2-21
	Transmit X-Mode Signal (Fig 2-16, 2-20, 2-21).....	2-20	2-21
	Receive Clear Audio (Fig 2-17, 2-18)	2-21	2-25
	Receive Secure Signal	2-22	2-25
	Wind Speed and Direction Circuits	2-23	2-26
	MK-2225/TSQ-97 Installation Kit Power Distribution Panel.....	2-24	2-26

CHAPTER	3.	DIRECT SUPPORT MAINTENANCE INSTRUCTIONS		
SECTION	I.	General Instructions		
		Scope	3-1	3-1
		Organization of Troubleshooting Procedures	3-2	3-1
		Test Equipment, Tools and Accessories	3-3	3-2
		System Cabling.....	3-4	3-2
		Power Distribution Circuit Measurements.....	3-5	3-2
SECTION	II.	Troubleshooting		
		Direct Support Troubleshooting Procedures	3-6	3-7
		Wind Direction Signal Tests and Measurements	3-7	3-38
		Transmit Control and Audio Disable Tests and Measurements (NORM).....	3-8	3-38
	III.	Direct Support Maintenance		
		Scope of Maintenance	3-9	3-39
		26 Vac Adjustment	3-10	3-39
		Microphone Amplifier Adjustment	3-11	3-39
		Wind Speed Adjustment	3-12	3-39
		Remove and Replace Procedures.....	3-13	3-39
		Interior Access	3-14	3-39
		Replacing Plug-In Cards	3-15	3-39
		Replacing Control Board Assembly 1A1A7.....	3-16	3-39
		Replacing Interface Assembly 1A1A9A1	3-17	3-39
		Replacing Filter 1A1A9FL1	3-18	3-40
		Replacing Relay Board 1A1A12.....	3-18A	3-40
		Replacing Power Supply Assembly 1A1A11PS1	3-19	3-40
		Replacing Filter 1AFL1	3-19A	3-40
		Replacing Front Panel Parts	3-20	3-40
		Replacing Wind Direction Indicator 1D1.....	3-21	3-40
		Replacing WIND SPEED Meter	3-22	3-40
		Replacing Altimeter.....	3-23	3-40
		Replacing Clock.....	3-24	3-41
		Replacing BATTERY Meter	3-2	3-41
		Replacing SPKR-HDST Switch A1AS	3-26	3-41
		Radio 1,2,3 Circuit Breakers	3-27	3-42
		POWER OFF-ON Switch circuit Breaker CB4	3-28	3-42
		AudioTransformer 1 A1 A	3-29	3-42
		Lights MON4ONON Switch 1 A1 A8S5	3-30	3-42
		DIM Control 1 A AR	3-31	3-42
		VOL Control 1A1ASR1	3-32	3-42
		AUDIO Indicators A1 A8XDS 1,2,3.....	3-35	3-42
		XMT OFF-MON Switches 1A1A8S 1,2,3.....	3-34	3-42
		PUSH TO OPERATE Switch 1A1A8S6.....	3-35	3-42
		XMT-MODE Switch 1A1A8S6.....	3-36	3-42
		Keying Relay 1A1A8K1.....	3-36A	3-43
SECTION	IV.	Direct Support Performance Standard Testing Procedures		
		General.....	3-37	3-45
		Test Procedures.....	3-38	3-45
CHAPTER	4.	GENERAL SUPPORT MAINTENANCE		
		Scope	4-1	4-1
		Tool, Materials and Test Equipment Required	4-2	4-1
		Disassembly and Reassembly of Wind Direction and Speed Detector		
		ML-653ISQ-97 (Fig. 4-1).....	4-3	4-1
		Wind Speed Adjustment Procedure	4-4	4-2
		Wind Direction Alignment Procedures.....	4-5	4-2
APPENDIX	A..	REFERENCES		A-1
APPENDIX	B.	EXPENDABLE SUPPLIES AND MATERIALS LIST		
SECTION	I.	INTRDUCTION.....		B-1
	II.	TABULAR LISTING		B-2

LIST OF ILLUSTRATIONS

Figure	Title	Page
1-1	Air Traffic Control Facility AN/TSQ-97 Assembled for Operation (Sheets 1 and 2)	v
2-1	ANITSQ-97 Simplified Overall Block Diagram	2-2
2-2	Control-Monitor Internal Interface	2-5
2-3	Radio To Control-Monitor Interface	2-6
2-4	Power Distribution	2-9
2-5	Transmit Audio, Simplified Block Diagram	2-10
2-6	Microphone Amplified 1A1A2 Schematic Diagram	2-11
2-7	Receive Audio. Simplified Block Diagram	2-12
2-8	Headset Amplified Board, Schematic Diagram	2-13
2-9	Lamp Indicator Circuit Boards 1A1A4, AS5, A6, Schematic Diagram	2-14
2-10	Keying Circuits and Audio Disable, Block Diagram	2-14
2-11	Control Monitor/TSEC/KY-38 Interface.....	2-15
2-11A	Control Monitor/TSEC/KY-57 Interface.....	2-17
2-12	X-Mode Control Circuit Using TSEC/KY-38 Security Equipment	2-19
2-12A	X-Mode Control Circuit Using TSEC/KY-57 Security Equipment	2-20
2-13	Base Band/DI Phase Select Using TSEC/KY-38 Security Equipment, Simplified Block Diagram	2-20
2-13A	Base Band/DI Phase Select Using TSEC/KY-57 Security Equipment, Block Diagram	2-20A
2-14	Wind Detector Circuits, Simplified Block Diagram	2-20A
2-15	Transmit Audio, Simplified Signal Flow Diagram	2-22
2-16	Transmit Audio (X-Mode) Using TSEC/KY-38 Security Equipment, Simplified Functional Diagram	2-22A
2-16A	Transmit Audio (X-Mode) Using TSEC/KY-57 Security Equipment, Simplified Functional Diagram	2-23
2-17	Receive Audio, Simplified Signal Flow Diagram	2-27
2-18	Receive Mode, With TSEC/KY-38 Security Equipment, Simplified Functional Diagram ..	2-29
2-18A	Receive Mode, With TSEC/KY-57 Security Equipment, Simplified Functional Diagram ..	2-31
2-19	Keying Circuits and Audio Disable (Sheets 1 and 2)	2-33
2-20	X-Mode Control Circuits, With TSEC/KY-38 Security Equipment, Simplified Signal Flow Diagram	2-36
2-20	X-Mode Control Circuits, With TSEC/KY-57 Security Equipment, Simplified Signal Flow Diagram	2-37
2-21	Base Band/DI Phase Select, Simplified Signal Flow Diagram	2-38A
2-21	Base Band/DI Phase Select Using TSEC/KY-57 Security Equipment, Simplified Signal Flow Diagram	2-39
2-22	Wind Detector Circuit, Simplified Signal Flow Diagram	2-41
2-23	MK-222/TSQ-97 Installation Kit Power Distribution Panel, Schematic Diagram	2-43
3-1	Control Monitor C-9921/TSQ-97 (Unit 1A1) Rear Interior View	3-2
3-2	Resistor Pad	3-15
3-3	Control Monitor Front Panel Parts, Mounting Configuration, Rear View	3-41
4-1	Wind Direction and Speed Detector, ML-653/TSQ-97, Exploded View	4-3
4-2	Wind Speed Adjustment Connections	4-4
4-3	Wind Direction Alignment Fixture	4-5

Foldout Diagrams

FO-1	Cabling Diagram AN/TSQ-97 System
FO-1A	Cabling Diagram MK-2226/TSQ-97 Installation Kit
FO-2	Composite Electrical Schematic Diagram, Control Monitor C-9921/TSQ-97 (Sheets 1, 2, and 3)
FO-3	Electrical Schematic Diagrams for AN/TSQ-97 System Cables, MK-2225/TSQ-97 Installation Kit Cables, 50 Foot Power Cable, ML653/TSQ-97 and Choke MX-9713f/TQ-97
FO-4	Electrical Schematic Diagram, Rear Panel Assembly I A1 A9
FO-5	Electrical Schematic Diagram. Card Enclosure Assembly 1 A1A1
FO-6	Electrical Schematic Diagram, Interface Circuit Board Assembly 1A1A19
FO-7	Electrical Schematic Diagram, Front Panel Assembly 1A1A8
FO-8	Electrical Schematic Diagram, Control Board Assembly 1A1A7 (Earlier Systems)
FO-9	Electrical Schematic Diagram, Control Board Assembly 1A1A7 (Later Systems)
FO-10	Electrical Schematic Diagram, Relay Board Assembly 1A1A12

LIST OF TABLES

<i>Table</i>	<i>Title</i>	<i>Page</i>
2-1	Order of Discussion	2-3
3-1	Test Equipment, and Tools	3-3
3-2	Cable Schematic Diagrams	3-3
3-3	Power Distribution Network Resistance Measurements	3-4A
3-4	Voltage Measurements.....	3-6
3-5	Troubleshooting Chart.....	3-8
3-5A	Cable Continuity Checks	3-14A
3-6	Radio 1 Position, Receive Clear Audio Signal Tests and Measurements	3-15
3-7	Radio 2 Position, Receive Clear Audio Signal Tests and Measurements	3-17
3-8	Radio 3 Position, Receive Clear Audio Signal Tests and Measurements	3-18
3-9	Radio 1 Position, Receive Secure Signal (Cipher Text) Test and Measurements	3-20
3-10	Radio 2 Position, Receive Secure Signal (Cipher Text) Tests and Measurements	3-22
3-11	Radio 3 Position, Receive Secure Signal (Cipher Text) Tests and Measurements	3-23
3-12	Radio 1 Position, Transmit Clear Audio Signal Tests and Measurements	3-25
3-13	Radio 2 Position, Transmit Clear Audio Signal Tests and Measurements	3-27
3-14	Radio 3 Position, Transmit Clear Audio Signal Tests and Measurements	3-28
3-15	Radio 1 Position, Secure Transmit Signal Tests and Measurements	3-29
3-16	Radio 2 Position, Secure Transmit Signal Tests and Measurements	3-32
3-17	Radio 3 Position, Secure Transmit Signal Tests and Measurements	3-34
3-18	Power Output Tests.....	3-36
3-19	Wind Speed Circuit Tests.....	3-37
3-20	Transmit Control (NORM) and Audio Disable Tests and Measurements	3-38
3-21	Wiring Chart for X-OFF-MON Switches.....	3-43
3-22	Wiring Chart for XMT-MODE Switch	3-44
3-23	Power Distribution, Performance Standard, Test Procedures	3-45
3-24	Receive Audio (Clear), Performance Standard Test Procedures	3-48
3-25	Receive X-Mode Signal, Performance Standard Tests	3-55
3-26	Transmit Audio (Clear), Performance Standard Test Procedures	3-62
3-27	Transmit X-Mode Signal, Performance Standard Tests	3-67

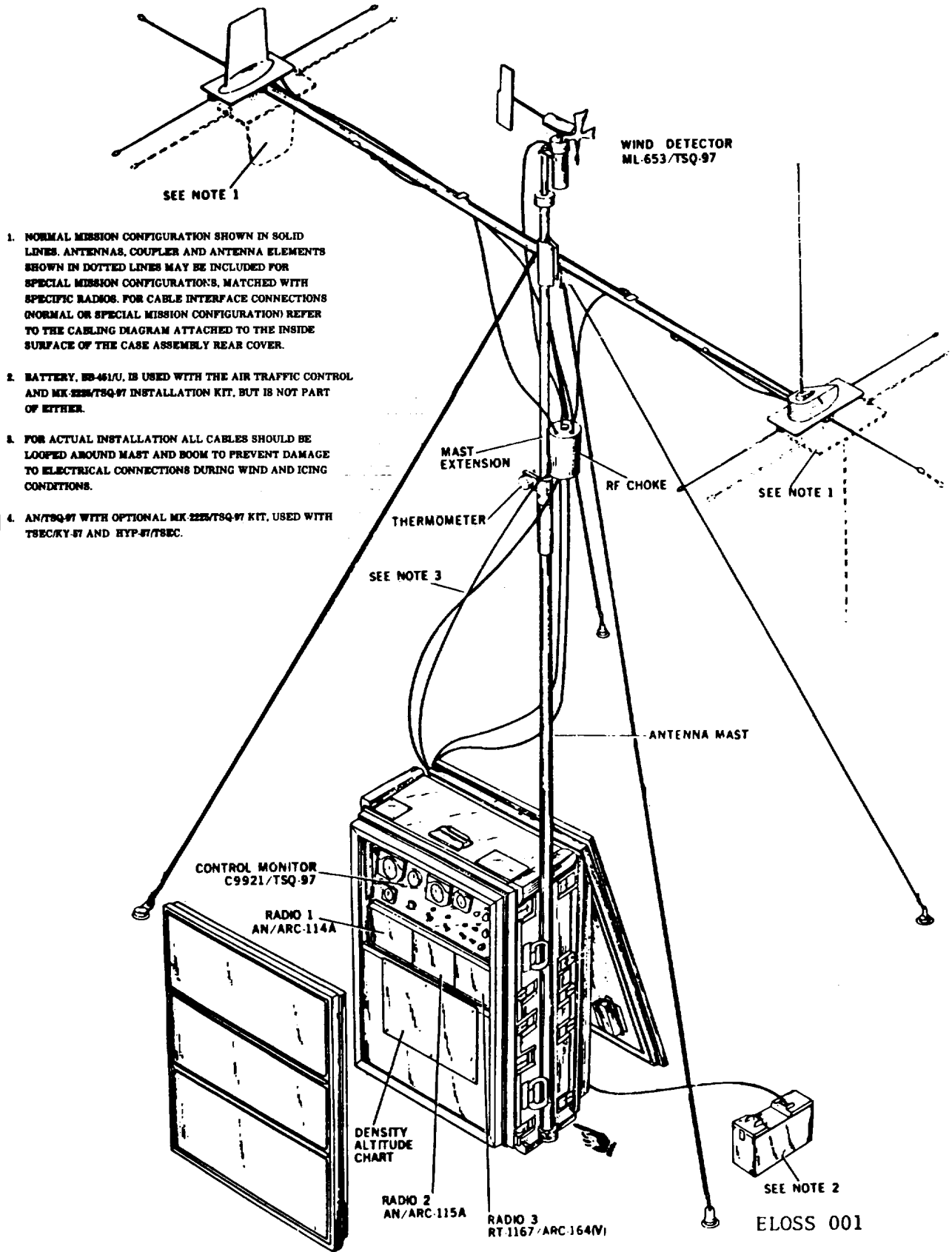

1. NORMAL MISSION CONFIGURATION SHOWN IN SOLID LINES. ANTENNAS, COUPLER AND ANTENNA ELEMENTS SHOWN IN DOTTED LINES MAY BE INCLUDED FOR SPECIAL MISSION CONFIGURATIONS, MATCHED WITH SPECIFIC RADIOS. FOR CABLE INTERFACE CONNECTIONS (NORMAL OR SPECIAL MISSION CONFIGURATION) REFER TO THE CABLING DIAGRAM ATTACHED TO THE INSIDE SURFACE OF THE CASE ASSEMBLY REAR COVER.
2. BATTERY, EB-461/U, IS USED WITH THE AIR TRAFFIC CONTROL AND MK-222/TSQ-97 INSTALLATION KIT, BUT IS NOT PART OF EITHER.
3. FOR ACTUAL INSTALLATION ALL CABLES SHOULD BE LOOPED AROUND MAST AND BOOM TO PREVENT DAMAGE TO ELECTRICAL CONNECTIONS DURING WIND AND ICING CONDITIONS.
4. AN/TSQ-97 WITH OPTIONAL MK-222/TSQ-97 KIT, USED WITH TSEC/KY-87 AND HYP-87/TSEC.

Figure 1-1. Air Traffic Control Facility AN/TSQ-97 ()
Assembled for Operation (Sheet 1 of 2)

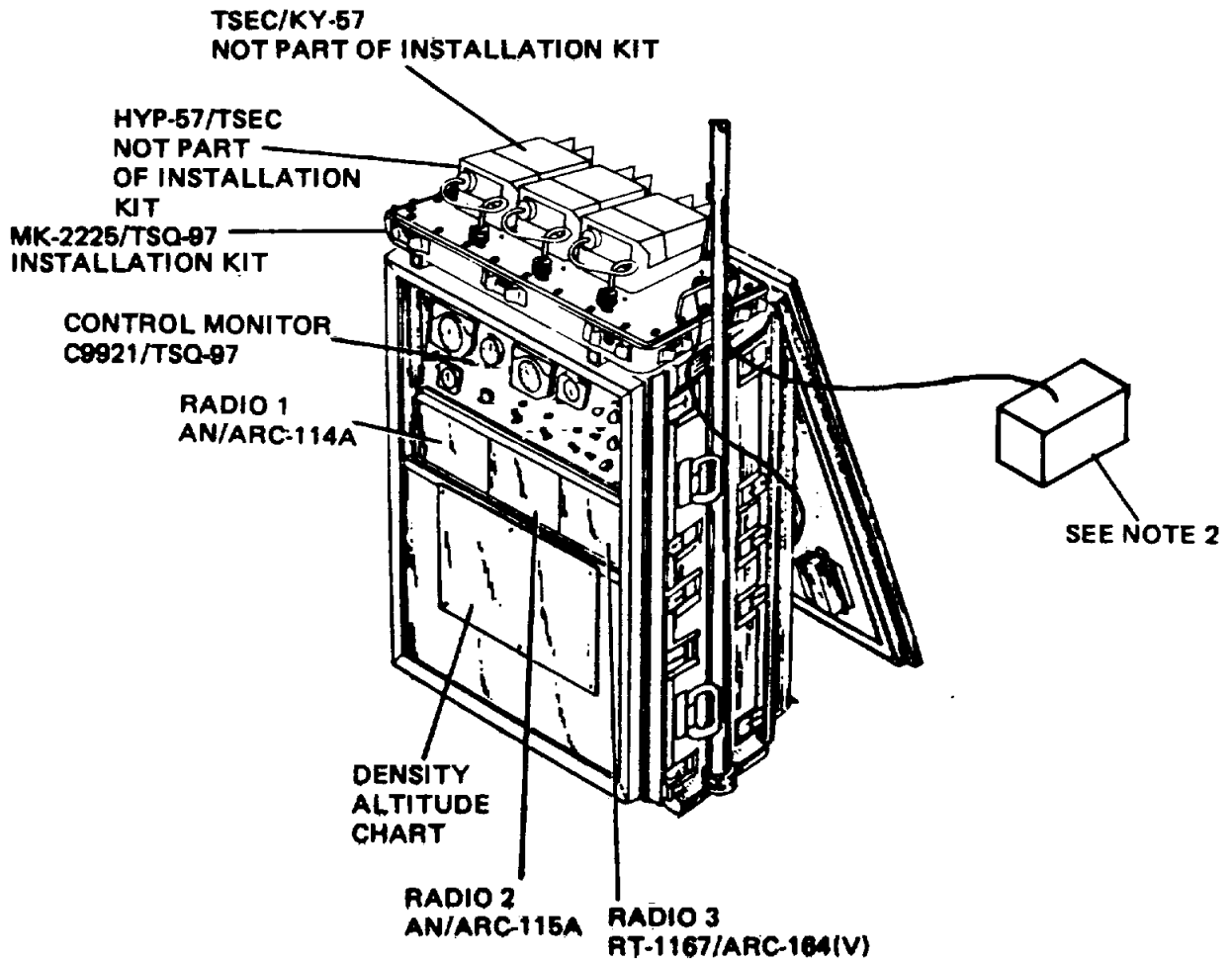

SEE NOTE 4

Figure 1-1. Air Traffic Control Facility AN/TSQ-97 ()
Assembled for Operation (Sheet 2)

Change 2 1-0

CHAPTER 1 INTRODUCTION

Section I. General

1-1. Scope

This technical manual contains instructions for Direct Support (DS) and General Support (GS) for the Air Traffic Control Facility AN/TSQ-97 shown in figure 1-1 and hereinafter referred to as the facility. Included are procedures for fault isolation, troubleshooting, adjustments, disassembly, replacement of authorized maintenance parts, and assembly. Also described are the test equipment required for DS and GS maintenance. Information is also included on the MK-2225/TSQ-97 Installation Kit which is used to interface TSEC/KY-57 security equipment with the AN/TSQ-97 facility. Refer to TM 11-5895-800-12 for descriptive data and operation instructions for the facility.

1-2. Consolidated Index of Army Publications and Blank Forms

Refer to the latest issue of DA Pam 310-1 to determine whether there are new editions, changes, or additional publications pertaining to the equipment.

1-3. Maintenance Forms, Records and Reports

a. Reports of Maintenance and Unsatisfactory Equipment. Department of the Army forms and procedures used for equipment maintenance will be those prescribed by DA Pam 738-750 as contained in Maintenance Management Update.

b. Report of Packaging and Handling Deficiencies. Fill out and forward SF 364 (Report of Discrepancy (ROD)) as prescribed in AR 735-11-2/DLAR 4140.55/INAVMATINST 4355.73A/AFR 400-54/MCO 4430.3F.

c. Discrepancy in Shipment Report (DISREP) (SF 361). Fill out and forward Discrepancy in Shipment Report (DISREP) (SF 361) as prescribed in AR 55-38/NAVSUPINST 4610.33C/AFR 75-18/MCO P46101.19D/DLAR 4500.15.

1-3.1. Reporting Equipment Improvement-Recommendations (EIR)

If your Air Traffic Control Facility AN/TSQ-97 needs improvement, let us know. Send us an EIR. You, the user, are the only one who can tell us what you don't like about your equipment. Let us know why you don't like the design. Put it on an SF 368 (Quality Deficiency Report). Mail it to Commander, US Army Communications-Electronics Command and Fort Monmouth, ATTN: AMSEL-ME-MP, Fort Monmouth, New Jersey 07703-5007. We'll send you a reply.

1-4. Destruction of Army Electronics Materiel

Destruction of Army electronics materiel to prevent enemy use shall be in accordance with TM 750-244-2.

1-5. Calibration

This equipment only requires calibration of the wind speed function and microphone amplifier gain. See paragraphs 3-11, 3-12, and 4-4. The MK-2225/TSQ-97 installation kit used for TSEC/KY-57 interface requires no calibration.

Section II. DESCRIPTION AND DATA

1-6. General. For the general description of the facility refer to Operators and Organizational Maintenance Manual TH 11- 5895-800-12. The Control Monitor C-9921/TSQ-97 is the primary item requiring DS or GS maintenance, therefore the bulk of the text of this manual concerns testing, troubleshooting and re- pair of the control monitor. The Wind Direction and Speed De- tector ML-653/TSQ-97 is repairable at general support. See Chapter 4. The Control Monitor C-9921/TSQ-97 consists of a front panel containing the meteorological indicators, switches, operator controls and associated

wiring, a back panel, piggy back input circuit boards (input filters and control circuits) internal wiring and connectors. A card enclosure contains five removable printed circuit cards. All internal circuitry and components are accessible by loosening 8 wing fasteners on the hinged rear panel, and lowering the panel.

1-7. Major Assemblies. The reference designation numbers assigned to the major assemblies are as follows:

Reference No	Name	Part No.
	Air Traffic Control Facility AN/TSQ-97	DL-SC-B-706000
1	Group Assembly OA-8879/TSQ-97	DL-SC-B-706003
1A1	Control Monitor C-9921/TSQ-97	DL-SC-B-706165
1A1A1	Card Enclosure	DL-SC-B-706186
1A1A2	Microphone Amplifier Board Assembly	DL-SC-B-706200
1A1A3	Headset Amplifier Board Assembly	DL-SC-B-706195
1A1A4	Lamp Indicator Board Assembly (radio I)	DL-SC-B-706205
1AA5	Lamp Indicator Board Assembly (radio a	DL-SC-B-706205
1A1A6	Lamp Indicator Board Assembly (radio3)	DL-SC-B-706205
1A1A7	Control Board Assembly	DL-SC-B-706228
1A1A8	Front Panel Assembly	SC-D-706214
1A1A9	Rear Panel Assembly	SC-D-706223
1A1A9A1	Interface Board Assembly	DL-SC-B-706233
1A1A10	Speaker Assembly	SC-C-706188
1AA11	26 VAC Power Supply Assembly	SC-D-706279
1A1A12	Relay Board Assembly	DL-SC-B-706050
1A1FL1	Filter	SC-A-706170

Change 1 1-2

CHAPTER 2 FUNCTIONING OF EQUIPMENT

Section I. CAPABILITIES

2-1. Introduction

This chapter analyzes the Air Traffic Control Facility AN/TSQ 97, to the extent required to enable maintenance personnel to understand how each major circuit functions. Signal flow, as related to individual major functions within the equipment, is discussed, first by basic block diagrams, then simplified signal flow. Composite schematic diagrams are located in the back of this manual. Maintenance and troubleshooting for the individual radio sets are contained in the applicable technical manual listed in appendix A of this manual.

2-2. General

The Air Traffic Control Facility AN/TSQ 97 is a four person portable communications facility used where needed to communicate with on ground and in flight aircraft. Communications in the VHF and UHF ranges is accomplished by using three standard lightweight avionics equipment radios (transceivers), which can be switched from transmit/receive to receive only for both clear and X mode (cipher text) communications. Figure FO 1 is a cabling diagram showing the facility equipment interface. The facility control device (Control Monitor C 9921/TSQ 97) provides interface, control and processing for the receive and transmit audio. The modes of operation are:

- Clear Receive (MON) see 2 21
- X Mode Receive (MON) see 2 22
- Clear Transmit (XMT) see 2 19
- X Mode Transmit (XMT) see 2 20

2-3. Meteorological Capabilities

The facility meteorological equipment consists of a wind speed and direction determining device, ML 653/TSQ 97 (wind detector), that contains an impeller driven dc generator which generates an output proportional to wind speed. Wind speed is resolved into a knots indication on the front panel WIND SPEED meter. A synchro in the transmitter in the main housing of the detector generates a signal which is resolved to a wind direction reading on a front panel mounted meter. A thermometer mounted on the antenna mast during operation is used to determine the temperature of the site and for density altitude computation from a chart mounted on the front of the case below the control monitor. An AAU 8/A altimeter mounted in the front panel provides a barometric pressure indication for the site of operation.

2-4. General Discussion

Figure 2 1 is a simplified block diagram of the facility less items mounted on the antenna boom. All connections from devices on the antenna boom are interfaced through an RF choke attached to the mast, wherein the ground lines (shields) are filtered from the active lines to attenuate unwanted RF currents conducted along these paths. The control monitor provides a connection for the MC 80C/U microphone or H 337/TSQ 97 headset microphone for audio (modulation) input and provides circuitry for transmitter keying and disabling audio from radios not keyed. Front panel switches provide internal

Change 1 2-1

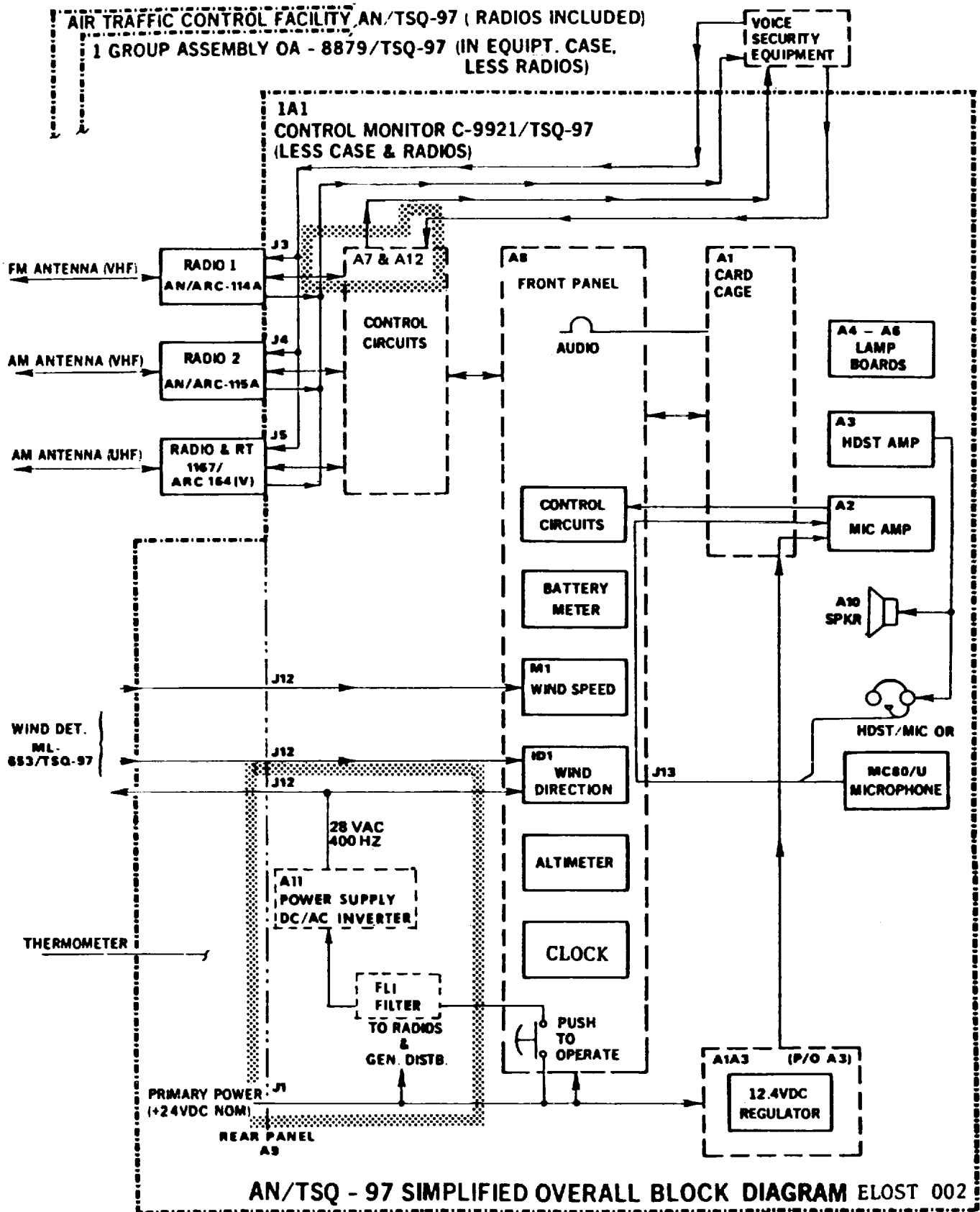

Figure 2-1. AN/TSQ-97 Simplified Overall Block Diagram

switching for control or selection as follows; note the complete description of front panel controls are contained in TM 11-5895-800-12:

- a. Control-monitor and radio front panel lighting (variable brightness, on and momentary on).
- b. Selection of speaker and headset or only headset to monitor audio.
- c. Primary power application.
- d. Select mode of operation for each radio (XMT/OFF/MON) and selects clear or X-mode processing circuitry.
- e. Applies 26 VAC to energize the wind direction synchro transmitter and receiver.
- f. An 8-day movement, mechanical wind, real time clock with stop watch function is mounted on the control monitor panel.

2-5. Functional Areas Described. The approach taken is to describe the major functions and sub-

functions listed in table 2-1 to enable the technician to understand signal flow as related to a specific function for fault isolation.

2-6. Test Points. Test points for oscilloscope or meter readings are provided on microphone amplifier board 1A1A2, headset amplifier board 1A1A3 and on the lamp indicator cards 1A1A4, As, A6. Test points on terminal board 1AITB1 (see figure 3-1) can be used to measure:

- a. +24 vdc to ac inverter 1A1A11.
- b. 26 vac output from 1A1A11.
- c. Audio to speaker 1A1A10.

NOTE

By analyzing the simplified signal flow of the function in question, and making measurements at the test points, fault sectionalizing and isolation is relatively easy.

Table 2-1. Order of Discussion

Topic	Paragraphs		Reference Figure	
	Basic	Circuit Analysis	Basic	Circuit Analysis
Control-Monitor Internal Interface	2-7		2-2	
Radio to Control-Monitor Interface	2-7		2-3	
Power Distribution	2-8		2-4	
Transmit Audio	2-9	2-19	2-5	2-15
Transmit Audio (X-Mode) Simplified Functional Diagram	2-17	2-20	2-15	2-16,2-20 2-21
Microphone Amplifier 1A1A2	2-10		2-6	
Receive Audio (Clear and X-Mode)	2-11	2-21,2-22	2-7	2-17

Table 2-1. Order of Discussion (Cont)

Topic	Paragraphs		Reference Figure	
	Basic	Circuit Analysis	Basic	Circuit Analysis
Receive Mode, Functional Diagram	2-11	2-21,2-22	2-7	2-18,2-18A
Headset Amplifier Circuit Board 1A1A3	2-12	-----	2-8	-----
Lamp Indicator Circuit Board 1A1A4-A6	2-13	-----	2-9	-----
Keying Circuits and Audio Disable	2-14	2-19a, 2-21	2-10	2-19
Control-Monitor/Security Equipment Interface	2-15	-----	2-11 2-11A	2-11,2-11A
X-Mode Control Circuits	2-16	2-20	2-12 2-12A	2-16,2-16A 2-20,2-20A 2-21,2-21A
Base Band/DI Phase Select	2-17	2-20	2-13 2-13A	2-21,2-21A 2-16,2-16A
Wind Detector and Display Circuits	2-18	2-23	2-14	2-22

2-7. Basic Description and Analysis.

Figure 2-2 shows how the control monitor interfaces connectors and plugs internally. All rear panel input/output connectors, except POWER IN 1A1A9J1 and SUPPRESSOR connector 1A1A9J2 are interfaced through a circuit board (1A1A9AI) that provides a 3300 PF filter capacitor to ground for each line. The filter board is interfaced to control board 1A1A7 for internal routing and impedance matching and to switching circuits. Relays on the control board are energized by front panel controls or in some circuits a specific relay may be energized by the (external) TSEC/

KY-38, or TSEC/KY-57 secure voice equipment, when it is connected. Amplification of the microphone signal, headset audio amplification and lighting circuit control for the associated radio AUDIO light is provided by removable circuit cards contained in card enclosure 1A1A1. Composite electrical schematic diagram, figure FO-2, showing circuit paths for all radios, is located at the back of this manual. Figure 2-3 identifies each radio line interfaced to the associated connectors on the control monitor, and refers each line to a simplified signal flow drawing where the associated function is shown in detail.

CONTROL MONITOR INTERNAL INTERFACE

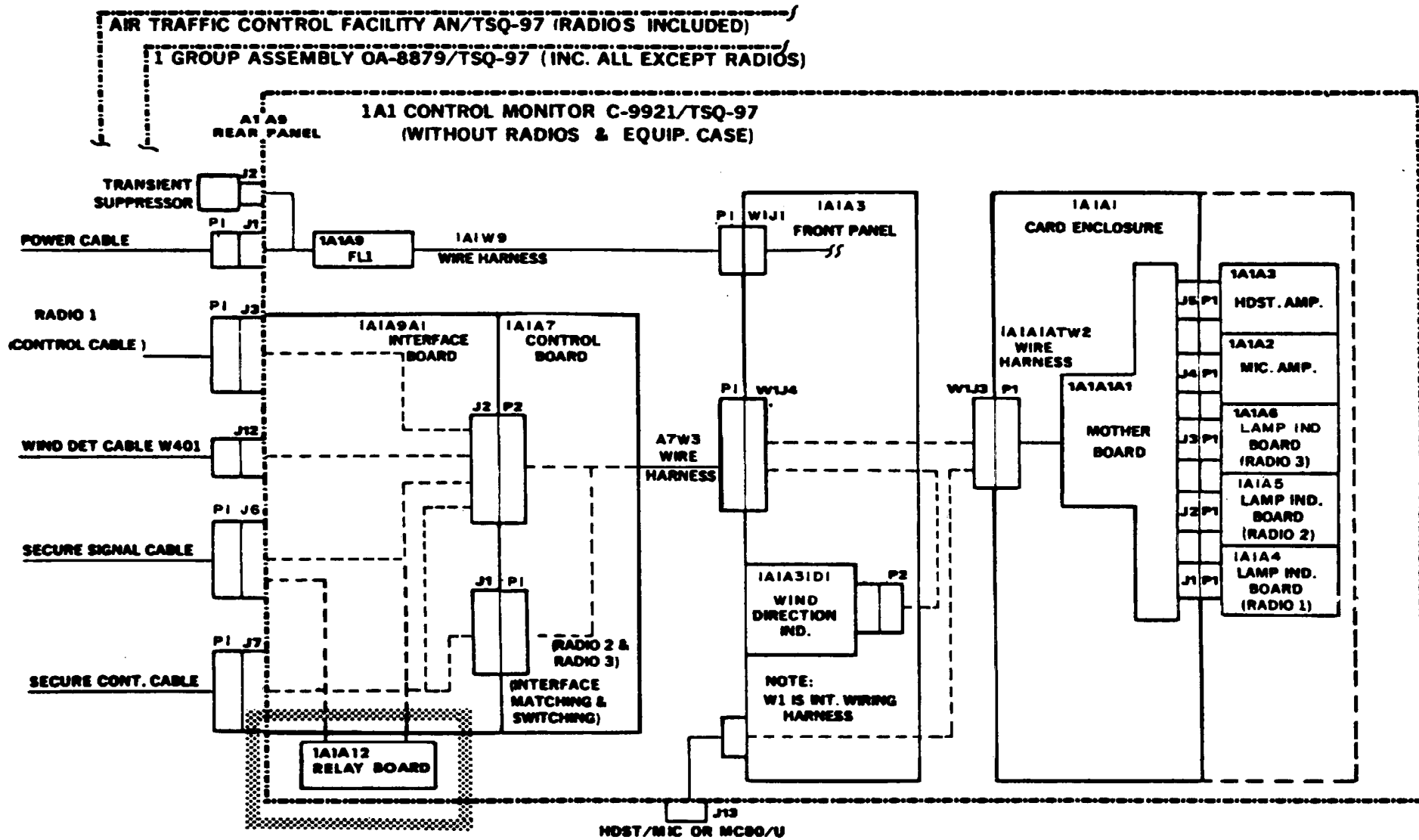

Figure 2-2. Control-Monitor Internal Interface

ELOST 003

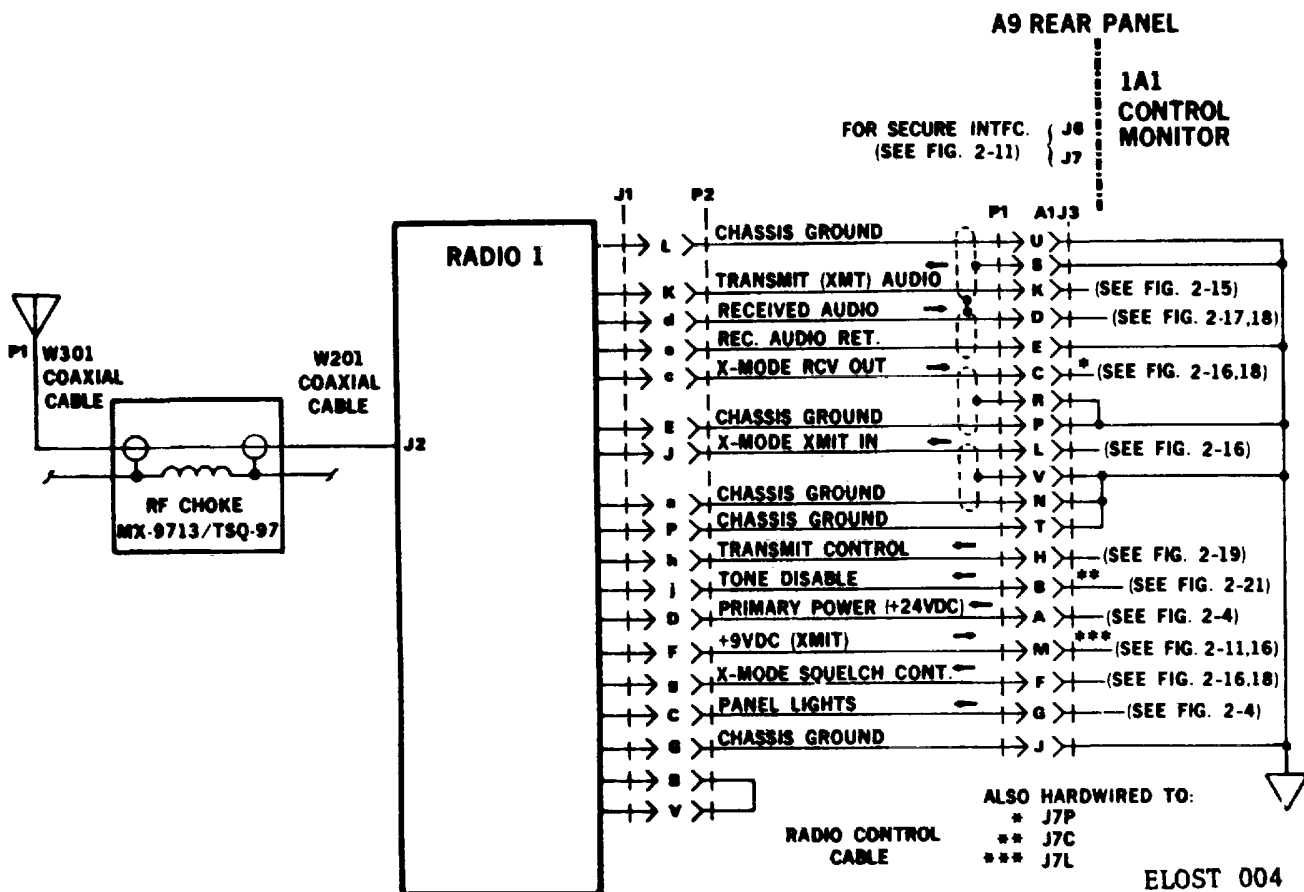

Figure 2-3. Radio to Control-Monitor Interface

a. Control Board 1A1A7, Basic Circuit Descriptions. Essentially, the control board circuits can be divided into four separate switching, matching and control circuits for each radio. The circuits associated with individual radios are similar, only circuit pin in/out and reference designators are different.

(1) X-mode control. A relay, 1A7K10, is common to all radio audio input lines. When using X-mode equipment, in cipher, with SECURE RADIO 1, SECURE RADIO 2, or SECURE RADIO 3 selected, the relay is energized which results in an additional 22K ohms of resistance to be inserted into the microphone audio input circuit and with the keying line grounded also grounds the X-mode control line to the radio selected.

(2) Transmit audio switching. Relay 1A1A7K3, K6 or K9 when energized on SECURE RADIO 1, SECURE RADIO 2, or SECURE RADIO 3, switches the applied audio to the TSEC/KY-38 or TSEC/KY-57 for encoding prior to application to the radio selected for X-mode operation.

(3) Receive audio switching. Receive audio switching relay 1A1A7K2, KS, or K8 is automatically energized, when the secure voice equipment is connected. Clear audio or cipher text is furnished from the radios to the secure voice equipment. If the system is in clear, the original clear audio, or if the system is in cipher, the deciphered (clear) audio is then returned through secure disable relays 1A1A12K1, K2 or K3 and the energized contacts of 1A1A7K2, KS, or K8 to the normal audio path. If the system is in normal and

secure equipment is not present, the clear audio is routed through the normally closed contacts of 1A1A7K2, K5S, or K8 to the normal audio path. The normal audio path is considered starting at the lamp indicator boards 1A1A3, A4, or A5.

(4) *Base band/DI phase select.* Transistor 1A1A7Q1 and relay 1A1A7K1 or 1A1A7Q2 and 1A1A7K4 or 1A1A7Q3 and 1A1A7K7, when energized from the +9V line from the AN/ARC-114A only, switch from diphas to base band coding.

(5) *Audio disable.* The receive audio path for each radio goes through a normally closed set of contacts on the associated audio disable relay (1A1A7K12, K13, or K11). When a radio set is keyed, the keyline, via steering diodes and transistor action, causes the audio paths for the not keyed radios to open by energizing the audio disable relay for those radios which opens the normally closed contacts.

b. *Relay Board 1A1A12 Circuits.* Relays 1A1A12K1, K2, and K3 are secure audio disable relays. Keying line grounds to individual relays activate and interrupt the cipher text from the radio positions not in transmit (keyed) condition, example: Radio position 1 is keyed, its keying line ground will activate 1A1A12K2, and K3 opening the input cipher text lines from positions 2 and 3.

c. *Front Panel 1A1A8 Circuits.* The front panel contains rotary, toggle and pushbutton switches, wiring and indicators.

(1) *X-mode control.* Switch 1A1A8S6 is a three-deck, four position rotary switch identified on the front panel as XMT MODE. The associated panel marking for the four positions are NORM, SECURE RADIO 1, SECURE RADIO 2, and SECURE RADIO 3. When set to NORM, the keying line is routed through the XMT-OFF-MON to any radio operating in the XMT

mode, and to the audio disable logic. When any SECURE position is selected and the PLAIN/CIPHER switch on the TSEC/KY-38 is in CIPHER (which provides ground to J7-M) or the MODE switch on the TSEC/KY-57 is in C, the X-mode control relay 1A1A7K10 is energized. Relay 1A1A7K10 and the keying relay 1A1A8K1 when energized ground the radio X-mode control lines. The associated XMT AUDIO relay is also energized to transfer microphone audio to the voice security equipment for encoding prior to application to the radio.

(2) *Transmit/receive control.* There are three, tri-position switches, one for each radio. The panel marking is XMT-OFF-MON. When positioned to MON or XMT, the receive audio is routed via one section of the switch, to the VOL control which supplies the headset amplifier that supplies audio to the output device selected. This is because the receive audio and the transmitter sidetone use the same audio path to the output device. When positioned to XMT, the keyline is routed to the security equipment or directly to the radio(s) being operated in XMT mode. When positioned to OFF, the radio is still energized, however the keyline and the audio path are opened by relay action.

(3) *Output device selection.* When the SPKR-HDST/HDST switch 1A1A8S4 is set to SPKR/HDST, the audio applied to the headset is also applied through a parallel audio transformer to the loudspeaker. See figures 2-7, 2-17

(4) *AUDIO indication.* The AUDIO indicators located above the XMT-OFF- MON switches indicate which radio is receiving a signal, or when a transmitter sidetone is present. The sidetone generated when a transmitter is keyed, follows the same path as received audio.

d. *Circuit Cards.* Card cage 1A1A1 contains five removable circuit cards associated with control and conditioning of the input/output audio

(1) *Microphone amplifier 1A1A2.* This circuit consists of two microcircuit linear amplifiers and attendant circuitry for amplification of the microphone signal. The gain is adjustable to 1350 minimum. Test points are provided to monitor

- Audio input
- Audio output from first amplifier stage
- Final audio output from circuit board
- Applied +12.4 VDC (from headset amplifier regulator section)

(2) *Headset amplifier circuit board 1A1A3.* The circuitry on this board has two basic functions. Audio outputs from the radios are amplified and applied to the HDST MIC connector (J13). Also a microcircuit linear voltage regulator supplies operating voltage for this board and for the microphone amplifier board. Test points are provided to monitor:

- Input Voltage (+24 VDC)
- Output Voltage (+12.4 VDC)
- Audio Input
- Audio Output

(3) *Lamp indicator board IAIA4 - 1AIA6.* This circuit board, one for each radio audio processing path provides in/out isolation for a common headset amplifier and a transistor- switch ground which lights the associated AUDIO light when the audio is routed through the board. Test points are provided to monitor:

- Audio Input
- Audio Output
- Action of Lamp Transistor Switch

Section II. BLOCK/SIMPLIFIED DIAGRAM ANALYSIS OF MAJOR FUNCTIONS

2-8. Power Distribution. Figure 2-4 shows how the primary power is distributed within the control monitor. The facility is designed to operate from 24 vdc. The input power can be supplied by Storage Battery BB-451/U. 24 vdc vehicular power or a dc power supply capable of supplying 24 vdc at 10 amps. The input power is applied to the AN/TSQ-97 through rear panel connector J1. If vehicular power is used, a transient suppressor must be connected to connector J2. The input power is connected to an RF filter and then to a front panel mounted BATTERY monitor meter. The battery voltage is continuously monitored by this meter. Next the power is connected to front panel POWER ON/OFF circuit breaker CB4. With POWER circuit breaker CB4 in the ON position, 24 volts is supplied to the LIGHTS ON/OFF switch,

SS; RADIO indicator lights DS1, DS2, and DS3; PUSH TO OPERATE switch for wind detection circuits; lamp indicator circuits; headset amplifier circuits; XMT MODE switch, S6; control board; and rear panel mounted radio circuit breakers CBI, CB2, and CB3. The headset amplifier circuit includes a 12 vdc regulator which supplies operating voltage for integrated circuits in the headset amplifier and microphone amplifier.

2-9. Transmit Audio. Block diagram figure 2-5 shows the transmit audio simplified signal flow. Audio output from the microphone is internally routed to the microphone amplifier board IAIA2 for amplification to a usable level. The resultant output is applied through switches and relay contacts directly to the radio

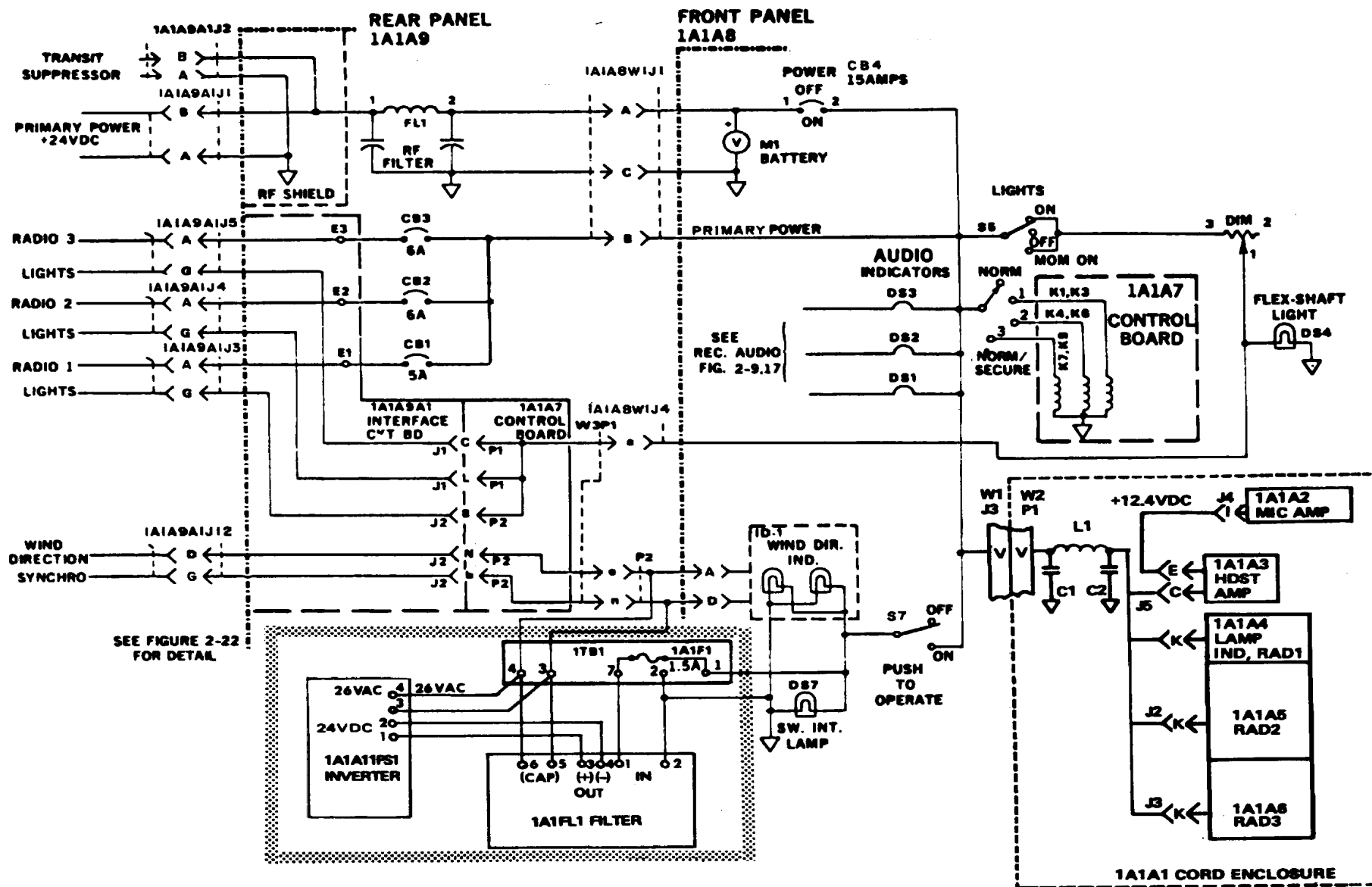

Figure 2-4. Power Distribution

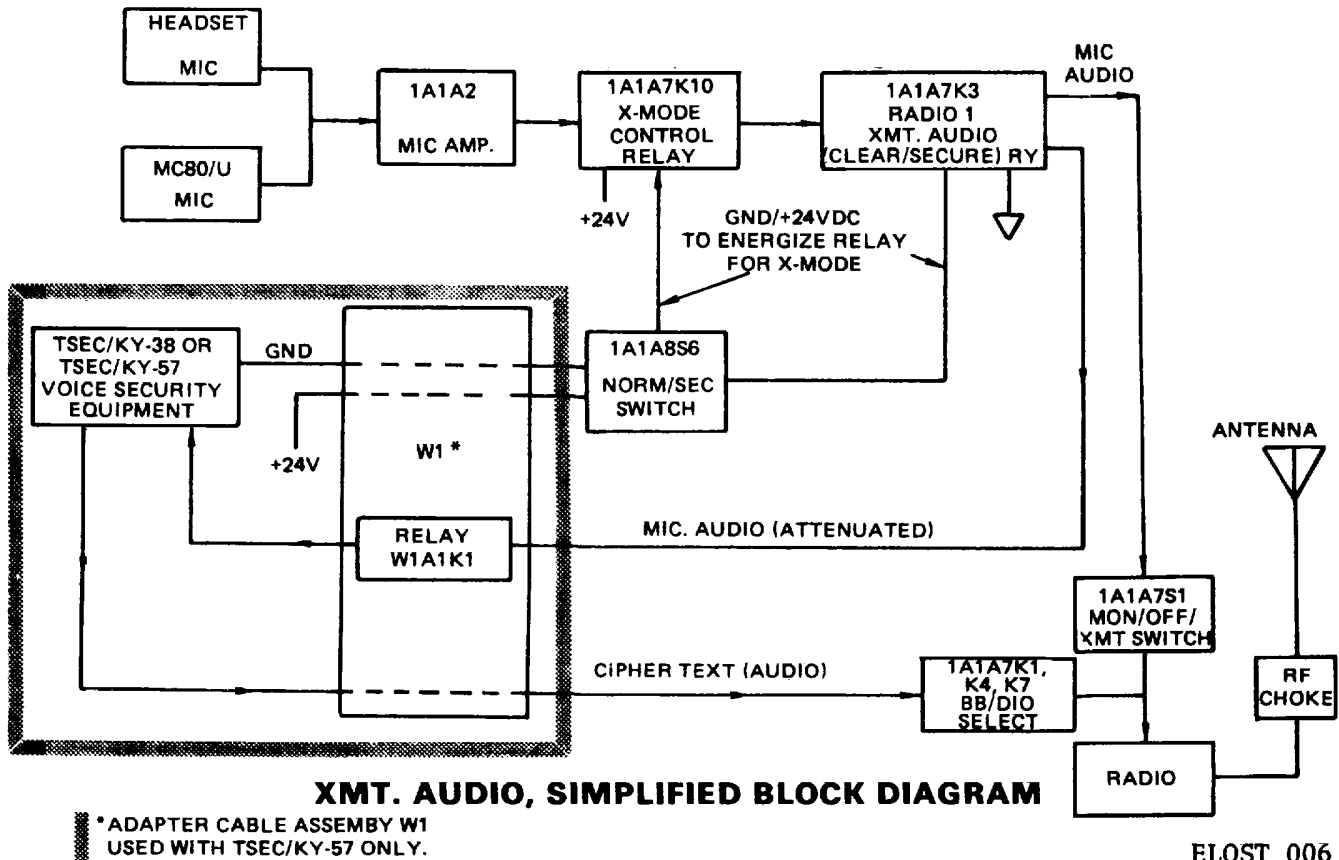

Figure 2-5. Transmit Audio, Simplified Block Diagram

modulation input or to the TSEC/KY-38 or TSEC/KY-57 (attenuated) for coding prior to application to the radio. The keying circuit is discussed separately.

2-10. Microphone Amplifier 1A1A2.

Figure 2-6 shows how the microphone amplifier interfaces with the microphone audio input. Reference is made on the figure to the proper figure for a detail flow of the output signal for both clear and X-mode operation. When supplied with an audio input from 500 Hz to 3000 Hz the output voltage is flat within -2 to +0.5 dB with reference to a 1000 Hz input. The amplifier gain can be adjusted for a gain of at least 1350. The above apply with nominal supply voltage and normal

150 ohm output load.

2-11. Receive Audio (Clear and X-Mode).

See figures 2-7, 2-17, 2-18, 2-18A. Figure 2-7 is a simplified block diagram of the receive function. All audio or cipher text from the radio is applied to the control board and to the secure voice equipment (TSEC/KY-38 or TSEC/KY-57) interface. When operating in SECURE 1, 2, or 3 relay 1A1A7K2, KS or K8 on the control board switches the audio processing line input from the secure voice equipment. After the relay the audio processing line is the same for clear or X-mode audio. The received audio (including transmit sidetones) causes the associated AUDIO indicator to light. The audio for radios not keyed will be disabled if one of the transmitters is keyed. Illumination of the AUDIO indicator lamp of clear reception is not affected.

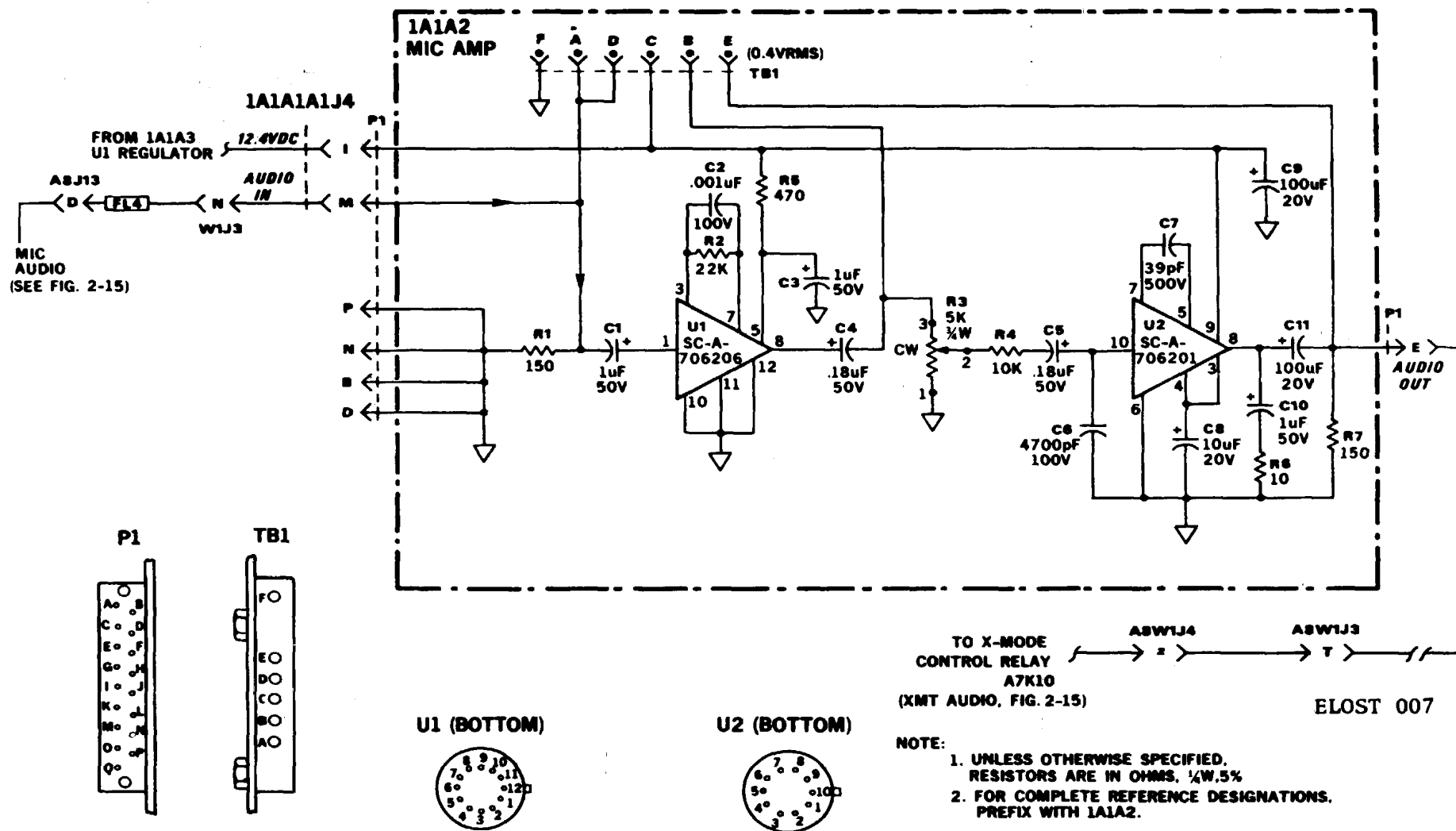

MICROPHONE AMPLIFIER BOARD 1A1A2, SCHEMATIC DIAGRAM

Figure 2-6. Microphone Amplifier 1A1A2 Schematic Diagram

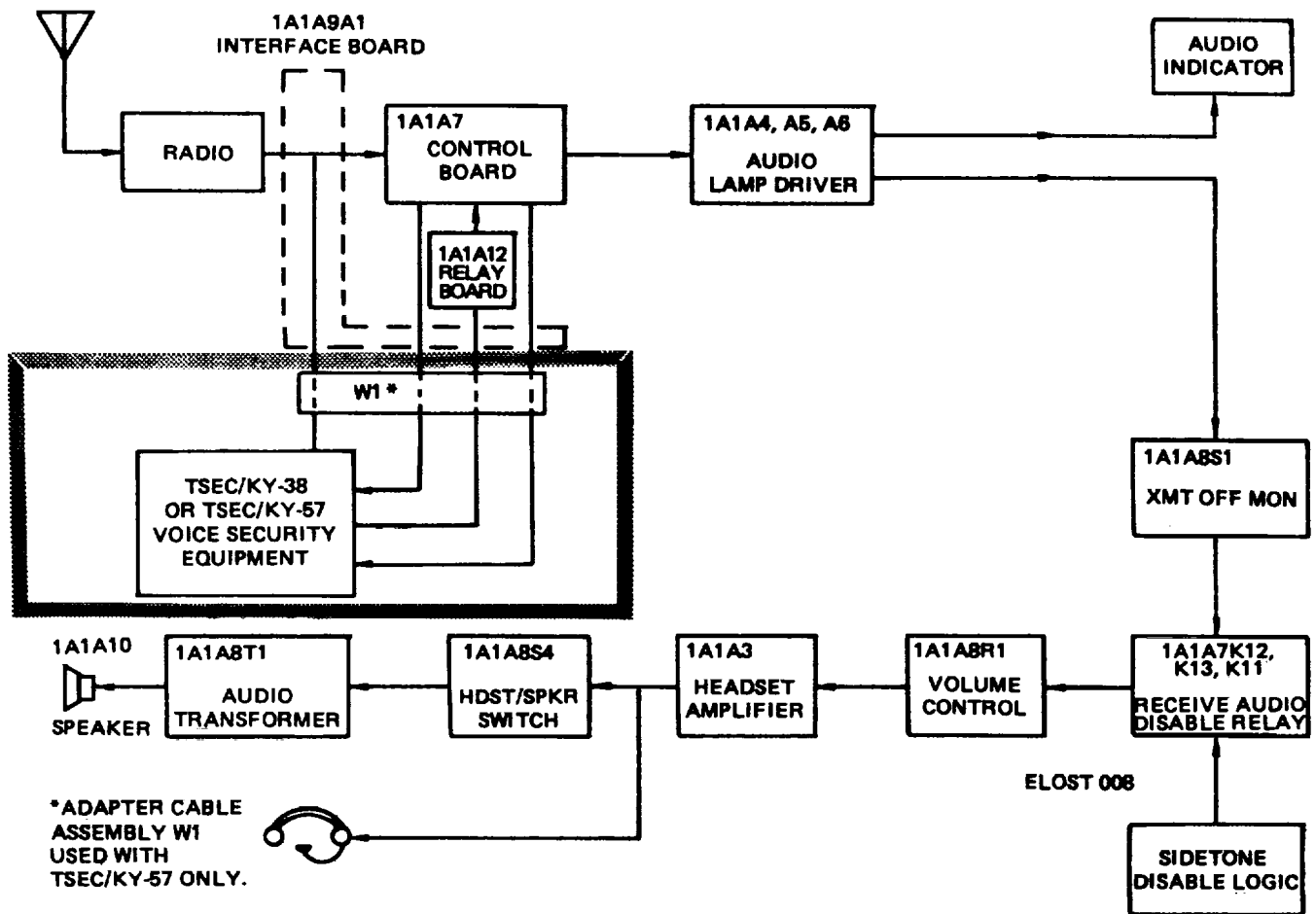

Figure 2-7. Receive Audio, Simplified Block Diagram

2-12. Secure receive audio, including the indicator lamp of radios not transmitting, is blocked by K1, 2, or 3 of secure disable relay module 1A1A12 during secure or clear transmission. The audio is volume adjusted and applied to the headset amplifier for processing to the selected output device. The audio path is discussed on the simplified signal flow diagram for this function and shown in a bold line on the functional diagram, figure 2-18, 2-18A. 2-12. Headset Amplifier 1A1A3. Figure 2-8

is the schematic diagram for this circuit. The receive signal from the volume control is applied to a standard linear voltage amplifier which boosts the gain by about 15X. The frequency response of the amplifier is flat within -2.0 to +0.5 dB between 300 Hz and 3000 Hz, with reference to performance at 1000 Hz. The output is applied to the HDST/SPKR-HDST switch for application to the selected device(s).

Change 2 2-12

2-13. Lamp Indicator Circuit Board.

Figure 2-9 shows the schematic diagram of this circuit. The applied audio is routed out through a 4.7K ohm resistor for processing. There is a lamp indicator circuit board for each radio audio path to the volume (VOL) control. The path from the VOL control to the output is common to all three, therefore the 4.7K ohms is required for isolation. The applied audio turns on Q1 which turns off amplifier Q2 to remove the clamp from CR1 and allows transistor Q3 to turn on to provide a ground (variable resistance) to energize the associated AUDIO lamp.

2-14. Keying Circuits and Audio

Disable. Figure 2-10 shows the keying circuits and audio disable function in block diagram form. When any transmitter is keyed the audio from radios not keyed (on receive mode) is disabled (AUDIO light not affected) so that the sidetone from the keyed radio can be heard from the speaker or headset. The sidetone is an indication that the transmitter is functioning and also indicates transmitter voice quality. The keyline applies

ground(s) to the side tone/audio disable logic which actuates the audio disable relays. See figure 2-19.

2-15. Control Monitor Interface.

Figures 2-11 and 2-11A show the control monitor functions associated with X-mode communications and how they interface through the secure signal cable and secure control cable to the TSEC/KY-38 (figure 2-11) or TSEC/KY-57 (figure 2-11A). The figures refer to a simplified signal flow diagram for each line wherein that function is detailed.

2-16. X-Mode Control Circuits.

Figures 2-12 and 2-12A are simplified block diagrams of the X-mode control. The purpose of this circuitry is to add additional attenuation to the audio line by relay closure, and to ground the X-mode control line to the radio, when 1A1A8S6 is on SECURE 1, SECURE 2, or SECURE 3. The microphone audio gets switched by the corresponding XMT AUDIO relay (1A1A7K3, K6, or K9), to the TSEC/KY-38 (Figure 2-12) or TSEC/KY-57 (Figure 2-12A) for coding prior to input to the radio.

Change 2 2-12A/(2-12B blank)

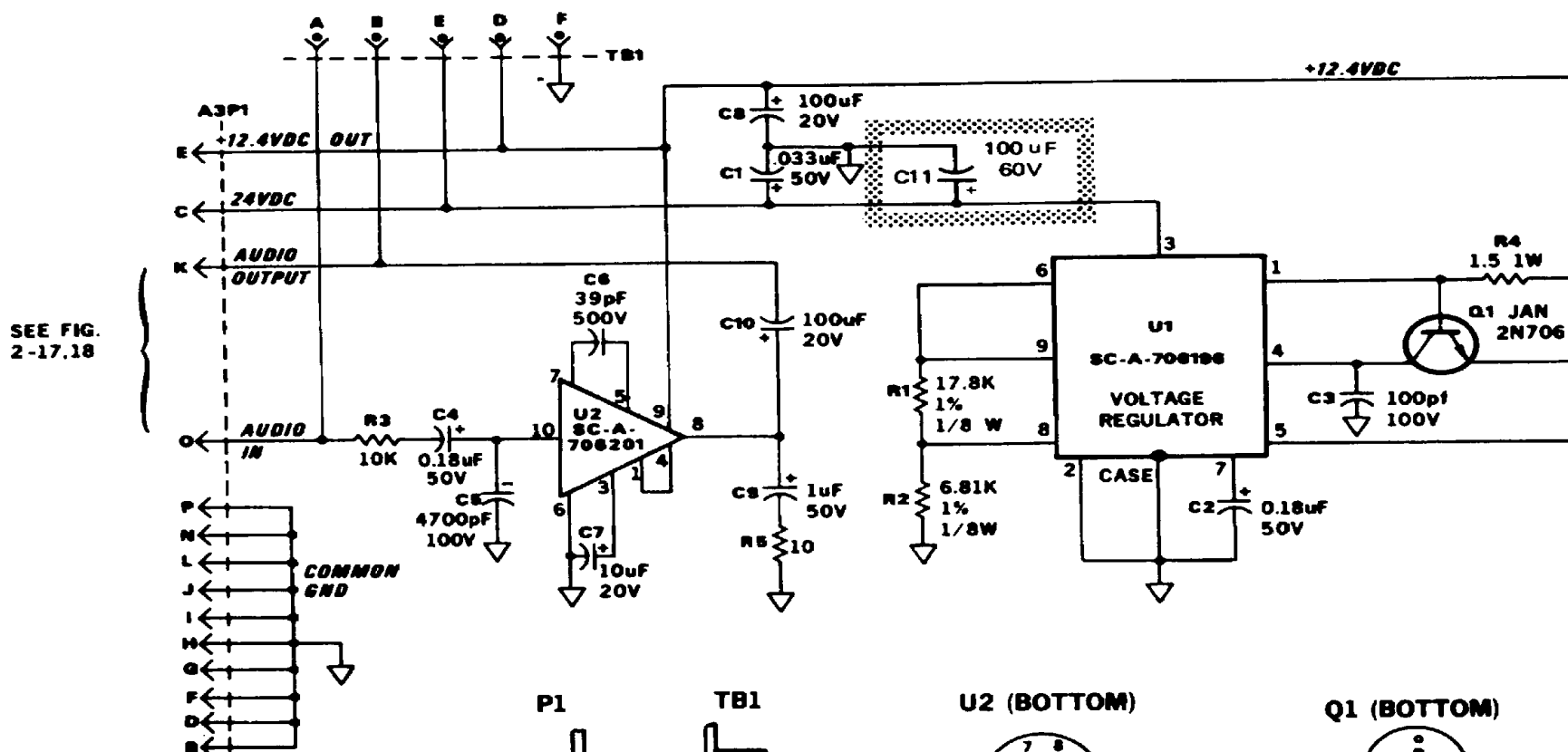

NOTES

1. UNLESS OTHERWISE SPECIFIED, ALL RESISTORS ARE IN OHMS, 1/4 WATT AND 5%
2. FOR COMPLETE REFERENCE DESIGNATIONS, PREFIX WITH 1A1A3

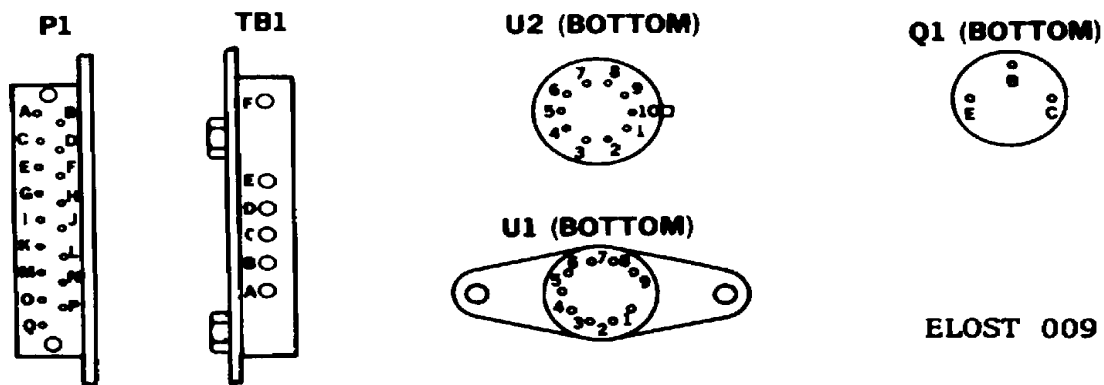

ELOST 009

HEADSET AMPLIFIER BOARD 1A1A3 SCHEMATIC DIAGRAM

Figure 2-8. Headset Amplifier Board, Schematic Diagram

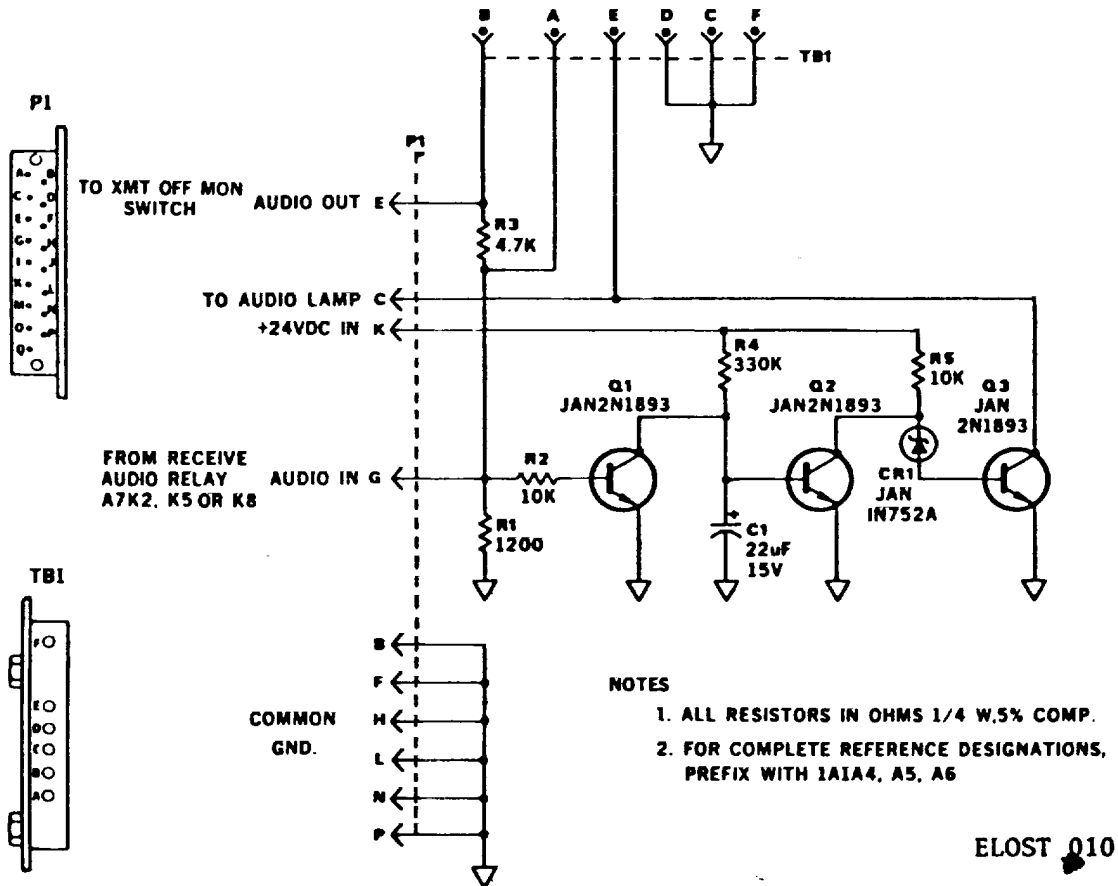

Figure 2-9. Lamp Indicator Circuit Boards 1A1A4, A5, A6, Schematic Diagram

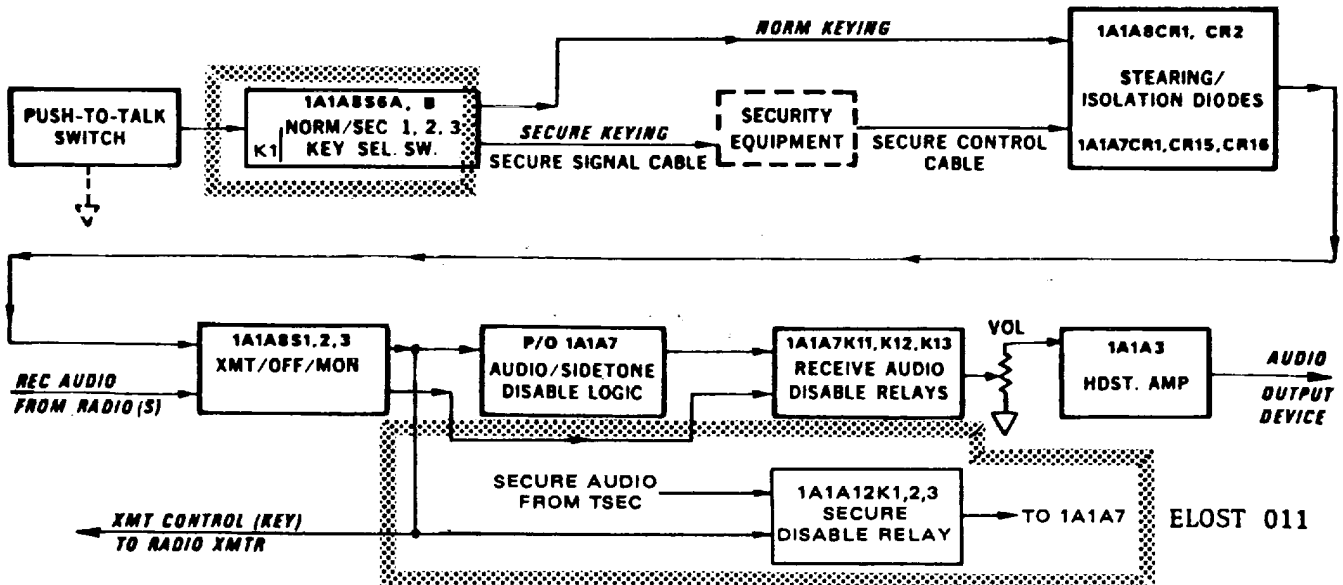

Figure 2-10. Keying Circuits and Audio Disable, Block Diagram

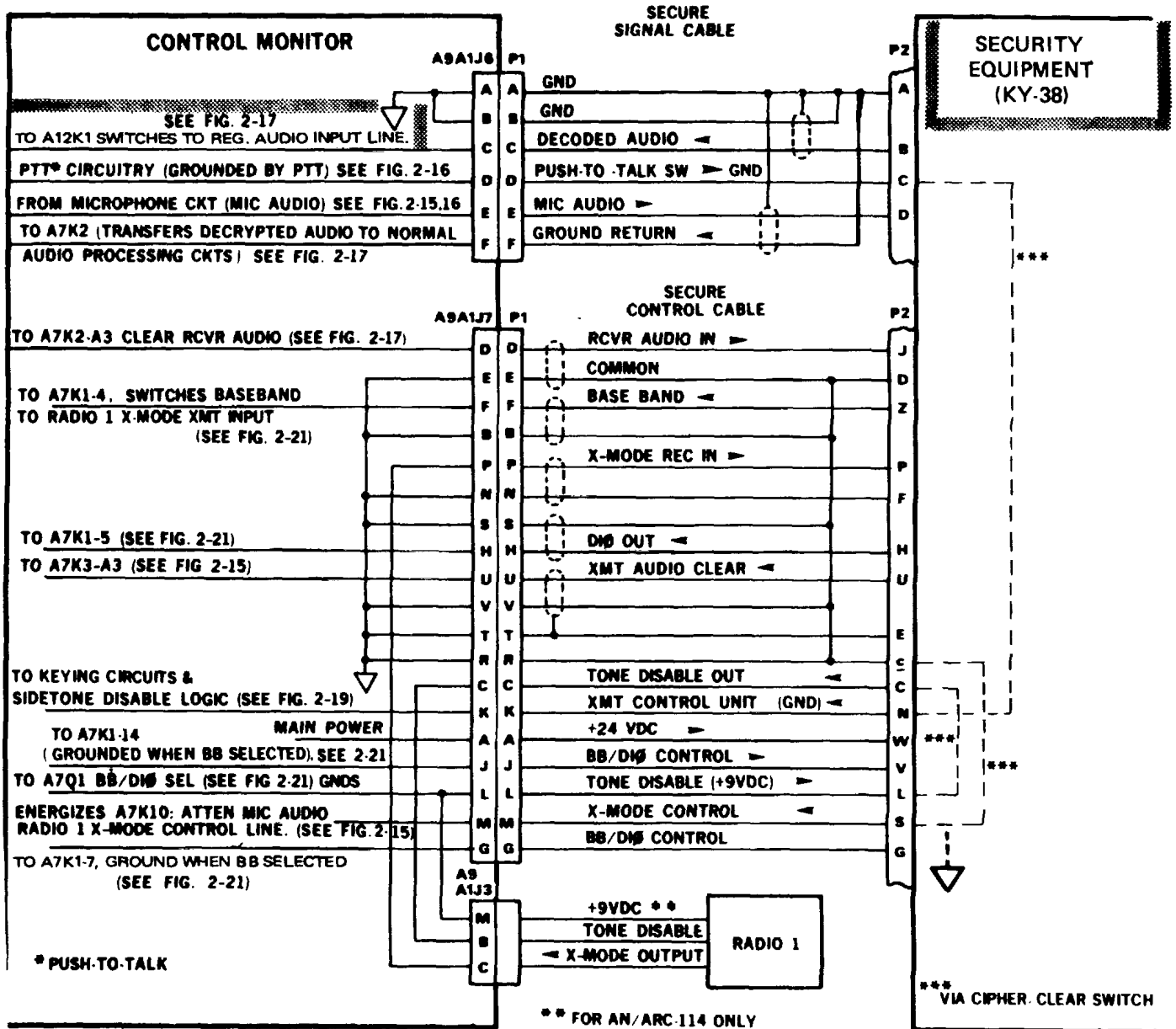

Figure 2-11. Control Monitor/TSEC/KY-38 Interface

Change 2 2-15/(2-16 blank)

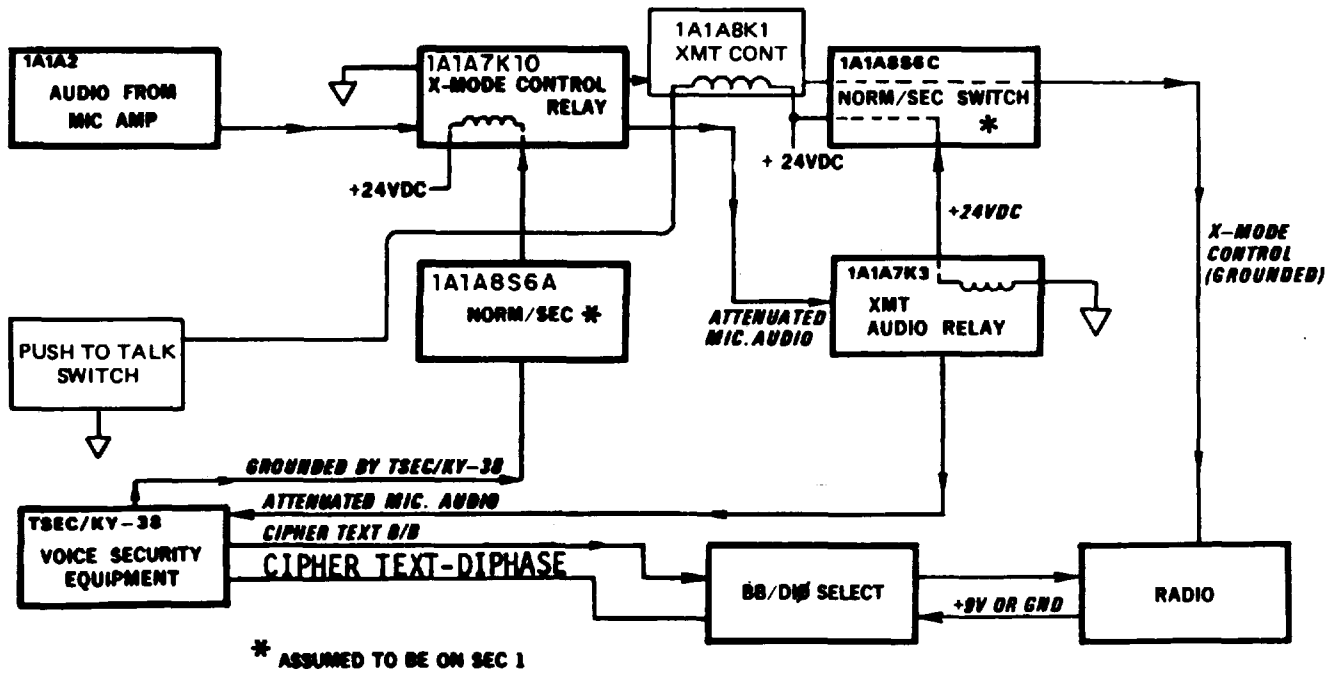
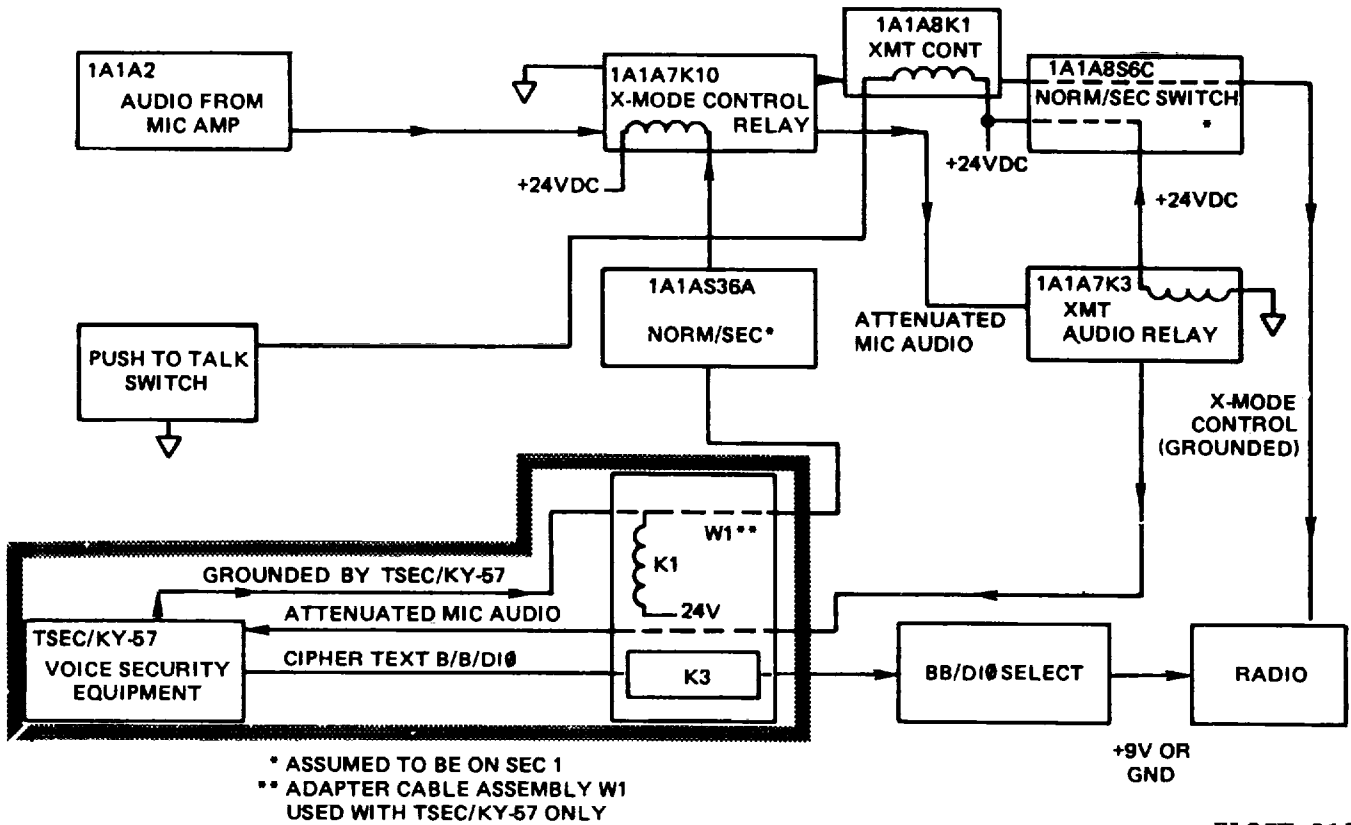

Figure 2-12. X-Mode Control Circuit Using TSEC/KY-38 Security Equipment

2-17. Baseband Diphas Select.. Figures 2-13 and 2-13A outline the basics of baseband or diphas code select. When the AN/ARC-114A is installed in any radio position, the tone disable out- put turns on a transistor (1A1A7Q1, Q2 or Q3) which energizes a relay (1A7K1, K4, K7). The relay, when energized, latches and makes the necessary con- nections to select baseband coding. Connections from the XMT MODE switch 1A1A8S6 ground the X-mode control line to the radio via 1A1A8K1 and route the key-line through the TSEC/KY-38 (Figure 2-13) or TSEC/KY-57 (Figure 2-13A). Also on any SECURE position, a transmit audio relay (1A1A7K3, K6 or K9) and 1A1A7K10 energize to switch the microphone audio from direct radio input to the TSEC/KY-38

or TSEC/KY-57 and add 22K ohms of attenuation to the audio input line.

2-18. Wind Detector. Figure 2-14 shows this circuit in simplified block form. The output from the dc generator and the synchro transmitter of the ML-653/TSQ-97 are applied through cable W402, the RF choke, and cable W401 to the control monitor where the signals are routed to the respective WIND DIRECTION or WIND SPEED indicator meter. The synchro transmitter in the detector and the synchro receiver in the indicator both receive 26 volts ac rotor reference voltage when PUSH TO OPERATE switch is pressed (see figure 2-4).



ELOST 013

Figure 2-12A. X-Mode Control Circuit Using TSEC/KY-57 Security Equipment

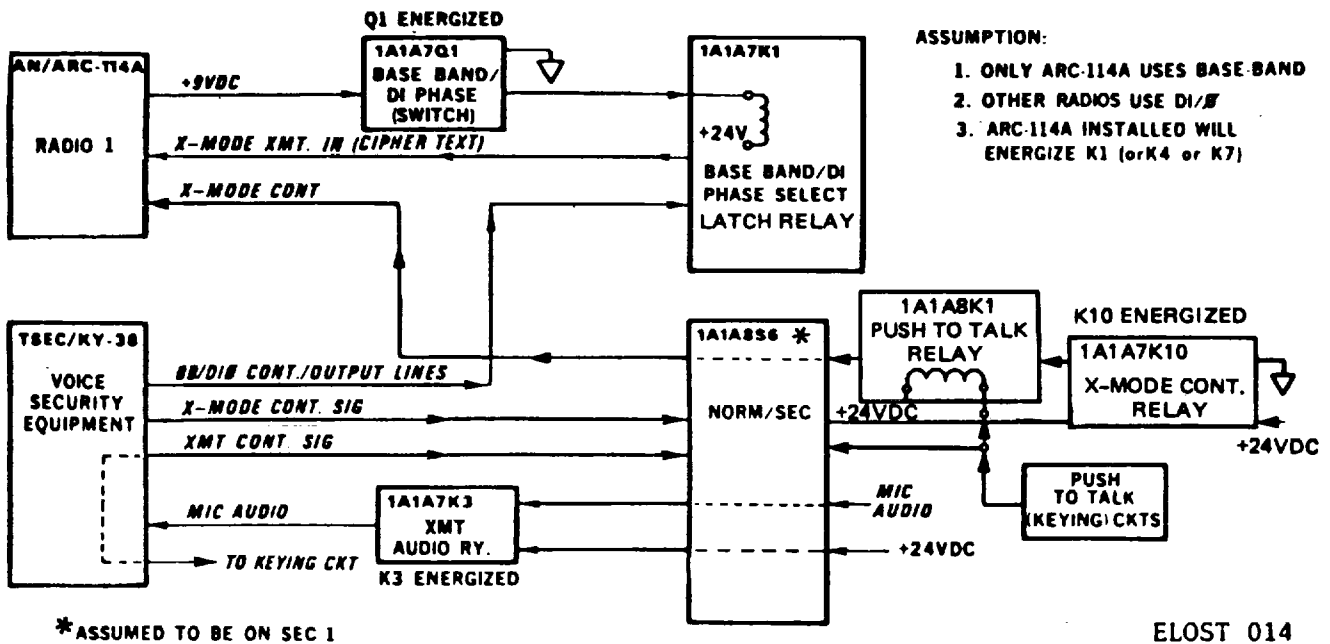

ELOST 014

Figure 2-13. Base Band/DI Phase Select Using TSEC/KY-38 Security Equipment, Simplified Block Diagram

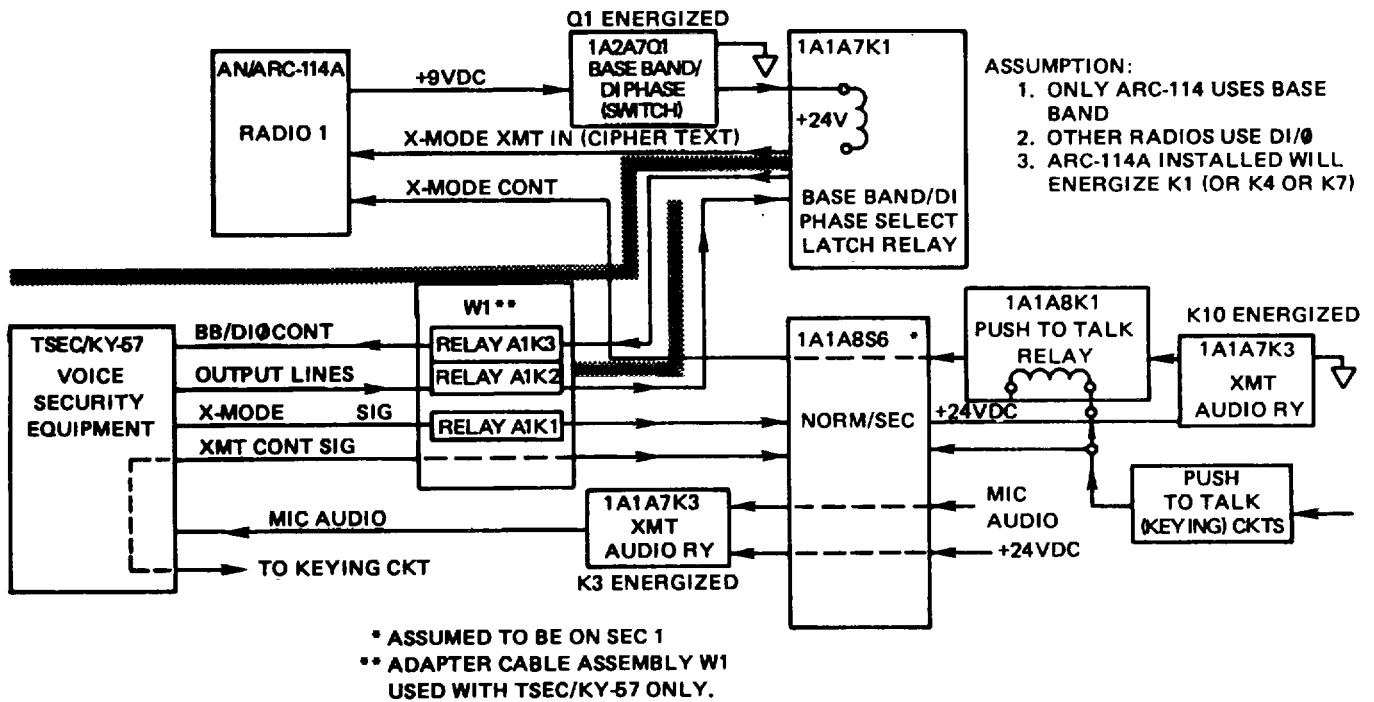

Figure 2-13A. Base Band/DI Phase Select Using TSEC/KY-57 Security Equipment, Simplified Block Diagram

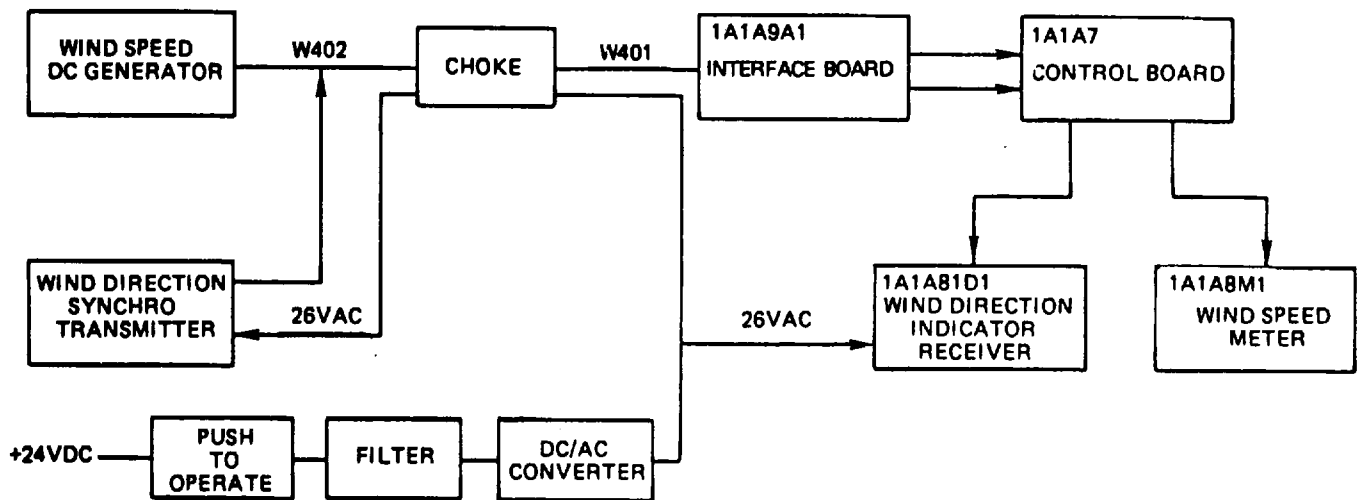

Figure 2-14. Wind Detector Circuits, Simplified Block Diagram

ELOST 015

Section III. CIRCUIT ANALYSIS

NOTE

The following descriptions address RADIO 1 position, because signal flow paths for all radios are similar. The only difference is connector pin assignments and component reference designators. See figure FO-2 for composite schematic diagram.

2-19. Transmit Clear Audio and Control (Keying).

Figure 2-15 shows the simplified signal flow for transmit audio (radio 1 circuit shown). Clear audio transmission requires two signals. One is the transmit audio signal and the other is the transmit control (keying) signal, see figure 2-19.

a. Transmit Audio. The transmit audio signal originates at the microphone which converts the human voice into an electrical signal. This signal is applied to the microphone amplifier fA1A2 board through connectors J13 and A8W1 J3. The output of the microphone amplifier board is applied to radio I through normally closed contacts of relay K3, and through closed contacts of XMT OFF MON switch S1 (XMT position). Sidetone is generated in the radio and is applied to the receive circuits in the same manner as a received audio signal.

b. Transmit Key. (See figure 2-19.) The transmit control signal is activated when the push-to-talk switch on the microphone is closed providing a ground through connector J13 for K1 and in turn for wafers A and B of TRANSMIT MODE switch S6. When switch S6 is in the NORM position, the keying signals are applied to radio

1, 2, 3 XMT OFF MON switches, S1, S2, S3. When switch S1 is in XMT, the keying signal (chassis ground) is connected to radio 1 transmit control through diode CR2. Radio 1 transmit control signal keys the radio transmitter to provide a modulated output signal. Diode CR2 prevents transients generated within the radio set from keying the security equipment. The keying signal also activates the audio disable logic to turn off the audio from radios not keyed.

2-20. Transmit X-Mode Signal (Fig. 2-16, 2-16A, 2-20, 2-20A, 2-21, 2-21A).

Relay A7K1 is controlled by the 9 volt tone disable signal from the security equipment. In the de-energized state, +24 vdc is applied to the security equipment baseband/diphase (BB/DI0) control, and the security equipment diphase out is applied to the radio X-mode transmit in. With A7K1 in the energized state, a ground is applied to the security equipment BB/DI0 control and diphase out, and the security equipment baseband is connected to the radio X-mode transmit in. When TRANSMIT MODE switch S6 is in the SECURE RADIO 1 position, the security equipment X-mode control signal is connected to the coil of relay K10 on the control board through wafer A of switch S6. A ground will energize relay K10 removing a short across R21, part of the audio out "L" resistor pad R20/R21, and applying a ground via the XMT CONT relay to the radio X-mode control signal. The grounded X-mode control signal is connected to radio 1 X-mode control through wafer C of switch S6. The +24 vdc is applied to relay K3 through wafer C of switch S6. When the relay energizes, the attenuated audio signal is connected to the security equipment microphone audio in. The keying circuit is shown on figure 2-19.

Change 2 2-21

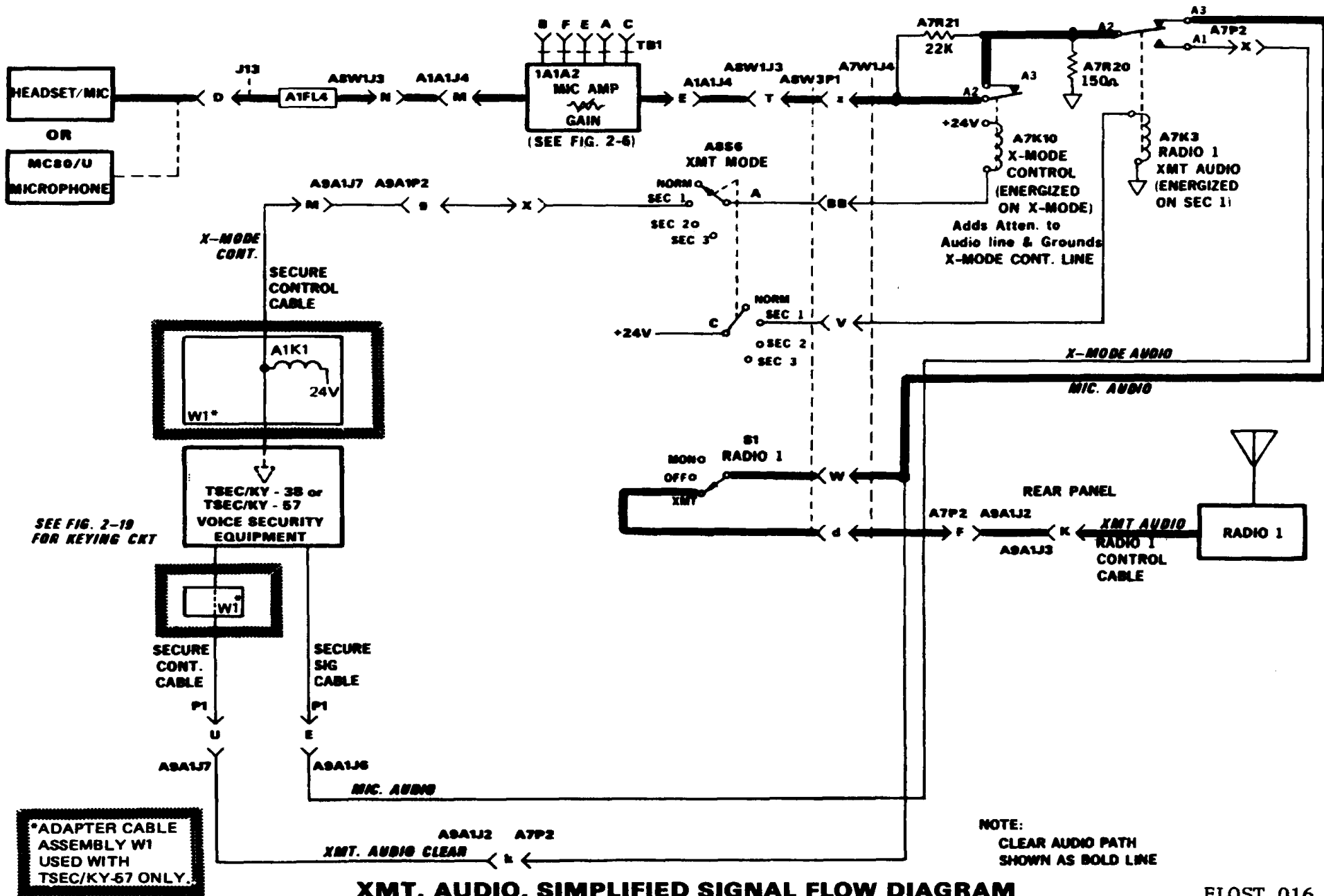

XMT. AUDIO, SIMPLIFIED SIGNAL FLOW DIAGRAM

ELOST 016

Figure 2-15. Transmit Audio, Simplified Signal Flow Diagram 2-22

TRANSMIT MODE SIMPLIFIED FUNCTIONAL DIAGRAM

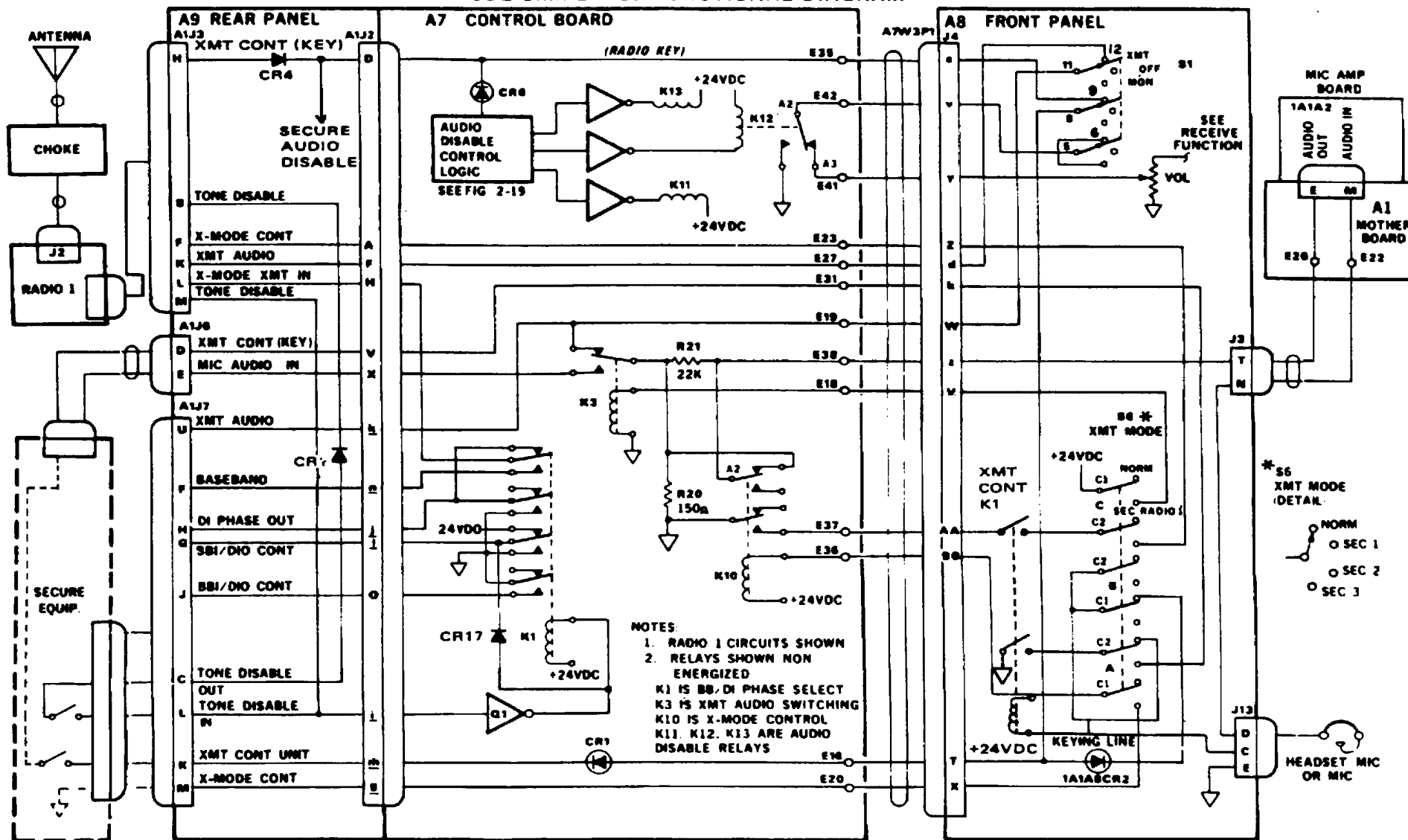

ELOST 017

Figure 2-16. Transmit Audio (X-Mode) Using TSEC/KY-38 Security Equipment Simplified Functional Diagram

Change 2 2-22A(2-22B blank)

2-21. Receive Clear Audio (Fig. 2-17, 2-18, 2-18A).

Signals received by the radio are applied to connector 1A1A9A1J3 (Radio 1), J4 (Radio 2) or J5 (Radio 3) on the rear panel. The audio signal is applied to a resistor L-pad (X-mode only) on control board 1A1A7 to eliminate the need for volume adjustment when changing from clear to X-mode reception. The output of the L-pad is connected to normally closed contacts of relay 1A1A7K2. The received clear audio is also applied (as shown) to the receive audio input of the TSEC/KY-38 or TSEC/KY-57 so that when the speech security equipment is connected (relay A7K2 energized) clear audio can still be processed. The audio is routed to the lamp indicator board to activate a transistor circuit which causes the AUDIO indicator to light to indicate the presence of received audio (or sidetone). The signal is then applied through the XMT-OFF-MON switch which determines signal routing within the control monitor. With the switch in OFF position the audio line is open. With the XMT-OFF-MON switch in XMT or MON, the audio is applied through normally closed contacts of audio disable relay 1A1A7K12. If any radio is transmitting, the audio disable relays for the radios not keyed will energize and ground their audio path, so that only the audio sidetone from the keyed radio is audible. From the audio apart and a rotor. Stators 1, 2 and disable relay, the signal is applied to the VOL control, then to the headset amplifier board 1A1A3 for conditioning prior to final output. Figures 2-18 and 2-18A show the clear audio path as a bold circuit line.

2-22. Receive Secure Signal. (See figures 2-18, 2-18A.) Radio signals received by the radio are applied to connector J3 on the rear panel of the AN/ TSQ-97.

However, when security equipment is connected, relay K2 is energized and the audio signal is routed through the security equipment where it is decoded. The decoded audio signal via secure audio disable circuit, 1A1A12, routed in the same manner as a clear audio signal except the keying line also opens audio lines at the clear connectors. Therefore, when the control monitor is in a secure position, the other audios are opened. In normal position a grounded key line opens the other two secure audios. Any two keying lines grounded in normal position shall open all secure audio lines. Output from the monitor shall be measured with a clear audio input of 2VRMS.

2-23. Wind Speed and Direction Circuits.

a. *Wind Direction Circuit.* (See figure 2-22.) The wind direction transmitter is contained in the fixed body of Wind Direction and Speed Detector ML-653/TSQ-97, which is mounted in the front panel (WIND DIRECTION indicator). The wind direction circuit is a torque synchro system consisting of a transmitter and a motor or receiver. A schematic diagram of the synchro system is provided in figure 2-22. Synchro transmitters and receivers consist of three stator windings electrically spaced 120° apart and a rotor. Stators 1, 2 and 3 of the transmitter are respectively connected to stators 1, 2, and 3, of the receivers. The transmitter rotor and receiver rotor are connected in phase to a 400 Hz 26 volt signal. As long as the rotors are in the same position with respect to the stators, no current will flow between the windings because the voltage is balanced in the windings. When the transmitter rotor is rotated by the wind action on the vane, a signal is generated in the

stator by electromagnetic coupling. The receiver receives the signal and converts it into an output torque. The torque will cause the receiver rotor to rotate until it is electrically aligned with the transmitter's rotor. The PUSH TO OPERATE power switch S7 must be pressed before the wind detection circuits will operate. When switch S7 is pressed, ac power is supplied for the synchros and dc power is supplied to the power on light and the indicators eyebrow lights.

b. Wind Speed Circuits. The wind speed circuit consists of a wind driven dc generator connected to a dc microammeter. The generator is contained in the rotatable body of Wind Direction and Speed Detector ML- 653/TSQ-97, which is mounted on the antenna mast. The microammeter is mounted on the front panel. The micrommeter is scaled to indicate in knots. A signal flow diagram is presented in figure 2-22. A resistor network consisting of R10, R11, and R12 is provided for calibration. The network is located on the

control board 1A1A7. The impeller of the generator turns in proportion to the wind speed acting on it at any given time. Only the adjustments on 1A1A7 require adjustment after the circuit board has been repaired or changed, and when the WIND SPEED meter is changed.

2-24. MK-2225/TSQ-97 Installation Kit Power Distribution Panel. (See figure 2-23.) The MK-2225/TSQ-97 installation kit is used in conjunction with TSEC/ KY-57 security equipment when secure voice communications are required. The installation kit is not required when TSEC/KY-38 equipment is used. The power distribution panel, part of the installation kit, provides power to the TSEC/KY-57 equipment through connectors J1, J2, and J3, and can provide operating power to the AN/TSQ-97 facility through PWR OUT connector J4. The panel receives power, either from a battery or a vehicular source, through PWR IN connector J4.

Change 2 2-26

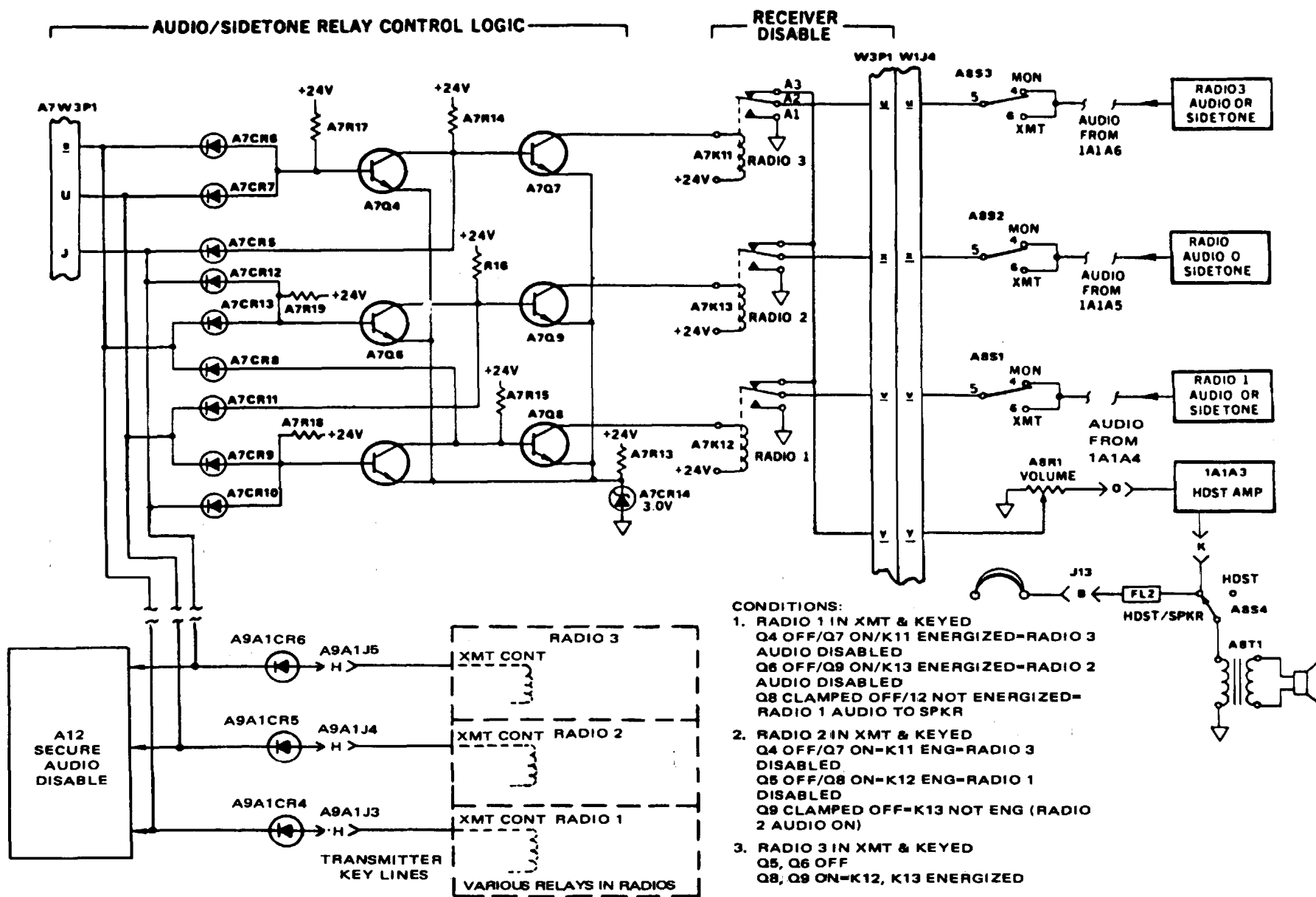
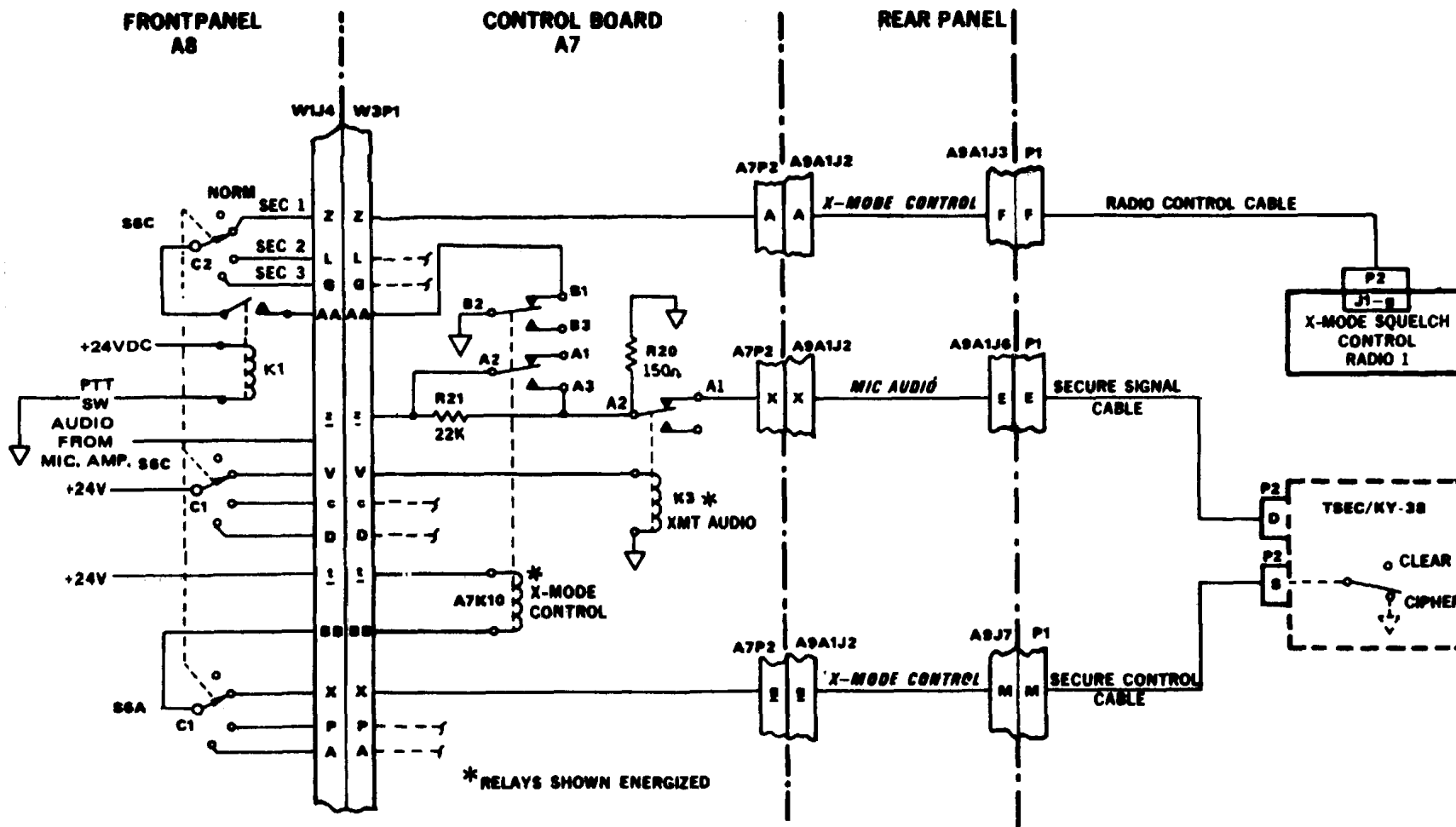

Figure 2-19. Keying Circuits and Audio Disable (Sheet 2 of 2)



X-MODE CONTROL CIRCUITS SIMPLIFIED SIGNAL FLOW DIAGRAM

ELOST 022

Figure 2-20. X-Mode Control Circuits With TSEC/KY-38 Security Equipment, Simplified Signal Flow Diagram

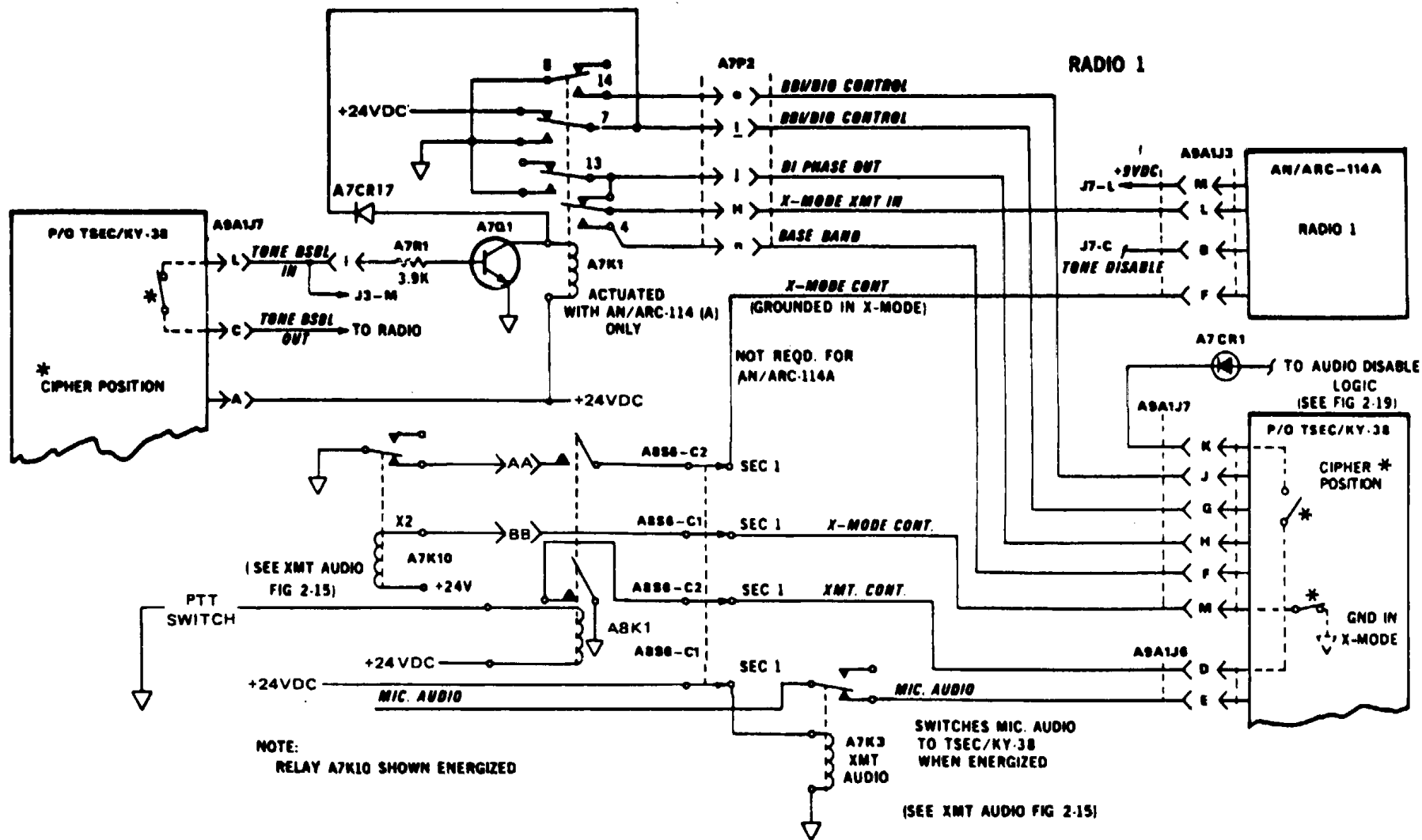

BASE-BAND/DI-PHASE SELECT SIMPLIFIED SIGNAL FLOW DIAGRAM.

Figure 2-21. Base Band/DI Phase Select, Using TSEC/KY-38 Security Equipment, Simplified Signal Flow Diagram

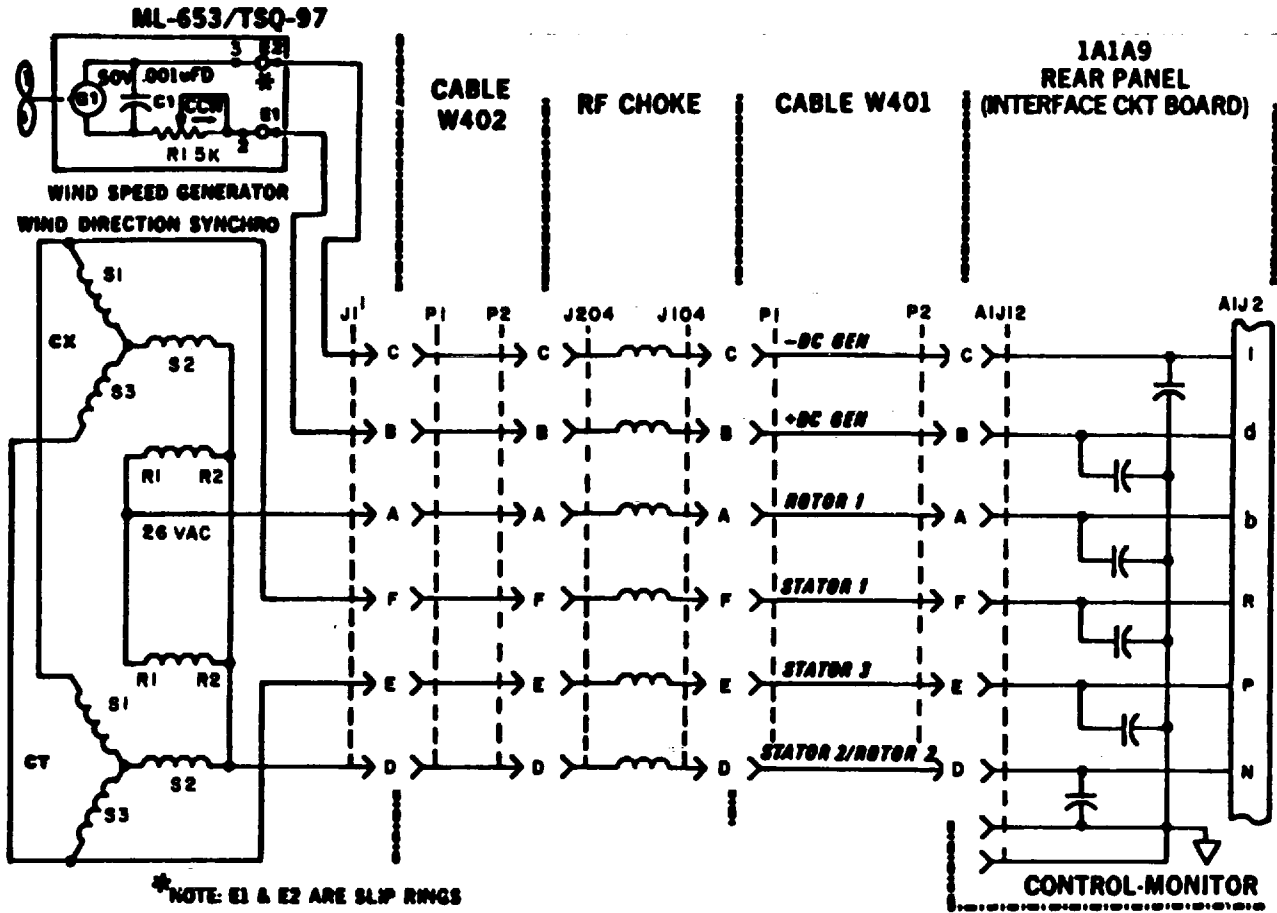

TO 1A1A7P2
 CONTROL BOARD
 (SHEET 2)

ELOST 024

Figure 2-22. Wind Detector Circuit, Simplified Signal Flow Diagram (Sheet 1 of 2)

Change 2 2-41

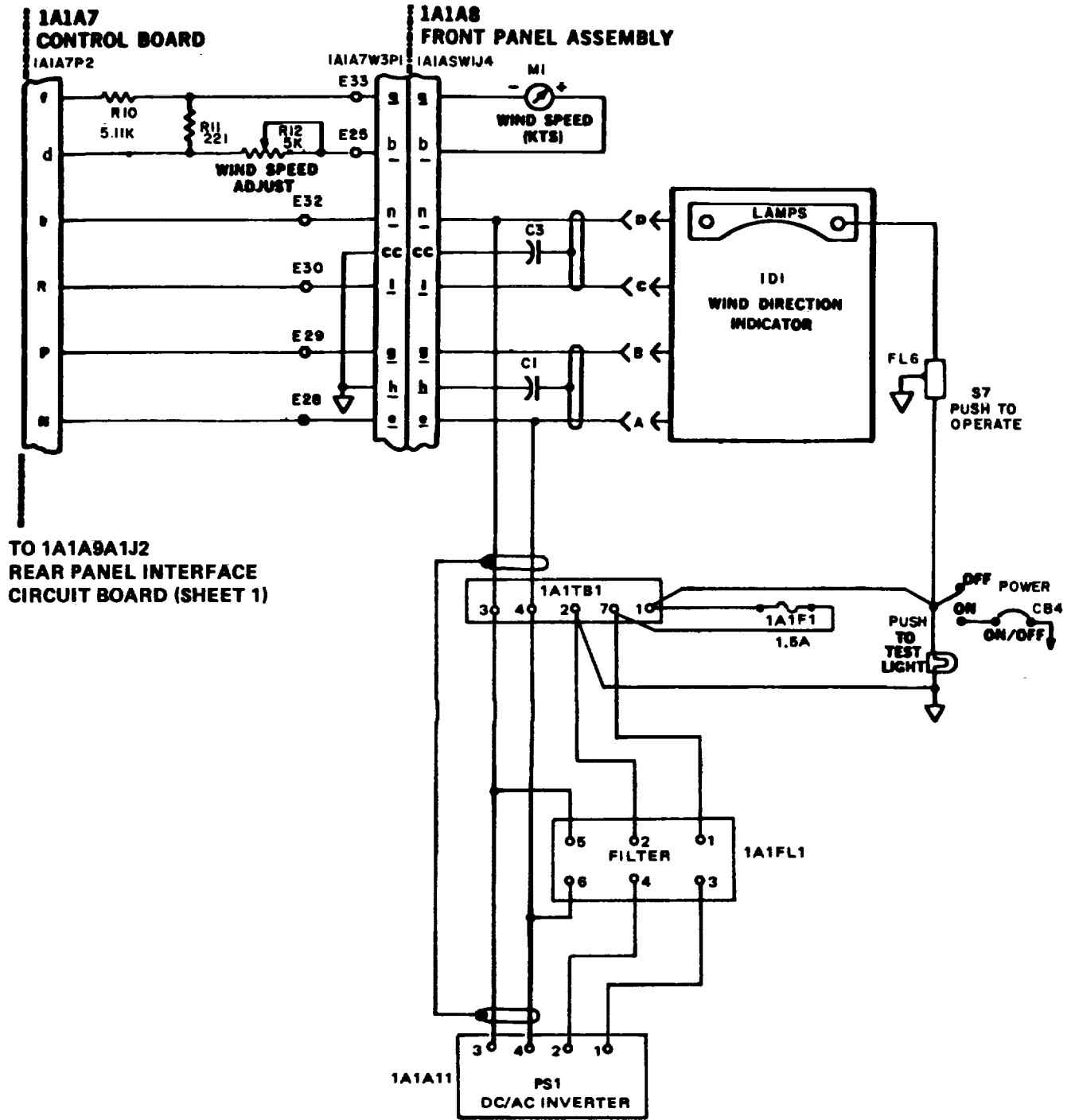

ELOST 029

Figure 2-22. Wind Detector Circuit, Simplified Signal Flow Diagram (Sheet 2 of 2)

Change 2 2-42

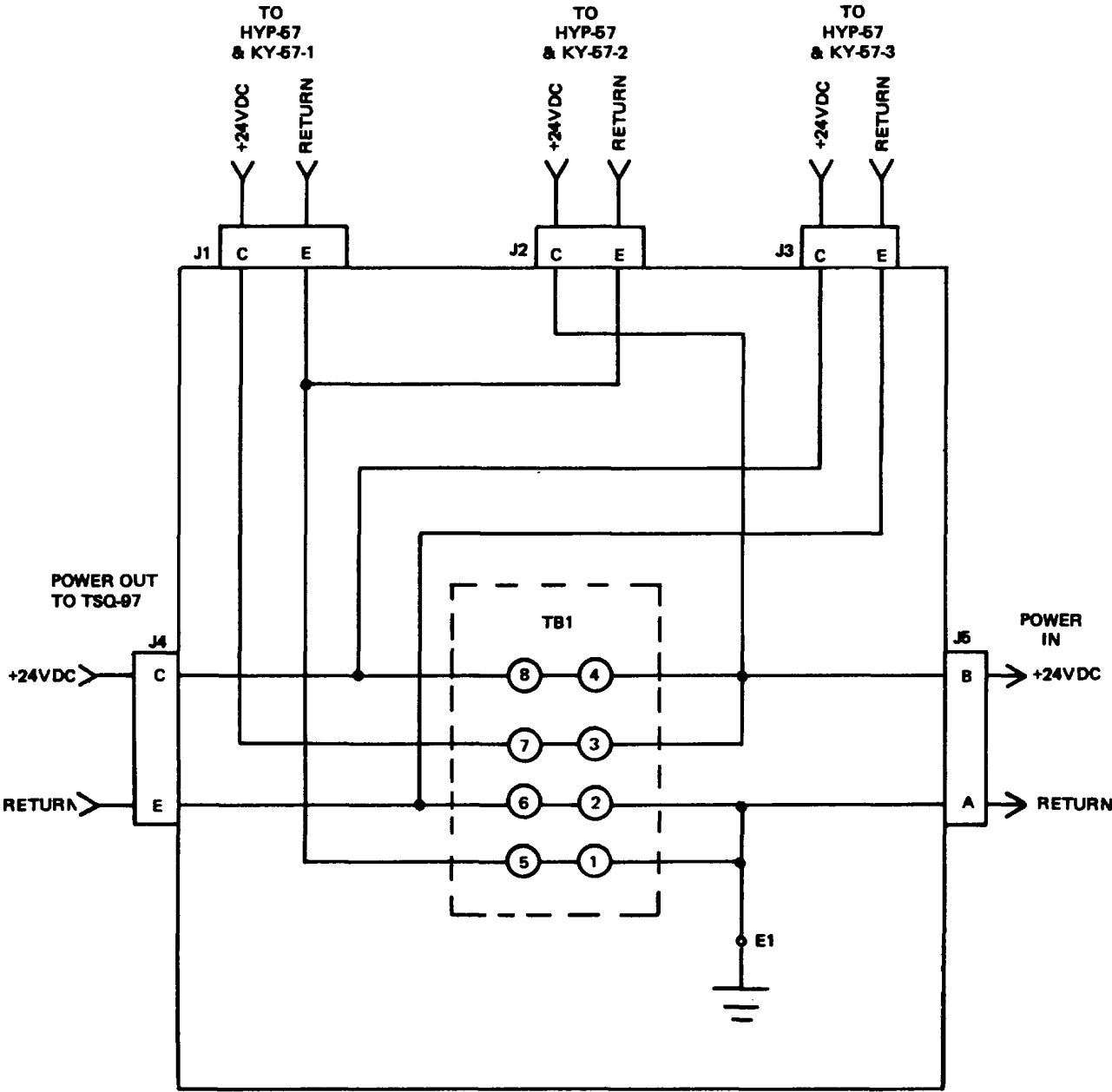

Figure 2-23. MK-2225/TSQ-97 Installation Kit Power Distribution Panel, Schematic Diagram

Change 2 2-43/(2-44 blank)

CHAPTER 3

DIRECT SUPPORT MAINTENANCE INSTRUCTIONS

Section I. GENERAL INSTRUCTIONS

3-1. Scope. Direct support maintenance supplements operator and organizational maintenance. All maintenance authorized for lower levels shall also be done at direct support as needed. Direct support personnel shall interpret failure symptoms and isolate the cause to a replaceable or repairable assembly and replace or repair as necessary. This includes checking and repairing system cables, changing antennas, printed circuit boards and some front panel, rear panel and interior parts and assemblies. Procedures are included for performance tests that exercise control monitor circuitry for the associated functions. Schematic diagrams are referenced for making point-to-point ohmmeter checks of system cables, the choke and the interface board. If a repaired circuit or changed circuit board requires adjustment for proper operation, those alignment procedures are included. Printed circuit boards are repairable only at depot level.

3-2. Organization of Troubleshooting Procedures. Troubleshooting at direct support should be done in a logical sequence to isolate a failure cause to system cables (see table 3-2), or the control monitor A1, printed circuit card A2 (Microphone Amplifier), A3 (Headset Amplifier), A4-A6 (Lamp Indicator control boards) and other easily replaced control monitor parts, including the WIND DIRECTION indicator, WIND SPEED meter, altimeter, BATTERY meter and the time clock. Follow steps *a* - *e* below as applicable to troubleshoot the facility.

a. Visual Inspection. Inspect for obvious damage, cables not properly connected, switches not in proper position for expected results. Unfasten eight captive rear panel fasteners. Lower rear panel and inspect interior to see that all connectors are secure and nothing is missing. Figure 3-1 shows the interior view with rear panel A9 lowered.

b. Refer to the troubleshooting chart, table 3-5, to see if a similar failure symptom is listed.

c. Power Distribution. If the symptoms appear to be a failure within the power distribution network, refer to paragraph 3-5 and figure 2-4 and make the continuity measurements noted. If all continuity measurements are as listed, make the voltage measurements listed in table 3-4.

d. Voltage and Resistance Measurements. To prove the integrity of circuitry and switching used for various functional modes, perform the appropriate operational tests for the functions as defined in 3-6.c.

e. Test Points. Test points for measuring circuit applied +24 vdc and various circuit functions are contained on modules A2 - A6. (See figures 2-6, 2-8, 2-9.)

f. System Cables/Continuity Tests. Perform continuity tests as directed in paragraph 3-4 and table 3-2.

3-3. Test Equipment, Tools and Accessories.

Type, common name and associated National Stock Number (NSN) or technical manual for equipment required to test, troubleshoot and adjust the facility are listed in table 3-1. Required tools are contained in Electronic Equipment Tool Kits TK- 100/G and TK-105/G.

3-4. System Cabling. Table 3-2 lists system cables and lists the schematic diagram for reference when making continuity measurements to locate a malfunction within the cable wiring. End-to-end

measurement on each line is considered acceptable if the resistance is less than 1 ohm. For checks from shield to not-connected pin and between not-connected pins on the same connector must indicate infinite resistance.

3-5. Power Distribution Circuit Measurements.

a. *Ohmmeter Checks.* Power distribution network ohmmeter checks listed in table 3-3, will locate opens

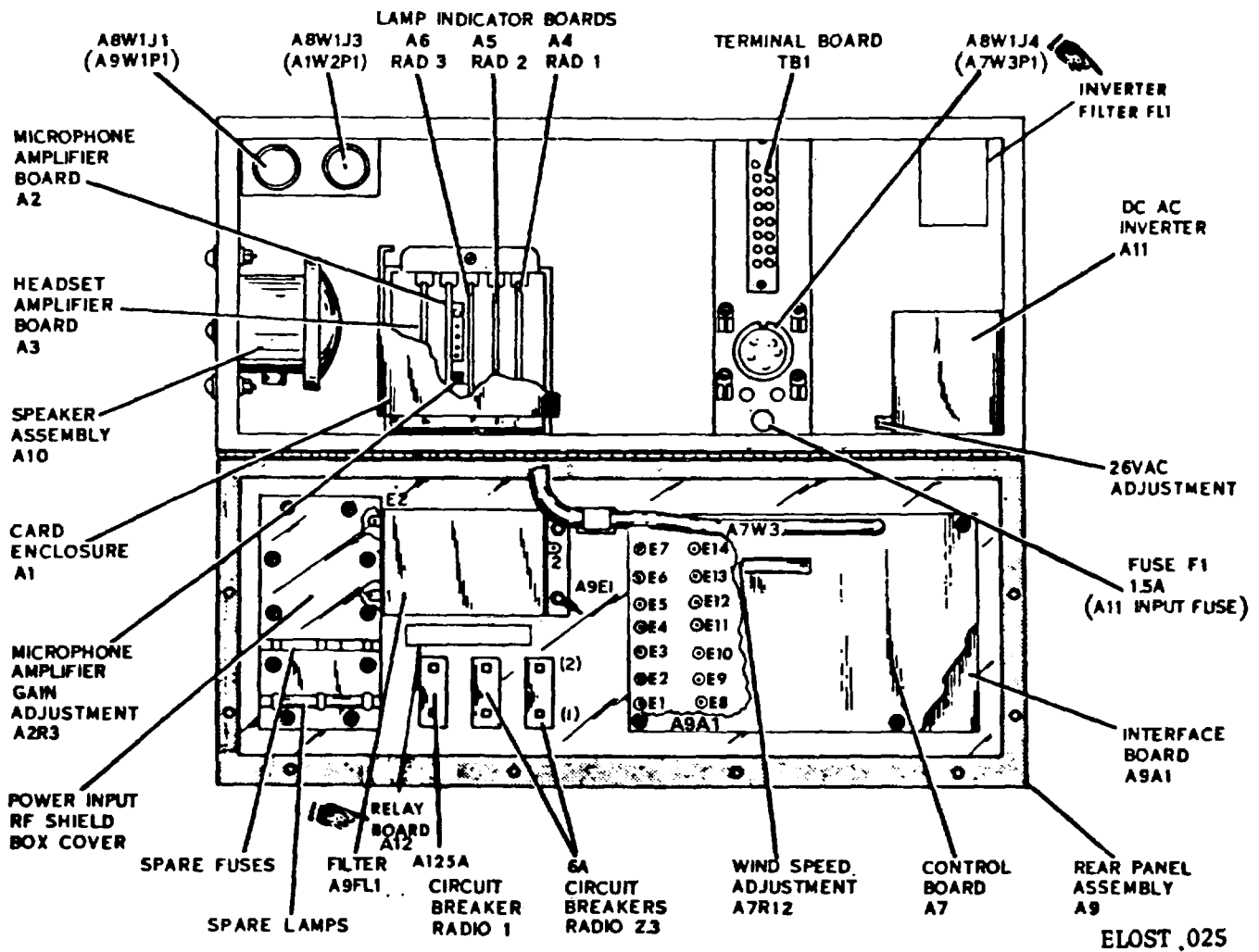

Figure 3-1. Control-Monitor C-9921/TSQ-97 (Unit 1A1) Rear Interior View (Front Panel, A8, Mounted Parts Not Shown)

Table 3-1. Test Equipment, and Tools

Type	NSN or Technical Manual	Common Name
TS-421/U Audio Oscillator	6625-00-669-0228 TM 11-6625-355-12	Signal Generator
AN/USM-223 Multimeter	6625-00-999-7465 TM 11-6625-654-14	Multimeter
AN/GSM-64 Digital Voltmeter	TM 11-6625-444-15	Digital
ME-30(*)/U, Voltmeter, Electronic	6625-00-643-1670 TM 11-6625-320-12	Voltmeter
TK-100/G Electronic Equipment Tool Kit	5180-00-605-0079	Tool Kit
TK-105/G Electronic Equipment Tool Kit	5180-00-610-8177	Tool Kit
Wattmeter	6625-00-649-5070	Thru-line meter
Oscilloscope AN/USM-281		Scope
Power Supply 32 vdc min.		DC Supply
Power Supply 26 Vac 400 Hz		DC Supply

Table 3-2. Cable Schematic Diagrams

Cable	Use	Schematic Fig. No.
Radio Control	Connects radio to Control Monitor	FO-3 A
Antenna (coaxial) Cables	Antennae to rf choke, rf choke to radio	NA (Single line)
Wind Direction & Speed: W401	Connects between rf choke and Control Monitor	FO-3 B
W402	Connects between Wind Detector and rf choke	FO-3 C

Table 3-2. Cable Schematic Diagrams (Cont)

Cable	Use	Schematic Fig. No.
Secure Control	Connects between TSEC/KY-38 and Control Monitor or between TSEC/KY-57 Adapter Cable and Control Monitor	FO-3 D
Secure Signal	Connects between TSEC/KY-38 or TSEC/KY-57 and Control Monitor	FO-3 E
Adapter Cable W1 (Part of MK 2225/TSQ-97 Installation Kit)	Connects between TSEC/KY-57 and Secure Control Cable	FO-3 H
Power: W101 (Part of MK 2225/TSQ-97 Installation Kit)	Connects between TSEC/KY-57 and Power Distribution Panel of MK-2225/TSQ-97 Installation Kit	FO-3 I
W701 (Part of	Connects between Battery Terminal Adapter MX-4430/PRC-47 (on BB-451/U) and POWER IN Connector J1 on Control Monitor	FO-3 F
W701 (Part of MK-2225/TSQ-97 Installation Kit)	Connects between Battery Terminal Adapter MX-4430/PRC-47 (on BB-451/U) and POWER IN Connector J5 on MK-225/TSQ-97 Installation Kit Power Distribution Panel	FO-3 F
W702 and Alternate 50 Foot Power Cable	Connects to Vehicular Power Source and Control Monitor POWER IN Connector. When using MK-2225/TSQ-97 Installation Kit connects to Vehicular Power Source and POWER IN Connector on MK-2225/TSQ-97 Installation Kit Power Distribution Panel.	FO-3 G

Table 3-3. Power Distribution Network Resistance Measurements

From	To	Resistance		Condition	Remarks
		Inf.	Short		
J1-A	chassis ground		x		
J1-A	J2-A		x		
J1-B	chassis ground	x			
J1-B	J2-B		x		
J1-B	J3-A		x	CB1 ON, CB4 ON	
J1-B	J3-A	x		CB1 OFF, CB4 ON	
J1-B	J3-A	x		CB1 ON, CB4 OFF	
J1-B	J3-V	x		CB1 ON, CB4 ON	
J1-B	J4-A		x	CB2 ON, CB4 ON	
J1-B	J4-A	x		CB2 OFF, CB4 OFF	
J1-B	J4-A	x		CB2 OFF, CB4 ON	

Change 2 3-4A/(3-4B blank)

Table 3-3. Power Distribution Network Resistance Measurements (Cont)

From	To	Resistance		Condition	Remarks	
		Inf.	Short			
J1-B	J5-A		x	CB3 ON, CB4 ON		
J1-B	JS-A	x		CB3 OFF, CB4 ON		
J1-B	J7-A		x	CB4 ON		
J7-A	J9-A		x			
J9-A	J11-A		x			
J1-B	J5-G		x	LIGHTS ON, Adj. DIM CW, CB4 ON		
J1-B	J5-G	50±2Ω		Adj. MAX CCW		
J1-B	J4-G	50±2Ω		Adj. MAX CCW		
J1-B	J3-G	50±2Ω		Adj. MAX CCW		
						J3,4,5,7,9,11

and shorts and verify proper circuitmade breaker operation. A short indication is considered less than 1 ohm. The infinite (Inf.) readings will show a changing reading due to the large filter capacitors. Perform checks under following conditions:

- No power connected
 - Radios not connected
 - Wind detector not connected
 - Lights - OFF
 - Voice Security Equipment, not connected
 - Transient suppressor, not connected
 - PUSH TO OPERATE, OFF
- b. Voltage Distribution Measurements. Voltage

measurements (table 3-4) are made using AN/USM-223 and with the following conditions:

- (1) +24 + 2.5 vdc applied J1-B(+), J1-A(-).
- (2) POWER ON/OFF switch to ON.
- (3) Wind speed and direction cable not connected.
- (4) Loosen eight captive fasteners on rear panel and lower panel.
- (5) Remove card enclosure cover for access to module test points.
- (6) Radios not connected.
- (7) RADIO 1, 2, 3 circuit breakers on rear panel, ON.
- (8) Turn off power before removing modules.

Table 3-4. Voltage Measurements

Measurement Point	Requirement	Note
Headset Amp: (A3) TBI-D(+) to TBI-F(-) TBI-E(+) to TBI-F(-)	+12.4 ± 0.1 vdc +24 ± 2.5 vdc	See figure 2-8.
Mic. Amp: (A2) TBI-C(+) to TBI-F(-)	+12.4 ± 0.1 vdc	See figure 2-6.
Lamp Indicator Circuit Boards: (No test points, see Note column)	+24 ± 2.5 v	Using hooks on module cover, remove modules A4-A6. Measure at J1-K, J2-K, J3-K to AITBI-F(-)
1A9A1J12-G to D 1A9A1J12-G to D 1A9A1J3-G(+) to V(-)	0 vac 26 vac ± 0.26 vac 400 Hz +24 ± 2.5 vdc	PUSH-TO-OPERATE, Pressed (OFF) PUSH-TO-OPERATE, Pressed (ON) LIGHTS ON, DIM Control Max brightness
1A9A1J4-G(+) to V(-)	+24 ± 2.5 vdc	LIGHTS ON, DIM Control Max brightness
1A9A1J5-G(+) to V(-)	+24 ± 2.5 vdc	LIGHTS ON, DIM Control Max brightness
1A9A1J5-G(+) to V(-)	Variable	LIGHTS ON, Vary DIM ccw to cw to ccw
1A9A1J3-A(+) to V(-) 1A9A1J4-A(+) to V(-) 1A9A1J5-A(+) to V(-) 1A9A1J7-A(+) to V(-)	+24 ± 2.5 vdc +24 ± 2.5 vdc +24 ± 2.5 vdc +24 ± 2.5 vdc	RADIO 1, Primary Power RADIO 2, Primary Power RADIO 3, Primary Power 24 vdc to TSEC/KY-38 or W1 Adapter Cable Assembly*
1A9A1J9-A(+) to V(-)	+24 ± 2.5 vdc	24 vdc to TSEC/KY-38 or W1 Adapter Cable Assembly*
1A9A1J11-A(+) to V(-)	+24 ± 2.5 vdc	24 vdc to TSEC/KY-38 or W1 Adapter Cable Assembly*

*W1 used with TSEC/KY-57 only (24 Vdc not provided to KY-57 via AN/TSQ-97).

Section II. TROUBLESHOOTING

3-6. Direct Support Troubleshooting Procedures.

a. *General.* The first step in isolating a trouble in the AN/TSQ-97 system is to sectionalize the fault. This means tracing the fault to a major assembly or component part such as a TSEC/KY-38, TSEC/KY-57, MK-2225/TSQ-97 installation kit, individual radio, control monitor or system cabling. Localizing means tracing the fault to the actual Dart or assembly responsible for failure.

b. *Sectionalizing.* The tests and measurements of Section II are arranged to minimize troubleshooting time for sectionalizing the trouble.

c. *Troubleshooting Chart.* Refer to table 3-5. Locate the symptom best matching the reported failure and take remedial action shown. Prior to replacing the part or assembly, verify failure by performing appropriate functional steps as listed under troubleshooting functional tests.

d. *Troubleshooting Interface Board 1A1A9A1.* If a signal applied to a rear panel does not get through to the control board, or a signal output from the control board is not measureable at the appropriate rear panel connectors, refer to FO-6 and make appropriate pin to pin and pin to ground ohmmeter measurements to determine if the control board is at fault.

e. *Electrical Schematic Diagrams* The following electrical foldout diagrams are presented as the last section of this manual:

- (1) FO-1. Cabling Diagram, AN/TSQ-97 System.
- (2) FO-1A. Cabling Diagram, MK-2225/TSQ-97 Installation Kit.
- (3) FO-2. Composite Electrical Schematic Diagram, Control Monitor C-9921/TSQ-97.

- (4) FO-3. Electrical Schematic Diagrams for AN/TSQ-97 system cables, MK-2225/TSQ-97 Installation Kit Cables, 50 Foot Power Cable, ML-653/TSQ-97 and Choke MX-9713/TSQ-97.
- (5) FO-4. Electrical Schematic Diagram, Rear Panel Assembly 1A1A9.
- (6) FO-5. Electrical Schematic Diagram, Card Enclosure Assembly 1A1A1.
- (7) FO-6. Electrical Schematic Diagram, Interface Circuit Board Assembly 1A1A1A9.
- (8) FO-7. Electrical Schematic Diagram, Front Panel Assembly 1A1A8.
- (9) FO-8. Electrical Schematic Diagram, Control Board Assembly 1A1A7.

f. *Troubleshooting Functional Tests.* Refer to the appropriate step that lists the major function displaying questionable performance. Using the procedures, test equipment and troubleshooting figure listed in the referenced table, troubleshoot the function.

- (1) Receive Clear Audio, Signal Tests and Measurements:
 - Radio 1 position, see table 3-6.
 - Radio 2 position, see table 3-7.
 - Radio 3 position, see table 3-8.

(2) Receive X-Mode Signal (cipher text) Tests and Measurements:

Radio 1 position, see table 3-9.

Radio 2 position, see table 3-10.

Radio 3 position, see table 3-11.

(3) Transmit Clear Audio, Signal Tests and Measurements:

Radio 1 position, see table 3-12

Radio 2 position, see table 3-13.

Radio 3 position, see table 3-14.

(4) Transmit X-Mode Signal (cipher text) Tests and Measurements:*

Radio 1 position, see table 3-15.

Radio 2 position, see table 3-16.

Radio 3 position, see table 3-17.

*These tests require fabrication and use of a resistive adapter pad as shown in figure 3-2.

(5) Antenna (Power Output) Signal Tests and Measurements - table 3-18.

(6) Wind Speed Tests - table 3-19.

(7) Wind Direction Test - paragraph 3-7.

Table 3-5. Troubleshooting Chart

POWER DISTRIBUTION

Seq No.	Symptom	Probable Cause	Remedial Action
1	<p>a. No voltage indication on BATTERY meter.</p> <p>b. Meter reading very low.</p>	<p>Battery not connected</p> <p>Battery not charged.</p> <p>Defective battery.</p> <p>Defective adapter.</p> <p>Bad power cable.</p> <p>Open filter 1A9FL1.</p> <p>Internal cable connection A7W3P1 to A8WIJ4, loose or off.</p>	<p>Connect battery.</p> <p>Charge battery, see TM 11-6130-351-14.</p> <p>Replace battery</p> <p>Replace MX-4430/PRC-47.</p> <p>Replace cable.</p> <p>Replace 1A9FL1 at General Support.</p> <p>See FO-2, make continuity checks. Make required repairs.</p>
2	<p>BATTERY meter indicates normal, but battery can't power any circuit</p>	<p>Defective POWER OFF/ON circuit breaker.</p>	<p>Replace A8CB4.</p>
3	<p>a. No power to Radio 1.</p> <p>b. Power to radio, but radio not operable.</p>	<p>RADIO 1 CIRCUIT BREAKER set to OFF.</p> <p>Defective RADIO 1 CIRCUIT BREAKER.</p> <p>Defective radio cable.</p> <p>Change 2 3-8</p>	<p>Set circuit breaker 1A1A9CB1 to ON.</p> <p>Replace circuit breaker 1A1A9CB1.</p> <p>Replace cable.</p>

Table 3-5. Troubleshooting Chart (Cont)

Seq No.	Symptom	Probable Cause	Remedial Action
3 (Cont)		Blown or missing fuse on radio back panel. Defective radio.	Replace fuse (FMO2A125V 5A) Replace radio.
4	a. No power to Radio 2.	RADIO 2 CIRCUIT BREAKER set to OFF	Set circuit breaker A9CB2 to ON.
		Defective RADIO 2 CIRCUIT BREAKER.	Replace 1A1A9CB2.
	b. Power to Radio 2, but radio not operable.	Defective radio cable. Blown or missing fuse on radio back panel. Defective radio.	Replace cable. Replace radio fuse (FM02A125V 5A) Replace radio.
5	a. No power to Radio 3	RADIO 3 CIRCUIT BREAKER set to OFF. Defective RADIO 3 CIRCUIT BREAKER. Defective radio cable.	Set circuit breaker 1A1A9CB3 to ON. Replace 1A1A9CB3. Replace cable.
	b. Power to radio, but radio not operable.	Blown or missing fuse(s) on radio back panel.	Replace fuse F1 (FM01A12SV 5A).
6	a, No ac voltage for Wind Direction and Speed Detector ML-653/TSQ-97.	Blown fuse 1A1F1. Defective PUSH TO OPERATE switch (should measure 26 vac, at 1A1TB1-3 to 4). Defective DC/AC inverter. Defective inverter filter.	Replace 1A1F1 (FPM02A125V 1.5A). Replace 1A1A8S7. Replace 1A1A11PSI. Adjust output to 26 ± .26 vac. See 3-13. Replace 1A1A12.
	b. No ac voltage for Wind Direction and Speed Detector, however, voltage measures ok at 1A1TB1-3 to -4.	Defective cable W401 or W402. Defective Radio Frequency Choke MX-9713/TSQ-97.	Replace cable(s). Replace choke (see figure FO-2 for schematic for continuity measurements).

Table 3-5. Troubleshooting Chart (Cont)

Seq No.	Symptom	Probable Cause	Remedial Action
7	Front panel lights and radio lights inoperative.	Defective LIGHTS ON-OFF MON-ON switch. Defective DIM control. Burned out lamps.	Replace 1A1A8S5. Replace 1A1A8R2. Replace lamps (see TM 11-5895-800-2, table 4-1).
8	Front panel lights for Radio 1, Radio 2 or Radio 3 do not light.	Defective Radio 1, 2 or 3 cable.	Replace cable.
<u>RECEIVE CLEAR/SECURE AUDIO</u>			
9	RADIO 1, 2 or 3 AUDIO indicator lamp does not light during transmit or receive. Audio is present and push-to-test check is good.	Volume control set wrong on radio. Defective radio cable. Defective (Radio 1, 2 or 3) lamp indicator circuit board 1A1A4-1A1A6.	Increase radio volume. Replace cable. Replace circuit board.
10	Received audio heard at loudspeaker, but not at headset.	Defective headset/sic. 1A1A8A1FL2 open.	Replace HDST/MIC. Replace 1A1A8A1FL2*
11	Received audio heard at headset but not at loudspeaker.	Defective SPKR-EDST HDST switch. Defective audio transformer T1. Defective loudspeaker.	Replace 1A1A8S4.* Replace 1A1A8T1.* Replace 1A1A10LS1.
12	For a particular radio AUDIO lamp lit, but no audio heard.	Defective VOL control. Defective Radio 1, 2 or 3 XMT-OFF-MON switch. Defective Headset Amplifier board 1A1A3. Defective control board 1A1A7. Internal wiring.	Replace 1A1A8R1.* Replace: 1A1A8S1, or* 1A1A8S2, or 1A1A8S3.* Replace 1A1A3. Make Receive Audio Checks. See tables 3-6, 3-7, 3-8. Replace 1A1A7 if tests fail. Make continuity checks, see F0-2. Take required action.

*Replace at General Support

Table 3-5. Troubleshooting Chart (Cont)

Seq No.	Symptom	Probable Cause	Remedial Action
13	Cannot receive cipher text with XMT MODE switch on SEC 1, SEC 2, SEC 3 or NORM.	<p>Malfunction in TSEC/KY-38 or TSEC/KY-57.</p> <p>TSEC/KY-38 PLAIN/CIPHER switch set to PLAIN or OFF.</p> <p>TSEC/KY-57 MODE switch set to LD, RV, or P.</p> <p>Defective secure control cable.</p> <p>Defective secure signal cable.</p> <p>Defective adapter cable assembly.</p> <p>Defective receive audio switching relay on control board 1A1A7.</p> <p>Defective radio.</p> <p>Defective disable relay.</p>	<p>Set switch to another position. If trouble still occurs, send TSEC/KY-38 or TSEC/KY-57 to designated repair point. Set switch to CIPHER.</p> <p>Set switch to C.</p> <p>Replace cable.</p> <p>Replace cable.</p> <p>Replace cable assembly.</p> <p>Replace 1A1A7 circuit board (see figure 2-18).</p> <p>Replace radio.</p> <p>Replace 1A1A12.</p>
14	Insufficient audio volume with radio volume and facility VOL controls properly set.	<p>Defective radio.</p> <p>Defective headset.</p> <p>Amplifier board.</p> <p>Defective lamp - indicator board.</p>	<p>Replace radio.</p> <p>Replace 1A1A3.</p> <p>Replace A1A4-A6 as applicable.</p>
15	Radio 1, 2 or 3 AUDIO lamp does not light during transmit function. Audio tone is present.	<p>TRANSMIT CLEAR/SECURE AUDIO</p> <p>Burned out lamp (verify with Press-to-Test).</p> <p>Radio VOL or AUDIO control not set to sufficient level.</p> <p>Defective radio cable.</p> <p>Defective lamp indicator board.</p>	<p>Replace lap.</p> <p>Increase to point where lamp lights during transmission.</p> <p>Replace radio cable.</p> <p>Replace 1A1A4-A6 as applicable.</p>

Change 2 3-11

Table 3-5. Troubleshooting Chart (Cont)

Seq No.	Symptom	Probable Cause	Remedial Action
16	<p>Cannot transmit in clear or X-mode.</p> <p>a. On one particular radio.</p> <p>b. All radios.</p> <p>c. When a particular radio is keyed in X-mode, more than one AUDIO lamp is lit.</p>	<p>Defective XMT MODE switch.</p> <p>Defective XMT-OFF-MON switch.</p> <p>Open diode in keying circuit. (RADIO 1, A7CR1 or A9A1CR4.) (RADIO 2, A7CR5 or A9A1CR5.) (RADIO 3, A7CR6 or A9A1CR6.)</p> <p>Defective radio cable.</p> <p>Defective radio to choke cable.</p> <p>Defective choke to antenna cable.</p> <p>Defective radio.</p> <p>Defective microphone.</p> <p>Defective XMT cont relay Input filter open.</p> <p>Defective microphone amplifier board. Battery voltage too low.</p> <p>Defective relay A12K-1,-2, or -3.</p>	<p>Replace 1A1A8S6.*</p> <p>Replace 1A1A8S1, S2 or* S3 as applicable.</p> <p>Replace control board 1A1A7 (see fig. 2-19) or interface board 1A1A9A1.</p> <p>Replace cable.</p> <p>Replace W201, W202, or W203.</p> <p>Replace W301, W302, or W303.</p> <p>Try radio in another radio position. If trouble moves to that position, replace radio.</p> <p>Replace microphone.</p> <p>Replace 1A1A8K1.* Replace 1A1A8A1FL3.*</p> <p>Replace 1A1A2.</p> <p>Replace battery.</p> <p>Isolate and replace defective relay</p>

*Replace at General Support

Table 3-5. Troubleshooting Chart (Cont)

Seq No.	Symptom	Probable Cause	Remedial Action
17	<p>No sidetone audio heard during transmission.</p> <p>a. AUDIO light doesn't light.</p> <p>b. AUDIO lamp lit.</p> <p>c. For a particular radio, no side-tone is heard during X-mode transmission.</p>	<p>Defective microphone amplifier board. Open input filter. Defective radio cable.</p> <p>Defective lamp indicator board</p> <p>Defective headset amplifier board.</p> <p>Radio VOL or AUDIO control not set to proper level. is lit.</p> <p>Defective control board.</p> <p>Defective headset amplifier board.</p> <p>Defective XMT-OFF-MON switch.</p> <p>Defective audio disable circuitry.</p> <p>Defective relay for that radio.</p>	<p>Replace 1A1A2.</p> <p>Replace 1A1A8A1FL4.* Replace cable.</p> <p>Replace 1A1A4, A5,or A6.</p> <p>Replace 1A1A3.</p> <p>Adjust to comfortable level where AUDIO lamp is lit.</p> <p>Replace 1A1A7.</p> <p>Replace 1A1A3.</p> <p>Replace 1A1A8S1, S2,or* S3 as applicable.</p> <p>Replace 1A1A7 control board.</p> <p>Replace relay (1A1A12K-1, -2, or -3)</p>
18	<p>When any one radio is keyed, the audio from the other radios is heard mixed in with the normal sidetone of the keyed radio.</p>	<p>Defective audio disable circuitry</p>	<p>Replace control board 1A1A7 (fig. 2-17, 2-19).</p>
19	<p>Individual radio circuit breaker won't stay ON.</p>	<p>Defective radio. Impedance mismatch.</p>	<p>Replace radio. Check ant. connections.</p>

*Replace at General Support

Table 3-5. Troubleshooting Chart (Cont)

Seq No.	Symptom	Probable Cause	Remedial Action
<u>WIND DIRECTION AND SPEED DETECTOR</u>			
20	No wind direction indication.	Defective cable from detector to choke, Defective cable from choke to control monitor IA9AIJ12. Defective choke. Blown fuse. Defective DC/AC inverter. Defective Inverter filter. Defective PUSH TO OPERATE switch.	Replace W402. Replace W401. Replace MX-9713/TSQ-97. Replace 1A1F1 (1.5A). Replace 1A1A11PSI. Replace 1A1FL1. Replace 1A1A8S7.*
21	No WIND SPEED indication.	Defective WIND DIRECTION indicator. Defective Wind Speed and Direction Detector. Defective circuit on control board 1A1A7. Defective cable from detector to choke. Defective cable from choke to control monitor 1A1A9A1J12. Defective Wind Speed and Direction Detector. Defective WIND SPEED meter. Defective circuitry on control board.	Replace 1A1A8ID-1. Replace ML-653/TSQ-97. Replace 1A1A7. Replace W402. Replace W401. Replace ML-653/TSQ-97. Replace 1A1A8M1. Replace 1A1A7.

*Replace at General Support.

Table 3-5A. Troubleshooting Chart (Cont)

Test No.	Procedure	Troubleshooting Figure
1	<p>a. Check MK-2225/TSQ-97 Installation Kit cables, W1 adapter cables, and available 50 foot power cable for continuity using the listed schematic diagrams.</p> <p>b. Use DC power supply to energize W1 adapter cable relays K1, K2, and K3 in order to check relay operation and associated circuit continuity</p> <p style="text-align: center;">Change 2 3-14A/(3-14B blank)</p>	Figures 2-11A and FO-3.

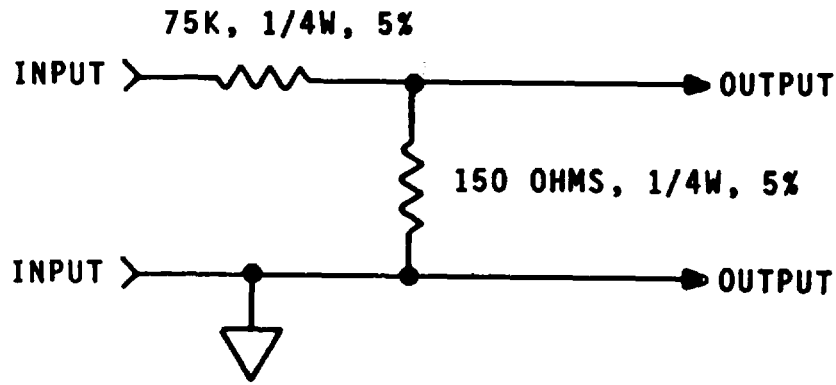

ELOST 026

Figure 3-2. Resistor Pad

Table 3-6. Radio 1 Position, Receiver Clear Audio Signal Tests and Measurements

Equipment Required: Audio Oscillator TS-421/U
Multimeter AN/USM-223

Test No.	Procedure	Troubleshooting Figure. Further Tests
-	Test Conditions: a. Radios disconnected b. Security Equipment disconnected c. Storage Battery BB-451/U or suitable power supply connected to J1-B(+) and J1-A(-).	
1	Set RADIO 1, 2, 3 CIRCUIT BREAKERS to OFF.	
2	Set XMT-OFF-MON switch (Radio 1) to MON. Set to OFF for Radio 2 and 3.	
3	Place the POWER OFF-ON switch on control monitor to ON.	
4	Set XMT MODE switch to NORM.	
5	Adjust control monitor VOL control to maximum (cw).	

Table 3-6. Radio 1 Position, Receiver Clear Audio Signal Tests and Measurements

Test No.	Procedure	Troubleshooting Figure. Further Tests
6	Place HDST-SPKR-HDST switch to HDST.	
7	Apply a 1 KHz + 100 Hz, 3.0 ± 0.3 vrms to J3-D (high) and J3-E (low).	Figures 2-17, 2-18, 2-18A, FO-2
8	Adjust multimeter to read 3.0 vrms.	 <p data-bbox="1295 632 1396 684">J13 HDST/MIC</p>
9	Connect multimeter to HDST MIC connector J13-B (high) and chassis ground (J13-A).	
10	Multimeter shall indicate 2.0 vrms minimum.	
11	Place SPKR HDST switch to SPKR HDST position. The 1 KHz input shall be audible.	<p data-bbox="857 716 1279 1171">If results of steps 10-12 are not as required, make test point measurements at lamp indicator Board A4 (fig. 2-9) and Headset Amplifier Board A3 (fig. 2-8). If normal indications are not obtained, replace the board and repeat tests. If IAIA2 is changed, make microphone amplifier gain adjustment as directed in Section III, Maintenance Procedures. If tests still are not satisfactory, refer to FO-2 and make measurements along the audio path to locate the failure point.</p>
12	The AUDIO indicator for RADIO 1 shall be lit. The other two AUDIO lamps shall not be lit.	
13	Connect a jumper from J6-F to chassis ground. Audio tone goes OFF.	
14	Remove jumper. Tone is audible.	Receive audio relay 1A7K2 is energized.
15	Lower oscillator output until the AUDIO lamp goes out. The oscillator output shall be 0.5 vrms minimum at this point.	Checks lamp board threshold of operation.
16	Increase oscillator output until the AUDIO indicator lights. The oscillator output shall be 0.75 ± 0.10 vrms at this point.	

Table 3-7. Radio 2 Position, Receive Clear Audio Signal Tests and Measurements

Equipment Required:

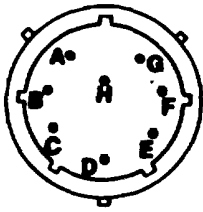
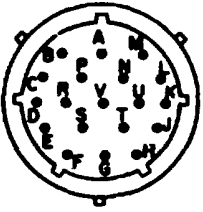
Audio Oscillator TS-421/U
Multimeter AN/USM-223

Test No.	Procedure	Troubleshooting Figure, Further Tests
-	Test Conditions: a. Radios disconnected. b. Security Equipment disconnected. c. Storage Battery BB-451/U or suitable Power Supply connected to J1-B(+) and J1-A(-)	
1	Set RADIO 1, 2, 3 CIRCUIT BREAKERS to OFF.	
2	Set XMT-OFF-ON switch (Radio 2) to MON. Set to OFF for Radio 1 and 3.	
3	Place the POWER OFF-ON switch on control monitor to ON.	
4	Set XMT MODE switch to NORM.	
5	Adjust Control Monitor VOL control to maximum (cw).	
6	Place HDST-SPKR-HDST switch to HDST.	
7	Apply a 1 KHz i 100 Hz, 3.0 ± 0.3 vrms to J4-D (high) and J4-E (low).	<p>Figures 2-17, 2-18, 2-18A, FO-2. Note figures 2-17, 2-18, 2-18A show only the RADIO 1 paths.</p> 
8	Adjust multimeter to read 3.0 vrms.	 <p>HDST/MIC</p>
9	Connect multimeter to HDST MIC connector J13-B (high) and chassis ground (J13-A).	
10	Multimeter shall indicate 2.0 vrms minimum.	<p>If results of steps 10-12 are not as required, make test point measurements at Lamp Indicator Board A5 (fig. 2-9) and Headset Amplifier Board A3 (fig. 2-8). If normal indications are not obtained, replace the board and repeat tests. If microphone amplifier is changed, verify gain adjustment per instructions in Section III.</p>
11	The AUDIO indicator for RADIO 2 shall be lit. The other two AUDIO lamps shall not be lit.	
12	Place SPKR-HDST switch to SPKR HDST position. The 1 KHz input shall be audible.	

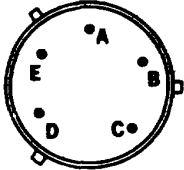
Table 3-7. Radio 2 Position, Receive Clear Audio, Signal Tests and Measurements

Test No.	Procedure	Troubleshooting Figure. Further Tests
13	Connect a jumper from J8-F to chassis ground. Audio tone goes OFF.	<p>If tests still are not satisfactory, refer to FO-2 and make measurements along the audio path to locate the failure point.</p> <p>Receive audio relay IA7KS is energized.</p> <p>Checks lamp board threshold of operation.</p>
14	Remove jumper. Tone is audible.	
15	Lower oscillator output until the AUDIO lamp goes out. The oscillator output shall be 0.5 vrTs inium 'at this point.	
16	Increase oscillator output until the AUDIO indicator lights. The oscillator output shall be 0.75 S 0.10 vrms at this point.	

Table 3-8. Radio 3 Position, Receive Clear Audio Signal tests and Measurements

Equipment Required:

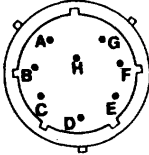
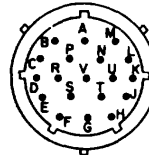
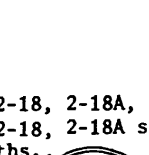
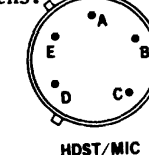
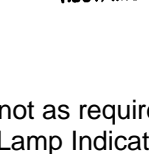
**Audio Oscillator TS-421/U
Multimeter AN/USM-223**

Test No.	Procedure	Troubleshooting Figure. Further Tests
-	<p>Test Conditions:</p> <ul style="list-style-type: none"> a. Radios disconnected. b. Security Equipment disconnected. c. Storage Battery BB-451/U or suitable power supply connected to J1-B(+) and J1-A(-). 	
1	Set RADIO 1, 2, 3 CIRCUIT BREAKERS to OFF.	

Table 3-8. Radio 3 Position, Receive Clear Audio, Signal Tests and Measurements

Test No.	Procedure	Troubleshooting Figure. Further Tests
2	Set XMT-OFF-MON switch (Radio 3) to MON. Set to OFF for Radio 1 and 2.	
3	Place the POWER OFF-ON switch on control monitor to ON.	
4	Set XMT-MODE switch to NORM.	 
5	Adjust Control Monitor VOL control to maximum (cw).	
6	Place HDST-SPKR-HDST switch to HDST.	<p data-bbox="906 709 1360 779">Figures 2-17, 2-18, 2-18A, FO-2. Note figures 2-17, 2-18, 2-18A show only RADIO 1 paths.</p>  <p data-bbox="1094 919 1187 940">HDST/MIC</p>
7	Apply a 1 KHz + 100 Hz, 3.0 + 0.3 vrms to JS-D (high) and J5-E (low).	
8	Adjust multimeter to read 3.0 vrms.	
9	Connect multimeter to HDST MIC connector J13-B (high) and chassis ground (J13-A).	
10	Multimeter shall indicate 2.0 vrms minimum.	<p data-bbox="938 989 1511 1325">If results of steps 10-121 are not as required, make test point measurements at Lamp Indicator Board A6 (fig. 2-9) and Headset Amplifier Board A3 (fig. 2-8). If one of the circuit cards does not indicate properly, change the board for a known good board and repeat tests. If microphone amplifier is changed, verify gain Adjustment per instruction in Section III. If tests are not satisfactory, refer to FO-2 and make measurements along the audio path to locate the failure point.</p>
11	The AUDIO indicator for RADIO 1 shall be lit. The other two AUDIO lamps shall not be lit.	
12	Place SPKR HDST switch to SPKR-HDST position. The 1 KHz input shall be audible.	
13	Connect a jumper from J10-F to chassis ground. Audio tone goes OFF.	<p data-bbox="938 1415 1422 1446">Receive audio relay 1A7K8 is energized.</p>
14	Remove jumper. Tone is audible.	

Table 3-8. Radio 3 position, Receive Clear Audio, Signal Tests and Measurements (Cont)

Test No.	Procedure	Troubleshooting Figure. Further Tests
15	Lower oscillator output until the AUDIO lamp goes out. The oscillator output shall be 0.5 vrms minimum at this point.	Checks lamp board threshold of operation.
16	Increase oscillator output until the AUDIO indicator lights. The oscillator output shall be 0.75 + 0.10 vrms at this point.	

Table 3-9. Radio 1 Position, Receive Secure Signal (Cipher Text) Test and Measurements

Equipment Required:

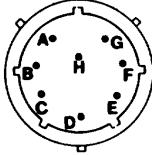
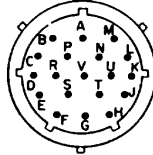
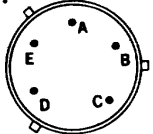
**Audio Oscillator TS-421/U
Multimeter AN/USM-223**

Test No.	Procedure	Troubleshooting Figure. Further Tests
- a. b.	Test Conditions: Radios disconnected. Security equipment disconnected.	Figures 2-17, 2-18, 2-18A, FO-2. Note figures 2-17, 2-18, 2-18A show only RADIO 1 circuit paths.
c.	Storage Battery BB-451/U or suitable power supply connected to J1-B(+) and J1-A(-).	
1	Set RADIO 1, 2, 3 CIRCUIT BREAKERS to OFF.	
2	Set the XMT-OFF-MON switch (RADIO 1) to MON. Set to OFF for Radios 2 and 3.	
3	Place POWER OFF-ON switch on control monitor to ON. Set SPKR-HDST switch to HDST.	

Table 3-9. Radio 1 Position, Receive Secure Signal (Cipher Text) Test and Measurements

Test No.	Procedure	Troubleshooting Figure. Further Tests
4	Adjust Control Monitor VOL control to maximum (cw).	
5	Set XMT MODE switch to SECURE RADIO 1.	
6	Ground J7-M and J13-C. Set multi-meter to lowest ohms scale.	X-MODE Control Relay 1A7K10 Energizes.
7	Measure continuity from J3-F to chassis ground. The resistance shall be less than 5 ohms.	See figures 2-18, 2-18a.
8	Remove jumpers. Meter shall indicate infinite resistance on highest scale.	
9	Apply a 1 KHz + 1 Hz, 0.175 + 0.025 vrms signal between J7-D and chassis ground.	
10	Adjust the multimeter to read 3 vrms.	 <p data-bbox="1019 1224 1169 1297">J13 HDST/MIC</p>
11	Connect multimeter to J13-B(+) and J13-A(-).	
12	Meter shall indicate 0.25 vrms min. Remove meter.	
13	Set HDST SPKR switch to SPKR HDST. Applied audio signal is heard from speaker.	
14	Ground J6-F. Audio tone not heard.	Clear /X-MODE audio switching relay 1A7K2 energizes.
15	Apply signal (see step 9) to J6-C. Audio is heard.	<p data-bbox="938 1539 1510 1730">If the results of step 12 are not as required, apply signal as per step 9. Test the circuit boards by making test point measurements at lamp board A4 and Headset Amplifier board A2. Change boards if necessary. If trouble persists refer to FO-2. Make continuity checks to isolate the failure.</p>
16	Remove all connections.	

Table 3-10. Radio 2 Position, Receive Secure Signal (Cipher Text) Test and Measurements

Equipment Required:		Audio Oscillator TS-421/UTM
Test No.	Procedure	Troubleshooting Figure, Notes
	<p>Test conditions:</p> <ul style="list-style-type: none"> a. Radios disconnected. b. Security equipment disconnected. c. Storage Battery BB-451/U or suitable power supply connected to J1-B(+) and J1-A(-). 	<p>Figures 2-17, 2-18, 2-18A, FO-2. Note figures 2-17, 2-18, 2-18A show only the RADIO 1 circuit paths.</p>
1	Set RADIO 1, 2, 3 CIRCUIT BREAKERS to OFF.	
2	Set the XMT-OFF-MON switch (RADIO 2) to MON. Set to OFF for Radios 1 and 3.	
3	Place POWER OFF-ON switch on Control Monitor to ON. Set SPKR-HDST switch to HDST.	
4	Adjust Control Monitor VOL control to maximum (cw).	
5	Set XMT MODE switch to SECURE RADIO 2.	
6	Ground J9-M and J13-C. Set multimeter to lowest ohms scale.	X-MODE Control Relay 1A7K10 energizes.
7	Measure continuity from J4-F to chassis ground. The resistance shall be less than 5 ohms.	See figures 2-18, 2-18A.
8	Remove jumpers. Meter shall indicate infinite resistance on highest scale.	
9	Apply a 1 KHz \pm 1 Hz, 0.175 \pm 0.025 vrms signal between J9-D and chassis ground.	
10	Adjust the multimeter to read 3 vrms.	
11	Connect multimeter to J13-B(+) and J13-A(-).	

Table 3-10. Radio 2 Position, Receive Secure Signal (Cipher Text) Test and Measurements (Cont)

Test No.	Procedure	Troubleshooting Figure. Further Tests
12	Meter shall indicate 0.25 vrms min. Remove meter.	<p>Clear/X-MODE audio switching relay 1A7K5 energizes.</p> <p>If the results of step 12 are not as required, apply signal as per step 9. Test the circuit boards by making test point measurements at lamp board A5 and Headset Amplifier board A2. Change boards if necessary. If trouble persists refer to FO-2. Make continuity checks to isolate the failure.</p>
13	Set HDST-SPKR switch to SPKR HDST. Applied audio signal is heard from speaker.	
14	Ground J8-F. Audio tone not heard.	
15	Apply signal (see step 9) to J8-C. Audio is heard.	
16	Remove all connections.	

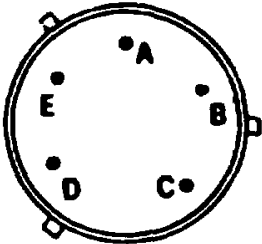
Table 3-11. Radio 3 Position, Receive Secure Signal (Cipher Text) Tests and Measurements

**Equipment Required: Audio Oscillator TS-421?u
Multimeter AN/ASM-223**

Test No.	Procedure	Troubleshooting Figure. Further Tests
	<p>Test conditions:</p> <ul style="list-style-type: none"> a. Radios disconnected. b. Security equipment disconnected. c. Storage Battery BB-451/U or suitable power supply connected to J1-B(+) and J1-A(-). 	<p>Figures 2-17, 2-18, 2-18A, FO-2. Note figures 2-17, 2-18, 2-18A show only RADIO 1 circuit paths.</p>

Table 3-11. Radio 3 Position, Receive Secure Signal (Cipher Text) Test and Measurements (Cont)

Test No.	Procedure	Troubleshooting Figure. Further Tests
1	Set RADIO 1, 2, 3 CIRCUIT BREAKERS to OFF.	
2	Set the XMT-OFF-MON switch (RADIO 3) to M(N. Set to OFF for Radios 1 and 2.	
3	Place POWER OFF-ON switch on Control Monitor to ON. Set SPKR-HDST switch to HDST.	
4	Adjust Control Monitor VOL control to maximum (cw).	
5	Set XMT MODE switch to SECURE RADIO 3.	
6	Ground J11-M and J13-C. Set multi-meter to lowest ohms scale.	X-MODE Control Relay 1A7KO1 energizes.
7	Measure continuity from J5-F to chassis ground. The resistance shall be less than 5 ohms.	See figures 2-18, 2-18A.
8	Remove jumpers. Meter shall indicate infinite resistance on highest scale.	
9	Apply a 1 KHz + 1 Hz, 0.175 + 0.025 vrms signal between J11-D and chassis ground.	
10	Adjust the multimeter to read 3 vrms.	
11	Connect multimeter to J13-B(+) and J13-A(-).	
12	Meter shall indicate 0.25 vrms min. Remove meter.	
13	Set HDST-SPKR switch to SPKR HDST. Applied audio signal is heard from speaker.	

Table 3-11 . Radio 3 Position, Receive Secure Signal (Cipher Text) Test and Measurements (Cont)

Test No.	Procedure	Troubleshooting Figure. Further Tests
14	Ground J10-F.	Audio tone not heard. Clear/X-MODE audio switching relay 1A7K8 energizes.
15	Apply signal (see step 9) to J10-C. Audio is heard.	
16	Remove all connections.	

If the results of step 12 are not as required, apply signal as per step 9. Test the circuit boards by making test point measurements at lamp board A6 and Headset Amplifier board A2. Change boards if necessary. If trouble persists refer to FO-2. Make continuity checks to isolate the failure.

Table 3-12. Radio 1 Position, Transmit Clear Audio Signal (Test and Measurements

Equipment Required:

**Audio Oscillator TS-421/U
Resistive (1000:1) adapter
pad, as shown in figure 3-2
Multimeter AN/ASM-223**

Test No.	Procedure	Troubleshooting Figure. Further Tests
1	<p>Test Conditions:</p> <ul style="list-style-type: none"> a. Radios disconnected. b. Security equipment disconnected. c. Storage Battery BB-451/U or suitable power supply connected to J1-B(+) and J1-A(-). <p>Place RADIO 1, 2, 3 CIRCUIT BREAKERS (on Control Monitor rear panel) to OFF.</p>	

Table 3-12. Radio 1 Position, Transmit Clear Audio, Signal Tests and Measurements (Cont)

Test No.	Procedure	Troubleshooting Figure. Further Tests
2	Place Control Monitor POWER OFF-ON switch to ON.	
3	Place RADIO 1 XMT-OFF-MON switch to XMT. Place RADIO 2 and RADIO 3 XMT-OFF-MON switch to OFF.	
4	Place XMT-MODE switch to NORM.	
5	Adjust the oscillator to deliver a frequency of 1 KHz \pm 100 Hz at a level of 0.6 \pm 0.025 vrms.	
6	Connect the oscillator through the (1000:1) resistor pad (see figure 3-2) to the HDST MIC connector as follows: J13-D (high) and J13-E (low).	
7	Adjust the multimeter to read 3 vrms maxim.	<p>Modulation input line test.</p>  <p>The diagram shows a circular connector with five terminals labeled A, B, C, D, and E. Terminal A is at the top, B is on the right, C is at the bottom right, D is at the bottom left, and E is on the left.</p>
8	Connect the multimeter between J3-K (high) and J3-V (low). The meter shall indicate 0.40 (+.04, -.12) vrms. If necessary make microphone amplifier gain adjustment as listed in Section III.	<p>Figure 2-15. If results of steps 8 and 9 are not as required make test point measurements at the microphone amplifier (fig. 2-6).</p>
9	Connect the multimeter between J7-U (high) and J7-V (low). The meter shall indicate 0.4 (+.04, -.12) vrms. Remove meter.	 <p>The diagram shows a circular connector with many terminals labeled with letters from A to Z. The labels are arranged in a circular pattern around the perimeter of the connector.</p>

Table 3-13. Radio 2 Position, Transmit Clear Audio Signal Tests and measurements

Equipment Required:

**Audio Oscillator TS-421/U
Resistive (1000:1) adapter
pad, as shown in figure 3-2
Multimeter AN/ASM-223**

Test No.	Procedure	Troubleshooting Figure. Further Tests
1	<p>Test Conditions: a. Radios disconnected b. Security equipment disconnected. c. Storage Battery BB-451/U or suitable power supply connected to J1-B(+) and J1-A(-). Place RADIO 1, 2, 3 CIRCUIT BREAKERS (on Control Monitor rear panel) to OFF.</p>	
2	<p>Place Control Monitor POWER OFF-ON switch to ON.</p>	
3	<p>Place RADIO 2 XMT-OFF-MON switch to XMT. Place RADIO 1 and RADIO 3 XMT-OFF-MON switch to OFF.</p>	
4	<p>Place XMT-MODE switch to NORM.</p>	
5	<p>Adjust the oscillator to deliver a frequency of 1 KHz \pm 100 Hz at a level of 0.6 + 0.025 vrms.</p>	
6	<p>Connect the oscillator through the (1000:1) resistor pad (see figure 3-2) to the HDST MIC connector as follows: J13-D (high) and J13-E (low).</p>	<p>Modulation input line test.</p>
7	<p>Adjust the multimeter to read 3 vrms maximum.</p>	
8	<p>Connect the multimeter between J4-K (high) and J4-V (low). The meter shall indicate 0.40 (+.04, -.12) vrms. If correct results are not obtained, make microphone amplifier gain adjustment as covered in Section III.</p>	<p>Figure 2-15. If results of steps 8 and 9 are not as required make test point measurements at the microphone amplifier (fig. 2-6).</p>

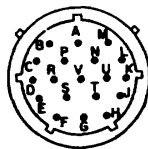
Table 3-13. Radio 2 Position, Transmit Clear Audio Signal Tests and Measurements (Cont)

Test No.	Procedure	Troubleshooting Figure. Further Tests
9	Connect the multimeter between J9-U (high) and J9-V (low). The meter shall indicate 0.4 (+.04, -.12) vrms.	

Table 3-14. Radio 3 Position, Transmit Clear Audio Signal Tests and Measurements

Equipment Required:

**Audio Oscillator TS-421/U
Resistive (1000:1) adapter
pad, as shown in figure 3-2
Multimeter AN/ASM-223**

Test No.	Procedure	Troubleshooting Figure. Further Tests
	<p>Test Conditions:</p> <ul style="list-style-type: none"> a. Radios disconnected. b. Security equipment disconnected. c. Storage Battery BB-451/U or suitable power supply connected to J1-B(+) and J1-A(-). 	
1	Place RADIO 1, 2, 3 CIRCUIT BREAKERS (on Control Monitor rear panel) to OFF.	
2	Place Control Monitor POWER OFF-ON switch to ON.	
3	Place RADIO 3 XMT-OFF-MON switch to XMT. Place RADIO 1 and RADIO 2 XMT-OFF-MON switch to OFF.	
4	Place XMT-MODE switch to NORM.	
5	Adjust the oscillator to deliver a frequency of 1 KHz + 100 Hz at a level of 0.6 + 0.025 vrms.	

Table 3-14. Radio 3 Position, Transmit Clear Audio, Signal Tests and Measurements (Cont)

Test No.	Procedure	Troubleshooting Figure. Further Tests
6	Connect the oscillator through the (1000:1) resistor pad (see figure 3-2) to the HDST MIC connector as follows: J13-D (high) and J13-E (low).	Modulation input line test. Figure 2-15. If results of steps 8 and 9 are not as required make test point measurements at the microphone amplifier (fig. 2-6).
7	Adjust the multimeter to read 3 vrms maximum.	
8	Connect the multimeter between JS-K (high) and J5-V (low). The meter shall indicate 0.4 (+.040, -.12) vrms. If correct results are not obtained, make microphone amplifier gain adjustment as covered in Section III.	
9	Connect the multimeter between J11-U (high) and J11-V (low). The meter shall indicate 0.4 (+.04, -.12) vrms.	

Table 3-15. Radio 1 Position, Secure Transmit Signal Tests and Measurements

Equipment Required:

**Audio Oscillator TS-421/U
Multimeter AN/ASM-223
Resistive adapter pad (1000:1)
as shown in figure 3-2**

Test No.	Procedure	Troubleshooting Figure. Further Tests
	<p>Test Conditions:</p> <ul style="list-style-type: none"> a. Radios disconnected. b. Security equipment disconnected. c. Storage Battery BB-451/U or suitable power supply connected to J1-B(+) and J1-A(-). 	

Table 3-15. Radio 1 Position, Secure Transmit Signal Tests and Measurements

Test No.	Procedure	Troubleshooting Figure. Further Tests
1	Set RADIO 1 XMT-OFF-MON switch to XMT. Set RADIO 2 and RADIO 3 XMT-OFF-MON switch to OFF.	Audio switching and attenuation test. Figures 2-15, 2-16, FO-2
2	Set XMT MODE to SECURE RADIO 1.	
3	Ground J7-M.	Relay A7K10 energizes
4	Adjust oscillator to deliver a frequency of 1 KHz + 100 Hz at an output level of 0.6 + 0.025 vrms.	
5	Connect the oscillator through the 1000:1 resistor pad (see figure 3-2) to the HEADSET MIC connector as follows: J13-D (high) and J13-E (low).	 <p style="text-align: center;">J13 HDST/MIC</p>
6	Adjust multimeter to read 1.0 vrms.	
7	Connect multimeter between J6-E (high) and J6-H (low). Meter shall indicate 2.9 + 0.9 mvrms.	
8	Remove ground from J7-M. Meter shall indicate 0.40 +.04 ms. -.12	
9	Remove oscillator and pad from HDST MIC connector.	
10	Adjust multimeter to lowest ohms scale.	Keying circuit test. Figures 2-19, FO-2
11	Measure continuity between J6-D and ground with J13-C grounded. Meter shall indicate less than 1 ohm. Remove J13-C ground and meter shall indicate 1 megohm or greater.	
12	Connect ohmmeter, on ohms X 100 range, (-) lead to J3-H and (+) lead to J7-K. Meter shall indicate infinite resistance.	Measures diodes 1A7CR1, 1A1CR2. (a front-to-back ratio of at least 10:1 is normal).

Table 3-15. Radio 1 Position, Secure Transmit Signal, Tests and Measurements (Cont)

Test No.	Procedure	Troubleshooting Figure. Further Tests
13	Reverse ohmmeter leads. Meter shall measure front-to-back diode ratio.	
14	Connect ohmmeter to J3-L and J7-H. Meter shall indicate less than 2 ohms.	<p>Baseband/Diphase select test.</p> <p>Baseband/Diphase select test.</p>
15	Apply +9 vdc to J3-M. Ohmmeter shall indicate infinite resistance on highest ohms scale.	<p>Figures FO-2, 2-21. Baseband/Diphase Select relay 1A1A7K1</p>
16	Connect ohmmeter between J3-L and J7-F. Ohmmeter shall indicate less than 1 ohm.	
17	Connect ohmmeter between J7-H and chassis ground. Meter shall indicate less than 1 ohm.	
18	Remove +9 vdc from J3-M. Verify measurements of test numbers 15, 16, 17. Turn control monitor power switch off, then back on. Verify test 14 indication has returned.	

Change 1 3-30A/ (3-30B blank)

Table 3-15. Radio 1 Position, Secure Transmit Signal Tests and Measurements (Cont)

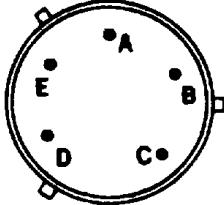
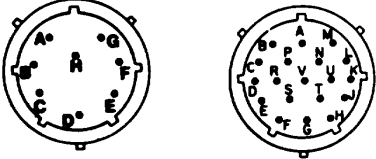
Test No.	Procedure	Troubleshooting Figure. Further Tests
19	Adjust multimeter to measure +24 vdc.	
20	Connect multimeter between J7-G and chassis ground. Meter shall indicate applied voltage (+24 v) +, -1.0 vdc.	
21	Apply +9 vdc to J3-M. Meter shall indicate 0 vdc.	
22	Adjust multimeter to read ohms on lowest scale.	
23	Connect ohmmeter between J7-J and chassis ground. Meter shall indicate less than 1 ohm.	
24	Remove +9 vdc from J3-M. Ohmmeter shall indicate less than 1 ohm.	
25	Turn off control monitor power switch and return to on. Ohmmeter shall indicate one megohm or greater.	

Change 1 3-31

Table 3-16. Radio 2 Position, Secure Transmit, Signal Tests and Measurements

Test No.	Procedure	Troubleshooting Figure. Further Tests
1	Set RADIO 2 XMT-OFF-MON switch to XMT. Set RADIO 1 and RADIO 3 XMT-OFF-MON switch to OFF.	
2	Set XMT MODE to SECURE RADIO 2. Figures 2-15, 2-16, FO-2.	Audio switching and attenuation test
3	Ground J9-M	Relay A7KO1 energizes.
4	Adjust oscillator to deliver a frequency of 1 KHz + 100 Hz at an output level of 0.6 + 0.1 vrms.	
5	Connect the oscillator through the 1000:1 resistor pad (see figure 3-2) to the HEADSET MIC connector as follows: J13-D (high) and J13-E (low).	
6	Adjust multimeter to read 10.0 mvrms.	
7	Connect multimeter between JS-E (high) and J8-H (low). Meter shall indicate 2.7 + 0.9 mvrms.	
8	Remove ground from J9-M. Meter shall indicate 0.4 ± 0.5 vrms.	
9	Remove oscillator from HDST MIC connector.	
10	Adjust multimeter to read ohms on the lowest scale.	Keying circuit test. Figures 2-19, FO-2.
11	Measure continuity between J8-D and ground with J13-C grounded. Meter shall indicate less than 1 ohm. Remove J13-C ground and ohm meter shall indicate 1 megohm or greater.	
12	Connect ohmmeter (-) lead to J4-H and (+) lead to J9-K. Meter shall indicate infinite resistance.	Measures diodes 1A7CR15, IAICR3. (a front-to-back ratio of at least 10: 1 is normal)

Table 3-16. Radio 2 Position, Secure Transmit Signal Tests and Measurements (Cont)

Test No.	Procedure	Troubleshooting Figure. Further Tests
13	Reverse ohmmeter leads. Meter shall measure diode front-to-back ratio.	
14	Connect ohmmeter to J4-L and J9-H. Meter shall indicate less than 1 .	Baseband/Diphase select test.
15	Apply +9 vdc to J4-M. Ohmmeter shall indicate infinite resistance on highest ohms scale.	Figures FO-2, 2-21. Baseband/Diphase select relay IA1A7K4 energized.
16	Connect ohmmeter, between J4-L and J9-F. Ohmmeter shall indicate less than 1 ohm.	
17	Connect ohmmeter, between J9-H and chassis ground. Meter shall indicate less than 1 ohm.	
18	Remove +9 vdc from J4-M. Verify measurements of test numbers 15, 16, and 17. Turn off control monitor power switch and return to on. Verify test 14 indication has returned.	

Change 1 3-32A/(3-32B blank)

Table 3-16. Radio 2 Position, Secure Transmit Signal Tests and Measurements (Cont)

Test No.	Procedure	Troubleshooting Figure. Further Tests
19 20	Adjust multimeter to measure +24 vdc. Connect multimeter between J9-G and chassis ground. Meter shall indicate applied voltage (+24 v) 0.05S vdc.	
21	Apply +9 vdc to J4-M. Meter shall indicate 0 vdc.	
22	Adjust multimeter to read ohms on lowest scale.	
23	Connect ohmmeter between J9-J and chassis ground. Meter shall indicate less than 1 ohm.	
24	Turn off control monitor power switch and return to on. Ohmmeter shall indicate one megohm or greater.	

Change 1 3-33

Table 3-17. Radio 3 Position, Secure Transmit Signal Tests and Measurements (Cont)

Equipment Required:

**Audio Oscillator TS-421/U
Multimeter AN/ASM-223
Resistive adapter pad (1000:1)
as shown in figure 3-2**

Test No.	Procedure	Troubleshooting Figure. Further Tests
1	<p>Test Conditions:</p> <p>a. Radios disconnected.</p> <p>b. Security equipment disconnected.</p> <p>c. Storage Battery BB-451/U on suitable power supply connected to J1-B(+) and J1-A(-).</p> <p>Set RADIO 3 XMT-OFF-MON switch to XMT. Set RADIO 1 and RADIO 2 XMT-OFF-MON switch to OFF.</p>	
2	Set XMT MODE to SECURE RADIO 3.	Audio switching and attenuation test. Figures 2-15, 2-16.
3	Ground J11-M.	
4	Adjust oscillator to deliver a frequency of 1 KHz + 100 Hz at an output level of 0.6 + 0.1 vrms.	
5	Connect the oscillator through the 1000:1 resistor pad (see figure 3-2) to the HEADSET MIC connector as follows: J13-D (high) and J13-E (low).	
6	Adjust multimeter to read 1.0 vrms.	
7	Connect multimeter between J6-E (high) and J10-H (low). Meter shall indicate 2.7 + 0.9 mvrms.	
8	Remove ground from J11-M. Meter shall indicate 0.4 + 0.5 vrms.	
9	Remove oscillator from HDST MIC connector.	
10	Adjust multimeter to read ohms on the lowest scale.	Keying circuit test. Figures 2-19, FO-2.

Table 3-17. Radio 3 Position, Secure Transmit Signal Tests and Measurements (Cont)

Test No.	Procedure	Troubleshooting Figure. Further Tests
11	Measure continuity between J10-D and ground with J13-C grounded. Meter shall indicate less than 1 ohm. Remove J13-C ground and meter shall indicate 1 megohm or greater.	
12	Connect ohmmeter (-) lead to JS-H and (+) lead to J11-K. Meter shall indicate infinite resistance.	Measures diodes 1A7CR16, IA1CR4. (a front-to-back ratio of at least 1000:1 is normal)
13	Reverse ohmmeter leads. Meter shall measure diode front-to-back ratio.	
14	Connect ohmmeter to JS-L and J111-H. Meter shall indicate less than 1ohm.	Baseband/Diphase select test.
15	Apply +9 vdc to JS-M. Ohmmeter shall indicate infinite resistance on highest ohms scale.	Figures FO-2, 2-21. Baseband/Diphase select relay IAIA7K7 energized.
16	Connect ohmmeter between J5-L and J11-F. Ohmmeter shall indicate less than 1 ohm.	
17	Connect ohmmeter between J11-H and chassis ground. Meter shall indicate less than 1 ohm.	
18	Remove +9 vdc from J5-M. Verify measurements of tests 15,16, and	
17	Turn off control monitor power switch and return to on. Verify test 14 indication has returned.	
19	Adjust multimeter to measure +24 vdc.	
20	Connect multimeter between J11-G and chassis ground. Meter shall indicate applied voltage (+24 v) 0.05 vdc.	
21	Apply +9 vdc to JS-M. Meter shall indicate 0 vdc.	
22	Adjust multimeter to read ohms on lowest scale.	

Table 3-17. Radio 3 Position, Secure Transmit Signal Tests and Measurements (Cont)

Test No.	Procedure	Troubleshooting Figure. Further Tests
23	Connect ohmmeter between J11-J and chassis ground. Meter shall indicate less than 1 ohm.	
24	Remove +9 vdc from J5-M. Ohmmeter shall indicate less than 1 ohm.	
25	Turn off control monitor power switch and return to on. Ohmmeter shall indicate one megohm or greater.	

Change 1 3-36

Table 3-18. Power output Tests

	<p>Equipment required: Wattmeter (thru-line)</p> <p style="text-align: center;"><u>Procedure</u></p> <p>Test conditions: The facility should be connected for operation as shown in FO-1. Input voltage must be 24+, - 1.0 vdc. Tests are performed at room ambient temperature.</p>
<p>1</p> <p>2</p> <p>3</p> <p>4</p> <p>5</p> <p>6</p> <p>7</p>	<p>Connect the wattmeter between Radio 1 or 2 or 3 and the RF choke.</p> <p>Make sure that the antenna is at least 15 feet from any fixed mass, such as a wall, bridge, vehicle, tree, or any other object that might cause reflections and mismatch.</p> <p>Set RADIO 1, 2, 3 CIRCUIT BREAKERS to ON.</p> <p>Set Control Monitor POWER-OFF-ON switch to ON.</p> <p>Set RADIO 1, or 2, or 3 XDT-OFF-MON switch to XMT.</p> <p>Key the radio. The wattmeter shall indicate 4.0 watts minimum.</p> <p>Repeat test for all radios.</p>

Change 1 3-36A/ (3-36B blank)

Table 3-19. Wind Speed Circuit Tests

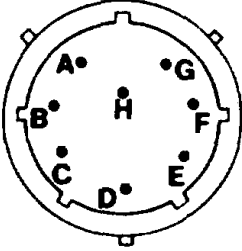
Test No.	Procedure	Troubleshooting Figure. Further Tests
1	<p>Test conditions:</p> <p>a. Cable W401 not connected to A9J12.</p> <p>b. Storage Battery BB-451/U or suitable power supply connected between 1A9J1-B(+) and 1A9JI-A(-).</p> <p>c. Control Monitor POWER-OFF-ON switch set to ON.</p> <p>Apply 5.22 vdc between 1A1A9A1J12-B(+) and 1AA9A1J12-C(-). The WIND SPEED meter shall indicate ± 1.0 knots. If correct results are not obtained adjust resistor 1A7R12 (on control board) for correct indication.</p>	<p>Figure 2-22.</p> 
2	<p>Lower input voltage to 0.260 vdc. The WIND SPEED meter shall indicate 2.0 ± 1.0 knots.</p>	
3	<p>Increase input voltage to 6.52 vdc. The WIND SPEED meter shall indicate 50.0 ± 1.0 knots.</p>	
4	<p>Disconnect voltage applied to 1A1A9A1J12.</p>	
5	<p>Connect W401, RF choke and W402 to 1A1A9A1J12 as shown in figure 2-22.</p>	
6	<p>Apply 5.22 vdc between cable W401P1-B(+) and W401-C(-). The WIND SPEED indication shall be 40.0 ± 1.0 knots. Disconnect voltage.</p>	
7	<p>Connect W401P1 to the ML-653/TSQ-97. With the impeller rotating (ccw), the WIND SPEED meter shall show some indication.</p>	

3-7. Wind Direction Signal Tests and Measurements. Perform these tests as follows:

- a. Storage Battery BB-451/U or suitable power supply connected between POWER IN connectors A9J1-B(+) and A9J1-A(-).
- b. POWER OFF-ON switch set to ON.
- c. Wind Direction and Speed Detector and cables connected as shown in figure 2-22.
- d. PUSH TO OPERATE switch pressed down (light on).
- e. Rotate the wind direction vane through 360 degrees of movement. WIND DIRECTION indicator. The indication shall track the position of the vane within + 5.0 degrees.

3-8. Transmit Control and Audio Disable Tests and Measurements (NORM). See table 3-20. When a chassis ground is applied to HDST/MIC connector J13-C, diodes on the control and interface boards route the ground (transmit control, or key) to the individual radio connectors.

Keying is routed only to radios in XMT operation with the XMT MODE switch set to NORM. In X-mode, the ground is routed to the speech security equipment and then back to the control monitor for application to the radios. Keying a radio also energizes audio disable relays to short to ground the audio from any radios not in XMT operation, leaving audible only the audio (sidetone) from the keyed radio(s). Proper operation of the audio disable relays is verified by applying 3.0 vrms at 1KHz to receive audio in J3-D (radio 1), J4-D (radio 2), and J5-D (radio 3), simultaneously or separately, and applying the keying ground under all applicable combinations of the X4MT-OFF-MODN switches and observe the observing the presence of audio from the radio position(s) in transmit (XMT) mode. To determine that the keyline diodes function requires that +30 volts dc be applied through a 10K ohm resistor simultaneously or individually (for each measurement) to J3-H, J4-H and JS-H. A keyed line is indicated when the voltage measured with the AN/USM-223 meter at J3-H, J4-H and JS-H is about 2 vdc. An indication of about +30 volts indicates the line is not keyed.

Table 3-20. Transmit Control (NORM) and Audio Disable Tests and Measurements

J13-C X-GROUNDED O-NOT GROUNDED	XMT OFF MON POSITION			RECEIVE AUDIO TO SPKR/HDST			KEYLINE INDICATION (VDC approx)		
	RAD 1	RAD 2	RAD 3	RADIO 1	RADIO 2	RADIO 3	J3H	J4H	JSH
O	XMT	XMT	XMT	YES	YES	YES	30	30	30
X	XMT	MON	MON	YES	NO	NO	2	30	30
X	MON	XMT	MON	NO	YES	NO	30	2	30
X	MON	MON	XMT	NO	NO	YES	30	30	2
X	XMT	XMT	XMT	YES	YES	YES	2	2	2
X	MDN	MON	MON	YES	YES	YES	30	30	30

Section III. DIRECT SUPPORT MAINTENANCE

3-9. Scope of Maintenance. Direct support personnel are responsible for facility maintenance to the extent defined in the maintenance allocation chart. See appendix D of TM11-5895-800-12. The procedures contained herein are primarily remove/replace and disassembly, assembly guides for the maintenance items specified for DS maintenance.

3-10. 26 Vac Adjustment. After installation of a new dc to ac inverter 1A1A11, the output voltage must be verified and adjusted if required. Press PUSH TO OPERATE switch. Measure output at IAITBI-3 to -4. Adjust output control for 26 +, -.26 vac

3-11. Microphone Amplifier Adjustment. With the control monitor energized, apply a 1000 Hz \pm 100 Hz signal at 0.600 + 0.025 vrms amplitude (through the resistor pat) to the MIC/HDST connector J13-D (high) and J13-E (low). Connect the AN/ASM-223 meter between 1A1A2TB1-E (high) and 1A1A2TB1-F (low). Adjust Variable Resistor 1A1A2R3 for a meter indication of 0.4 + .04 vrms.

3-12. Wind Speed Adjustment. With the control monitor energized, apply 5.22 + .03 vdc between A9AIJ12-B(+) and A9A1J12-C (-). Adjust resistor 1A1A7R12 for a WIND SPEED indication of 40 knots. See figure 2-22.

3-13. Remove and Replace Procedures. Refer to paragraphs 3-14 through 3-26 for individual components removal and replacement procedures.

NOTE

Apply varnish MIL-V-173 to all exposed solder joints after repairs are made.

3-14. Interior Access. To gain access to the interior of the control monitor, loosen the eight wing fasteners on the rear panel and lower the panel. Figure 3-1 shows the interior view of the facility.

3-15. Replacing Plug-In Cards. Loosen the wing fasteners on the card enclosure (fig. 3-1) cover, and remove the cover to expose the plug-in cards. Use the hook portion of the cover to pull the circuit cards out of the housing. The connector receptacles on the enclosure mother board are arranged so that the modules cannot be plugged into the wrong location.

CAUTION

The pins of the connector plugs are easily bent; use care when inserting the card. Do not force the module.

3-16. Replacing Control Board Assembly 1A1A7. Remove four screws, lock washers, and flat washers that secure the control board to the interface board. Disconnect connector A7W3P1 from 1A1A8W1J4. Carefully unplug the control board from the interface board. Remove the screw from the cable clamp and remove the 1A1A7 assembly. Forward the defective circuit board to Depot level maintenance for repair and recertification.

3-17. Replacing Interface Assembly 1A1A9A1. The interface board is fastened to the rear panel by the connectors which are installed on the assembly. The connectors pass through holes in the rear panel and are held in place by nuts threaded onto the connectors. Remove the control board 1A1A7 as outlined above. Tag location of white wires connected to E1-E14 terminals. Unsolder the fourteen wires from the terminals. Remove 10 connector nuts. The interface board can now be removed. When installing the interface assembly, the fourteen white wires must be soldered to E1-E14.

3-18. Replacing Filter 1A1A9FL1. Remove 10 screws and washers from the cover assembly. Remove cover.

Unsolder wire at terminals 1 and 2 of FL1. Remove nuts, flat washers, and lock washers, in six places. Remove filter. Install filter and hardware.

Make sure that two ground lugs are secured as before. Solder two wires previously removed. Install cover and retaining hardware.

3-18A. Replacing Relay Board 1A1A12. The wiring between 1A1A12 and interface board 1A1A9A1 is part of the 1A1A12 assembly. Unsolder the ten wires from ten terminals (E5 thru E14) of 1A1A9A1. Tag locations of the white wires. Remove screws, washers, and nuts holding the relay board assembly to the front panel. The relay board can now be removed. When installing the relay board, utilize the previously tagged wires. If another relay board is to be installed, consult schematic figure FO-2.

3-19. Replacing Power Supply Assembly 1A1A11PS1. Tag all wires to identify terminations prior to unsoldering wires. Unsolder five wires. Remove screw, lock washer and flat washer, in four places. Install replacement power supply. Secure power supply with previously removed hardware. Solder connections to new power supply pins as indicated on tags. See figure FO-2 and make continuity measurements to verify installation, prior to application of power.

3-19A. Replacing Filter 1A1FL1. The wiring between 1A1FL1 and power supply assembly 1A1A11 is part of the 1A1A11 assembly. Tag location of the wires adjacent to FL1. Unsolder the six wires from the six FL1 terminals. Remove screws and washers holding FL1 to the top of the control monitor. The filter can now be removed. When installing the filter, utilize the previously tagged wires.

3-20. Replacing Front Panel Parts. Parts mounted on the interior side of the front panel are accessible only when

the front panel is removed. Figure 3-3 shows the mounting configuration of front panel parts.

- a. Loosen 8 wing fasteners and lower rear panel.
- b. Disconnect A7W3p1 from A8W1J4 (Connects control board A7 to front panel wiring harness.)
- c. Disconnect 1A1A1A1W2P1 from A8W1J3 (connects card enclosure to front panel wiring harness).
- d. Disconnect 1A1A9W1P1 from A8W1J1 (connects to rear panel circuit breakers).
- e. At terminal board 1A1TB1, use suitable means to mark six wires (part of 1A1A8W1) for later re-termination. Remove hardware and disconnect six wires.
- f. Loosen 12 flat head screws. Remove front panel assembly 1A1A8.

3-21. Replacing Wind Direction Indicator IDI. Loosen 8 rear panel wing fasteners. Lower rear panel. Disconnect connector at rear of indicator. Remove screw attaching ground lug to altimeter case. Remove two screws attaching lights to top of indicator. Separate lights from meter. Remove three screws from indicator rim and remove indicator. Forward IDI to depot maintenance for repair.

3-22. Replacing WIND SPEED Meter. Tag location of wires connected on rear of meter. Remove three screws, washers and nuts. Meter M1 can now be removed from the panel. Discard defective meter. The wire to be connected to the (-) side of the meter terminates at 1A1A8W1J4-q.

3-23. Replacing Altimeter. Remove three cross-point recessed head screws, washers and nuts. Pull altimeter out of front panel. Forward defective altimeter to depot maintenance. Note, when installing new altimeter, the flat washer goes on the back side of the panel.

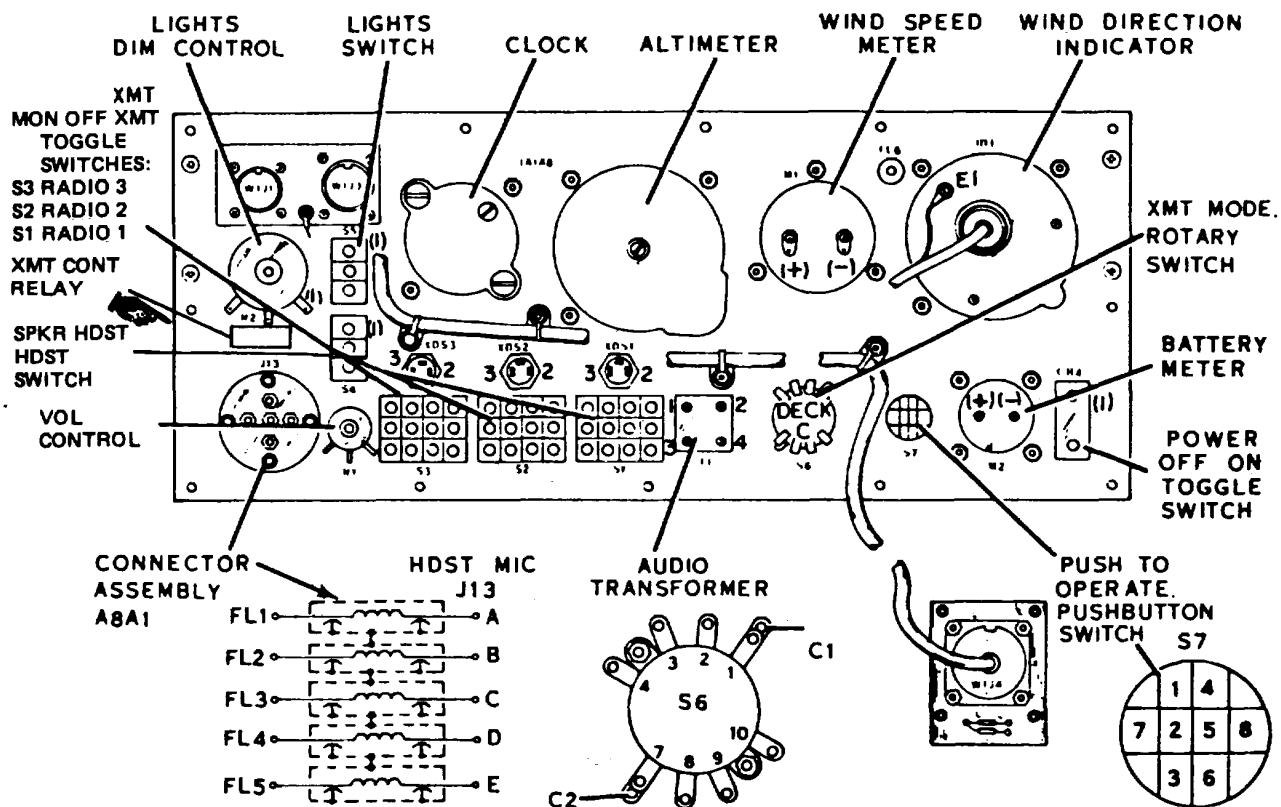

ELOST 027

Figure 3-3. Control Monitor Front Panel Parts, Mounting Configuration, Rear View

3-24. Replacing Clock. Remove three cross-point recessed head screws, washers, and nuts. Remove and discard faulty clock. Forward defective clock to depot maintenance for disposal.

NOTE

After assembly to panel, apply a fillet of adhesive MIL-A-46146 Type I, gray around the perimeter of the instrument, on the interior side of the front panel.

3-25. Replacing BATTERY Meter. Unsolder two wires from the back of the meter. Remove four screws, washers and nuts. Remove and discard meter. For reassembly the wire to be connected to the (-) negative side of the meter is the one connected to chassis ground.

3-26. Replacing SPKR-HDST Switch 1A1A8S4. Tag wires prior to removal. Remove terminal screws and wires. Remove nut and washer that attach switch to front panel.

3-27. RADIO 1, 2, 3 Circuit Breakers. To remove CB1, CB2 or CB3 first suitably tag the wires to identify connection locations. Unsolder the wires from the circuit breaker to be changed. Remove the nut and washer that attach the circuit breaker to rear panel. Install new circuit breaker with index tab on switch in locator hole on rear panel. Solder wires to circuit breaker.

3-28. POWER OFF-ON Switch/Circuit Breaker CB4. Using any suitable means mark wire branches to designate which switch terminal the wires connect to. Unsolder seven wires from CB4-1. Unsolder two wires from CB4-2. Remove nut and washer that attach the switch to the front panel. Remove and discard defective CB4. Install replacement switch with terminal designated 2, towards the lower edge of the panel.

3-29. Audio Transformer 1A1A8T1 Mark wires to identify terminations. Unsolder four wires. Remove two screws that attach the transformer to the front panel. Install replacement transformer with terminal 1 adjacent to the upper edge of the RADIO 1 XNT OFF MON switch. Install securing hardware and solder wires to respective terminals. Verify connections prior to application of power:

From 1A1A8T1-4 to 1A1TB1-6
 From 1A1A8T1-3 to 1A1TB1-5
 From 1A1A8T1-2 to Chassis ground
 From 1A1A8T1-1 to HDST/SPKR HDST

3-30. Lights MON-ON-ON Switch 1A1A8S5. Tag wires prior to removing them. Remove terminal screws and wires. Remove nut and washer that attach switch to front panel.

3-31. DIM Control 1A1A8R2. Tag wires prior to removal. Loosen set screw and remove knob. Unsolder wires from

1A1A8R2. Remove nut and washer that attach the DIM control to the front panel.

3-32. VOL Control 1A1A8R1 Tag wires prior to removal. Loosen set screw and remove control knob. Unsolder wires from 1A1A8R11. Remove nut and washer that attach the control to the front panel.

3-33. AUDIO Indicators 1A1A8XDS 1, 2, 3. Tag wires prior to removal. Unsolder attached wires. Remove hardware that attaches the part to the front panel.

3-34. XMT-OFF-MON Switches 1A1A8S 1, 2, 3. Remove nut and washer that attach switch to front panel. Remove switch from mounting hole. Mount replacement switch. Transfer wires one at a time to the replacement switch. Refer to table 3-21 to make continuity measurements to verify wiring.

3-35. PUSH TO OPERATE Switch 1A1ASS7. Remove waterproof boot and green push button. Unscrew threaded adapter (nut) that fastens switch to panel. Remove defective switch. Install replacement switch. Adjust rear nut and threaded adapter for proper switch action when the weatherproof boot and push button are installed. Transfer wires from switch terminals to like terminals on newly installed switch.

3-36. XMT-MODE Switch 1A1A8S6. This is 5 a three-deck rotary switch. The deck switch 1A1A8S4-2 nearest the panel is designated deck A.

Each deck consists of two common connections (wipers C1, C2) and 4 associated connections per common terminal as shown in figure 3-4. To remove the switch loosen set screw and remove control knob. Remove nut that fastens switch to panel. When installing the switch make sure that the rubber gasket is seated in the groove on the fixed nut on the

Table 3-21. Wiring Chart for XMT-OFF-MON Switches

FROM 1A1A8S TERM. NO.	TO	FROM 1A1A8S2 TERM. NO.	TO	FROM 1A1A8S3 TERM. NO.	TO
1-3	No Connections	1-3	No Connections	1-3	No Connections
4	1A1A8S1-6	4	LA1A8S2-6	4	1A1A8S3-6
5	W1J4-v	5	W1J4-x	5	W1J4-u
6	1A1A8S1-4, W1J3-A	6	1A1A8S2-4, W1J3-H	6	1A1A8S3-4, W1J3-J
7	No Connection	7	No Connection	7	No Connection
8	E7, W1J4-T	8	1A1A8S6B-7, W1J4-R	8	E6, W1J4-H
9	W1J4-s	9	W1J4-U	9	W1J4-J
10	No Connection	10	No Connection	10	No Connection
11	W1J4-W	11	W1J4-N		11 W1J4-B
12	W1J4-d	12	W1J4-M		12 W1J4-E

threaded shaft. Make sure that the keyway washer is installed on the threaded shaft so that it will fit into the index hole on the panel when the switch is installed. It may be necessary to trim some length off the locator tab of the keyway washer if it bottoms in the index hole. If the keyway washer from the original switch is serviceable it may be used in lieu of the one furnished with the new switch.

a. *Switch Wiring.* Tag wires prior to unsoldering them. The wires may be transferred one at a time if so desired.

b Refer to table 3-22 for wiring information. After the switch is wired perform continuity tests to confirm wiring, prior to application of power.

3-36A. Keying Relay 1A1A8K1. Unsolder and tag relay in accordance with pin location of six wires from 1A1A8K1. Unsolder 1A1A8C1 noting polarity to relay pins. Remove the capacitor by cutting or prying from the soft adhesive compound. Remove two sets of screws, washers, and nuts holding relay to the front panel. The relay can now be removed. Resolder wires using new sleeving and capacitor (noting correct polarity) to the new relay. Position capacitor on top of relay as originally located. Shrink sleeving to terminals and form leads away from mounting surface of the relay. Use adhesive, MIL-A-46146, Type I, Gray to secure capacitor to relay and insulate between terminals. Install relay with previously removed hardware. Consult schematic figure FO-2 during installation.

Table 3-22. Wiring Chart for XMT-MODE Switch

From	To	From	To
S6A-C1	J4-BB	S6B-C1	S6A-7
S6A-C2	K1-N	S6B-C2	S6B-C1
S6A-2	J4-X	S6B-1	ES
S6A-3	J4-P	S6B-7	S2-8
S6A-4	J4-A	S6C-C1	S5-2
S6A-8	J4-k	S6C-C1	J4-t
S6A-9	J4-Y	S6C-C2	K1-B2
S6A-10	J4-C	S6C-2	J4-V
		S6C-3	J4-C
		S6C-4	J4-D
		S6C-8	J4-Z
		S6C-9	J4-L
		S6C-10	J4-G

Change 1 3-44

Section IV. DIRECT SUPPORT PERFORMANCE STANDARD TESTING PROCEDURES

3-37. General. Direct support testing procedures are to be performed on the AN/TSQ-97 after the equipment has been repaired. The objective of performing the tests is to verify satisfactory performance prior to returning the equipment to the user. In order to produce reliable repeatable results, the procedures must be followed in the order given and all controls must be set accurately. If the equipment fails to pass a test, refer to Troubleshooting, Section II. Troubleshoot and repair. After repair, the entire test must be repeated. After repair, when preparing the facility for return to the user, observe the following warning:

WARNING
Do not seal activated batteries in airtight containers such as transit cases, as hydrogen out-gassing

may create an explosive environment. Transport the battery separately.

3-38. Test Procedures. The test procedures are separated into the following functional categories:

- a. Power distribution. Table 3-23
- b. Receive audio (clear). Table 3-24
- c. Receive X-mode signal. Table 3-25
- d. Transmit audio (clear). Table 3-26
- e....Transmit X-mode signal. Table 3-27
- f....Wind direction wind speed. Table 3-19

Table 3-23. Power Distribution, Performance Standard, Test Procedures

Step	Control Settings		Procedure	Performance Standard
	Test Equipment	Control Monitor		
1	Multimeter AN/USM-223 on 30 vdc scale.	a. POWER-ON-OFF switch OFF. RADIO 1 circuit breaker OFF.	<p><u>Note. The following tests are made with all cables disconnected from the rear panel of the AN/TSQ-97 with the exception of the power cable supplying 24 vdc to connector J1.</u></p> <p>Connect Multimeter AN/USM-223 high to connector J3, pin A and low to connector J3, pin V.</p>	Multimeter AN/USM-223 should indicate 0 ± 100 mvdc.

Table 3-23. Power Distribution, Performance Standard, Test Procedures (Cont)

Step	Control Settings		Procedure	Performance Standard
	Test Equipment	Control Monitor		
2		b. RADIO 1 circuit breaker ON.	should indicate	AN/USM-223
3		c. POWER-ON-OFF switch ON.	should indicate	0 + 100 mvdc. AN/USM-223
4		a. POWER-ON-OFF switch OFF. RADIO 2 circuit breaker OFF.	24 + 2.5 vdc. Connect AN/USH-223 high to connector J4, pin A and low to connector J4, pin V.	AN/USM-223 should indicate 0 + 100 mvdc.
5		b. RADIO 2 circuit breaker ON.	AN/USM-223 should indicate	0 + 100 mvdc.
6		c. POWER-I-OFF switch ON. 24 + 2.5 vdc.	AN/USM-223 should indicate	
7		a. POWER-ON-OFF switch OFF. RADIO 3 circuit breaker OFF.	Connect AN/USM-223 high to connector JS, pin A and low to connector J5, pin V.	AN/USM-223 should indicate 0 + 100 mvdc.
8		b. RADIO 3 circuit breaker ON.	AN/USM-223 should indicate	0 + 100 mvdc.
9		c. POWER-ON-OFF switch ON.	24 + 2.5 vdc.	AN/USM-223 should indicate
10			Observe BATTERY meter. indicate 24 + 2.5 vdc.	Meter should
11	AN/USM-223 on 30 vac scale.		Connect AN/USM-223 to connector J12, pins D and G and push WIND DIRECTION PUSH TO OPERATE switch. 3-46	AN/USM-223 should indicate 26 + 0.5 vac.

Table 3-23. Power Distribution, Performance Standard, Test Procedures (Cont)

Step	Control Settings		Procedure	Performance Standard
	Test Equipment	Equipment Under Test		
12			PUSH WIND DIRECTION PUSH TO OPERATE switch.	AN/USM-223 should indicate 0 ± 100 mvac.
13		a. LIGHTS ON- OFF, MON-ON switch ON. b. DIM control fully clock- wise.	Observe flexible-shaft lamp and WIND DIRECTION lamps.	Lamps should be lit. Maximum lamp brightness.
14		DIM control fully counter- clockwise.	Observe flexible-shaft lamp and WIND DIRECTION lamps.	Lamps should be dim.
15	AN/USM-223 on 30 vdc scale.	DIM control fully clock- wise.	Connect AN/USM-223 high to connector J3, pin G and low to connector J3, pin V.	AN/USM-223 should indicate 24 vdc.
16		DIM control fully counter- clockwise.		AN/USM-223 should indicate 18.5 ± 1.0 vdc.
17		DIM control fully clock- wise.	Connect AN/USM-223 high to connector J4, pin G and low to connector J4, pin V.	AN/USM-223 should indicate 24 ± 25 vdc.
18		DIM control fully counter- clockwise.		AN/USM-223 should indicate 18.5 ± 1.0 vdc.
19		DIM control fully clock- wise.	Connect AN/USM-223 high to connector J5, pin G and low to connector JS, pin V.	AN/USM-223 should indicate 24 ± 2.5 vdc.
20		DIM control fully counter- clockwise.		AN/USM-223 should indicate 18.5 ± 1.0 vdc.

Table 3-24. Receive Audio (Clear), Performance Standard Test Procedures

1-15 RADIO 1, 16-21 RADIO 2

Step	Control Settings		Procedure	Performance Standard
	Test Equipment	Equipment Under Test		
1			Apply +24 +, -2.5 vdc to J1-B(+) and J1-A(-)	
2		Control Monitor POWER OFF-ON switch to ON.		
3	XMT-MODE switch to NORM.			
4	Control Monitor VOL control to maximum cw.			
5	Control Monitor SPKR-HDST-HDST switch to HDST/SPKR.			
6	TS-421/U Oscillator set to deliver a 1000 Hz signal at a level of 3.0 +, -0.100 vrms.		Apply a 1000 Hz signal at 3.0 vrms to J3-D (high) to J3-E (low).	
7	AN/USM-223 to measure 2 vrms,		Connect AN/USM-223, between J13-B and J13-A.	
8	Set AN/USM-281 Oscilloscope to measure about 3Vp-p.		Connect oscilloscope between 1A1ATB1-5 and 1A1TB1-6.	

Table 3-24. Receive Audio (Clear), Performance Standard Test Procedures (Cont)

Step	Control Settings		Procedure	Performance Standard
	Test Equipment	Equipment Under Test		
9		Set XMT-OFF-MON switches to OFF.		<ul style="list-style-type: none"> a. Only RADIO 1 AUDIO indicator lit. b. Oscilloscope indicates no voltage. c. Meter indicates no voltage.
10		Set XMT-OFF-MON switches to MON.		<ul style="list-style-type: none"> a. Meter indicates 2.0 vrms minimum. b. Oscilloscope indicates 2.1 Vp-p minimum. c. Only RADIO 1 AUDIO indicator lit.
11		Set RADIO 1 XMT-OFF-MON switch to XMT. Set to OFF for RADIO 2 and RADIO 3.		<ul style="list-style-type: none"> a. Meter shall indicate 2.0 vrms minimum. b. Oscilloscope shall indicate 2.1 Vp-p minimum. c. Only RADIO 1 AUDIO lit.
12		<ul style="list-style-type: none"> a. Set RADIO 1 and RADIO 3 XMT-OFF-MON switches to OFF. For RADIO 2 set to XMT. b. Set Control Monitor SPKR-HDST-HDST switch to HDST. 		<ul style="list-style-type: none"> a. Meter shall indicate no voltage. b. Oscilloscope indicates no voltage. c. Only RADIO 1 AUDIO indicator lit.

Table 3-24. Receive Audio (Clear), Performance Standard Test Procedures (Cont)

Step	Control Settings		Procedure	Performance Standard
	Test Equipment	Equipment Under Test		
13		Set RADIO 1 and RADIO 2 XMT-OFF-MON switches to OFF. For RADIO 3 set to XMT.		<ul style="list-style-type: none"> a. Meter shall indicate no voltage. b. Oscilloscope shall indicate no voltage. c. Only RADIO 1 AUDIO indicator lit.
14		Set RADIO 1, RADIO 2, RADIO 3 XMT-OFF-MON switches to XMT.		<ul style="list-style-type: none"> a. Meter shall indicate 2.0 vrms minimum. b. Oscilloscope shall indicate no voltage. c. Only RADIO 1 AUDIO indicator lamp lit.
15		Set RADIO 1, RADIO 2, and RADIO 3 XMT-OFF-MON switches to MON.		<ul style="list-style-type: none"> a. Meter shall indicate 2.0 vrms minimum. b. Oscilloscope shall indicate no voltage. c. Only RADIO 1 AUDIO indicator lamp lit.
16	Oscillator set to 1000 Hz at 3.0 ± 0.100 vrms.	Set SPKR-HDST-HDST switch to SPKR/HDST.	Remove signal generator from J3. Apply signal to J4-D (high) to J4-E (low).	<ul style="list-style-type: none"> a. Only RADIO 2 AUDIO indicator lit. b. Meter shall indicate 2.0 vrms minimum. c. Oscilloscope shall indicate 2.1 Vp-p minimum.

Table 3-24. Receive Audio (Clear), Performance Standard Test Procedures (Cont)

Step	Control Settings		Procedure	Performance Standard
	Test Equipment	Equipment Under Test		
17		Set RADIO 1 XMT-OFF-MON switch to XMT. For RADIO 2 and RADIO 3 set to OFF.		<ul style="list-style-type: none"> a. Meter shall indicate no voltage. b. Oscilloscope shall indicate no voltage. c. Only RADIO 2 AUDIO indicator lit.
18		<ul style="list-style-type: none"> a. Set RADIO 1 and RADIO 3 XMT-OFF-MON switches to OFF. Set RADIO 2 XMT-OFF-MON switch to XMT. b. Set SPKR-HDST-HDST switch to HDST. 		<ul style="list-style-type: none"> a. Meter shall indicate 2.0 vrms minimum. b. Oscilloscope shall indicate no voltage. c. Only RADIO 2 AUDIO indicator lit.
19		Set RADIO 1 and 2 XMT-OFF-MON switches to OFF. Set RADIO 3 XMT-OFF-MON switch to XMT.		<ul style="list-style-type: none"> a. Meter shall indicate no voltage. b. Oscilloscope shall indicate no voltage. c. RADIO 2 AUDIO indicator lit.

Table 3-24. Receive Audio (Clear), Performance Standard Test Procedures (Cont)

Step	Control Settings		Procedure	Performance Standard
	Test Equipment	Equipment Under Test		
20		Set XMT-OFF-MON switches to XMT.		<ul style="list-style-type: none"> a. Meter shall indicate 2.0 vrms minimum. b. Oscilloscope shall indicate no voltage. c. Only RADIO 2 AUDIO indicator lit.
21		Set XMT-OFF-MON switches to MON.		<ul style="list-style-type: none"> a. Meter shall indicate 2.0 vrms minimum. b. Oscilloscope shall indicate no voltage. c. Only RADIO 2 AUDIO indicator lit.
22	Oscillator set to 1000 Hz at 3.0 ± 0.100 vrms.	Set SPKR-HDST-switch to SPKR/IIDST.	Remove signal generator from J4. Apply signal to JS-D (high) and J5-E (low).	<ul style="list-style-type: none"> a. Meter shall indicate 2.0 vrms minimum. b. Oscilloscope shall indicate 2.1 Vp-p minimum. c. Only RADIO 3 AUDIO indicator lit.

Table 3-24. Receive Audio (Clear), Performance Standard Test Procedures (Cont)

Step	Control Settings		Procedure	Performance Standard
	Test Equipment	Equipment Under Test		
23		Set RADIO 3 XMT-OFF-MON switch to OFF.		<ul style="list-style-type: none"> a. Meter shall indicate no voltage. b. Oscilloscope shall indicate no voltage. c. Only RADIO 3 AUDIO indicator lit.
24		Set RADIO 2 XMT-OFF-MON switch to OFF. Set to XMT for RADIO 1.		<ul style="list-style-type: none"> a. Meter shall indicate no voltage. b. Oscilloscope shall indicate no voltage. c. Only RADIO 3 AUDIO indicator lit.
25		Set RADIO 1 XMT-OFF-MON switch to OFF. For RADIO 2 set to XMT. Set SPKR-HDST-HDST switch to HDST.		<ul style="list-style-type: none"> a. The meter shall indicate no voltage. b. The oscilloscope shall indicate no voltage. c. Only RADIO 3 AUDIO indicator lit.

Table 3-24. Receive Audio (Clear), Performance Standard Test Procedures (Cont)

Step	Control Settings		Procedure	Performance Standard
	Test Equipment	Equipment Under Test		
26		Set RADIO 2 XMT-OFF-MON switch to OFF. For RADIO 3 set to XMT.		<ul style="list-style-type: none"> a. Meter shall indicate 2.0 vrms minimum. b. Oscilloscope shall indicate no voltage. c. Only RADIO 3 AUDIO indicator lit.
27		Set RADIO 1 and 2 XMT-OFF-MON switches to XMT.		<ul style="list-style-type: none"> a. Meter shall indicate 2.0 vrms minimum. b. Oscilloscope shall indicate no voltage. c. Only RADIO 3 AUDIO indicator lit.
28		Set XMT-OFF-MON switches to MON.		<ul style="list-style-type: none"> a. Meter shall indicate 2.0 vrms minimum. b. Oscilloscope indicates no voltage. c. Only RADIO 3 AUDIO indicator lit.

Table 3-25. Receive X-Mode Signal, Performance Standard Tests

1-23 RADIO 1, 24-40 RADIO 2, 41-55 RADIO 3

Step	Control Settings		Procedure	Performance Standard
	Test Equipment	Equipment Under Test		
1			Apply +24, +, -1.0 vdc to J1-B (+) and J1-A1-).	
2	TS-421/U Oscillator set to deliver 1000 Hz at a level of 2.0 vros.		Connect oscillator between J6-C (high) and J6-A (low).	
3	Adjust AN/USN-223 meter to measure about 3 vrms.		Connect meter to J13-B (high) and J13-E (low).	
4	Set Oscilloscope AN/ASM-281 to measure 0.3Vp-p minimum.		Connect oscilloscope between 1A1TB1-5 and 1A1TB1-6 (low).	
5		Set POWER-OFF-ON switch to ON.		
6		Adjust VOL control to maximum cw. Set SPKR-HDST-HDST switch to SPKR/HDST.		
7		Set XMT-OFF-MON switches to OFF.		a. Meter shall indicate no voltage. b. Oscilloscope shall indicate no voltage. c. No AUDIO indicators lit.

Table 3-25. Receive X-Mode Signal, Performance Standard Tests (Cont)

Step	Control Settings		Procedure	Performance Standard
	Test Equipment	Equipment Under Test		
8		Set XMT-OFF-MON switches to MON.		Same as for step 7.
9		Set XMT-OFF-MON switches to OFF.	a. Ground J6-F. b. Remove ground.	Same as for Step 7, except RADIO 1 AUDIO lights.
10			a. Ground J8-F. b. Remove ground.	Same as for Step 7.
11			Ground J10-F.	Same as for Step 7.
12		Set RADIO 3 XMT-OFF-MON switch to MON.		Same as for Step 7.
13		Set RADIO 2 XMT-OFF-MON switch to MON. For RADIO 3 set to OFF.	Ground J6-F, J8-F and J10-F.	a. Only RADIO 1 AUDIO indicator lights. b. No voltage indication. c. No oscilloscope indication.
14		Set RADIO 1 XMT-OFF-ON switch to MON. RADIO 2 OFF.		a. Only RADIO 1 AUDIO indicator lights. b. Meter indicates 2.0 vrms minimum. c. Oscilloscope indicates 2.1Vp-p minimum.

Table 3-25. Receive X-Mode Signal, Performance Standard Tests (Cont)

Step	Control Settings		Procedure	Performance Standard
	Test Equipment	Equipment Under Test		
15		a. Set RADIO 1 XMT-OFF-MON switch to XMT. b. Set SPKR-HDST switch to HDST.		a. Only RADIO 1 AUDIO indicator lit. b. Meter indicates 2.0 vrms minimum. c. Oscilloscope indicates no voltage.
16			a. Ground J13-C. b. Remove ground.	Same as for Step 15.
17		Set RADIO 1 and 3 XMT-OFF-MON switch to OFF. For RADIO 2 set to XMT.		a. Only RADIO 1 AUDIO indicator lit. b. Meter indicates no voltage. c. Oscilloscope indicates no voltage.
18			a. Ground J13-C. b. Remove ground.	Same as for Step 7.
19		Set RADIO 2 XMT-OFF-MON switch to OFF. For RADIO 3 set to XMT.		Same as for Step 17.
20			a. Ground J13-C. b. Remove ground.	Same as for Step 7.
21		Set XMT-OFF-MON switches to XMT.		a. Only RADIO 1 AUDIO indicator lights. b. Meter indicates 2.0 vrms minimum.

Table 3-25. Receive X-Mode Signal, Performance Standard Tests (Cont)

Step	Control Settings		Procedure	Performance Standard
	Test Equipment	Equipment Under Test		
22			Remove grounds from J6-F, J8-F, J10-F.	c. Oscilloscope indicates no voltage.
23			Remove oscillator from J6-C.	
24		Set XMT-OFF-MON switches to OFF. Set SPKR-HDST-HDST switch to SPKR/HDST.	Apply oscillator output to J8-C (high) and J8-A (low).	a. Meter and oscilloscope indicate no voltage. No AUDIO indicators lit.
25		Set XMT-OFF-MON switches to MON.		Same as for Step 24.
26		Set XMT-OFF-MON switches to OFF.	a. Ground J6-F. b. Remove ground.	Same as for Step 24.
27			a. Ground J8-F. b. Remove ground.	a. Only RADIO 2 AUDIO lit. b. Meter indicates no voltage. c. Oscilloscope indicates no voltage.
28			Ground J10-F.	Same as for Step 24.
29		Set RADIO 3 XMT-OFF-MON switch to MON.		Same as for Step 24.

Table 3-25. Receive X-Mode Signal, Performance Standard Tests (Cont)

Step	Control Settings		Procedure	Performance Standard
	Test Equipment	Equipment Under Test		
30		Set RADIO 1 and 3 XMT-OFF-MON switches to OFF. For RADIO 2 set to MON.	Ground J6-F, J8-F, J10-F.	<ul style="list-style-type: none"> a. Only RADIO 2 indicator lit. b. Meter indicates 2.0 vrms minimum. c. Oscilloscope indicates 2.1Vp-p minimum.
31		Set RADIO 1 XMT-OFF-MON switch to MON. For RADIO 2 and 3 set to OFF.		<ul style="list-style-type: none"> a. RADIO 2 AUDIO indicator lit. b. No meter indication. c. No scope indication.
32		<ul style="list-style-type: none"> a. Set SPKR-HDST-HDST switch to HDST. b. Set RADIO 1 XMT-OFF-MON switch to XMT. 		<ul style="list-style-type: none"> a. Only RADIO 2 AUDIO indicator lit. b. No meter indication. c. No scope indication.
33			<ul style="list-style-type: none"> a. Ground J13-C. b. Remove ground. 	Same as for Step 24.
34		Set RADIO 1 XMT-OFF-MON switch to OFF. For RADIO 2 set to XMT.		<ul style="list-style-type: none"> a. Only RADIO 2 AUDIO indicator lit. b. Meter indicates 2.0 vrms minimum. c. No oscilloscope indication.
35			<ul style="list-style-type: none"> a. Ground J13-C. b. Remove ground. 	Same as for Step 24.

Table 3-25. Receive X-Mode Signal, Performance Standard Tests (Cont)

Step	Control Settings		Procedure	Performance Standard
	Test Equipment	Equipment Under Test		
36		Set RADIO 2 XMT-OFF-MON switch to OFF. For RADIO 3 set to XMT.		a. RADIO 2 AUDIO indicator lit. b. No meter indication. c. No scope indication.
37			a. Ground J13-C. b. Remove ground.	Same as for Step 24.
38		Set XMT-OFF-MON switches to XMT.		a. Radio 2 AUDIO indicator lit. b. Meter indicates 2.0 vrms minimum. c. No scope indication.
39			Remove grounds from J6-F, J8-F and J10-F.	
40			Remove oscillator from J8-C.	
41	Oscillator set to 1000 Hz at 2.0 vrms.	a. Set XMT-OFF-MON switches to OFF. b. Set SPKR-HDST-HDST switch to SPKR/HDST.	Apply oscillator to J10-C (high) and J10-A (low).	a. No meter and oscilloscope indication. b. No AUDIO indicators lit.
42		Set XMT-OFF-MON switches to MON.		Same as for Step 41.
43		Set XMT-OFF-MON switches to OFF.	a. Ground J6-F. b. Remove ground.	Same as for Step 41.

Table 3-25. Receive X-Mode Signal, Performance Standard Tests (Cont)

Step	Control Settings		Procedure	Performance Standard
	Test Equipment	Equipment Under Test		
44			a. Ground J8-F. b. Remove ground.	Same as for Step 41.
45			Ground J10-F only.	a. RADIO 3 AUDIO indicator lit. b. No meter indication. c. No scope indication.
46		Set RADIO 3 XMT-OFF-MON switch to MON.		a. Only RADIO 3 AUDIO indicator lit. b. Meter indicates 2.0 ohms minimum. c. Oscilloscope indicates 2.1 Vp-p minimum.
47		Set RADIO 2 XMT-OFF-MON switch to MON. For RADIO 1 and 3 set to OFF.	Ground J6-F, J8-F and J10-F.	a. Only RADIO 3 AUDIO indicator lit. b. No meter indication. c. No scope indication.
48		Set RADIO 1 XMT-OFF-MON switch to MON. For RADIO 2 and 3 set to OFF.		a. Only RADIO 3 AUDIO indicator lit. b. No meter indication. c. No scope indication.

Table 3-25. Receive X-Mode Signal, Performance Standard Tests (Cont)

Step	Control Settings		Procedure	Performance Standard
	Test Equipment	Equipment Under Test		
49		<ul style="list-style-type: none"> a. Set SPKR-HDST-HDST switch to HDST. b. Set RADIO 1 XMT-OFF-MON switch to XMT. 		<ul style="list-style-type: none"> a. Only RADIO 1 3 AUDIO indicator lit. b. No meter indication. c. No scope indication.
50			<ul style="list-style-type: none"> a. Ground J13-C. b. Remove ground. 	Same as for Step 41.
51		Set RADIO 1 XMD-OFF-MON switch to OFF. For RADIO 2 set to XMT.		<ul style="list-style-type: none"> a. Only RADIO 1 3 AUDIO indicator lit. b. No meter indication. c. No scope indication.
52			<ul style="list-style-type: none"> a. Ground J13-C. b. Remove ground. 	Same as for Step 41.
53		Set RADIO 2 XMT-OFF-MON switch to OFF. For RADIO 3 set to XMT.		<ul style="list-style-type: none"> a. Only RADIO 1 3 AUDIO indicator lit. b. Meter indicates 2.0 vrms minimum. c. No scope indication.
54			<ul style="list-style-type: none"> a. Ground J13-C. b. Remove ground. 	Same as for Step 53.
55		Set XMT-MON switches to XMT.		Same as for Step 53.

Table 3-26. Transmit Audio (Clear), Performance Standard Test Procedures

Step	Control Settings		Procedure	Performance Standard																														
	Test Equipment	Equipment Under Test																																
1	<p>a. TS-421/U oscillator set to 0.6 ± 0.02 vrms at 1000 ± 100 Hz.</p> <p>b. AN/USM-223 meter set to measure 0.4 vrms.</p> 	<p>a. XMT-OFF-MON switches to OFF.</p> <p>b. XMT-MODE switch to NORM.</p> <p>NOTE If required for step b, adjust 1A1A2R3 to 0.40 vrms .</p> 	<p>a. Connect meter to 1A1A2TB1-E (high), 1A1A2TB1-F (low).</p> <p>b. Apply oscillator output through resistor pad (fig. 3-2) to J13-D (high) and J13-E (low).</p> <p>c. Connect meter to:</p> <table style="margin-left: 20px;"> <tr> <td><u>high</u></td> <td></td> <td><u>low</u></td> </tr> <tr> <td>J7-U</td> <td>-</td> <td>J7-E</td> </tr> <tr> <td>J9-U</td> <td>-</td> <td>J9-E</td> </tr> <tr> <td>J11-U</td> <td>-</td> <td>J11-E</td> </tr> <tr> <td>J3-K</td> <td>-</td> <td>J11-E</td> </tr> <tr> <td>J4-K</td> <td>-</td> <td>J11-E</td> </tr> <tr> <td>J5-K</td> <td>-</td> <td>J11-E</td> </tr> <tr> <td>J6-E</td> <td>-</td> <td>J11-E</td> </tr> <tr> <td>J8-E</td> <td>-</td> <td>J11-E</td> </tr> <tr> <td>J10-E</td> <td>-</td> <td>J11-E</td> </tr> </table>	<u>high</u>		<u>low</u>	J7-U	-	J7-E	J9-U	-	J9-E	J11-U	-	J11-E	J3-K	-	J11-E	J4-K	-	J11-E	J5-K	-	J11-E	J6-E	-	J11-E	J8-E	-	J11-E	J10-E	-	J11-E	<p>Meter indicates 0.40 + 0.04 -0.12 vrms.</p> <p>0.4+, 0.04 vrms.</p> <p style="text-align: right;">* * * ** ** ** ** ** **</p>
<u>high</u>		<u>low</u>																																
J7-U	-	J7-E																																
J9-U	-	J9-E																																
J11-U	-	J11-E																																
J3-K	-	J11-E																																
J4-K	-	J11-E																																
J5-K	-	J11-E																																
J6-E	-	J11-E																																
J8-E	-	J11-E																																
J10-E	-	J11-E																																
2		RADIO 1 XMT OFF to XMT,	<p>Connect meter to:</p> <table style="margin-left: 20px;"> <tr> <td><u>high</u></td> <td></td> <td><u>low</u></td> </tr> <tr> <td>J3-K</td> <td>-</td> <td>J3-E</td> </tr> <tr> <td>J7-U</td> <td>-</td> <td>J7-E</td> </tr> <tr> <td>J9-U</td> <td>-</td> <td>J9-E</td> </tr> <tr> <td>J11-U</td> <td>-</td> <td>J11-E</td> </tr> <tr> <td>J4-K</td> <td>-</td> <td>J11-E</td> </tr> </table> <p style="margin-left: 40px;">+0.04</p> <p>Key: *0.40 vrms -0.12</p> <p>** = no voltage</p>	<u>high</u>		<u>low</u>	J3-K	-	J3-E	J7-U	-	J7-E	J9-U	-	J9-E	J11-U	-	J11-E	J4-K	-	J11-E	<p style="text-align: right;">* * * * **</p>												
<u>high</u>		<u>low</u>																																
J3-K	-	J3-E																																
J7-U	-	J7-E																																
J9-U	-	J9-E																																
J11-U	-	J11-E																																
J4-K	-	J11-E																																

Table 3-26. Transmit Audio (Clear), Performance Standard test Procedures (Cont)

Step	Control Settings		Procedure	Performance Standard
	Test Equipment	Equipment Under Test		
2 (Cont)			J5-K - J11-E J6-E - J11-E J8-E - J11-E J10-E - J11-E	** ** ** **
3		Set RADIO 1 XMT-OFF-MON to OFF, for RADIO 2, set to XMT.	Connect meter to: <u>high</u> <u>low</u> J4-K - J4-E J7-U - J7-E J9-U - J9-E J11-U - J11-E J3-K - J11-E J5-K - J11-E J6-E - J11-E J8-E - J11-E J10-E - J11-E	* * * * ** ** ** ** ** **
4		Set RADIO 2 XMT-OFF-MDN to OFF. For RADIO 3 set to XMT.	Connect meter to: <u>high</u> <u>low</u> J5-K - J5-E J7-U - J7-E J9-U - J9-E J11-U - J11-E J3-K - J11-E J4-K - J11-E J6-E - J11-E J8-E - J11-E J10-E - J11-E	* * * * ** ** ** ** ** **
5		RADIO 2 XMT OFF MON to XMT.	Connect meter to: <u>high</u> <u>low</u> J4-K - J4-E J5-K - J5-E J7-U - J7-E	

+0.04
Key: *0.40 vrms
 -0.12
 ** = no voltage

Table 3-26. Transmit Audio (Clear), Performance Standard Test Procedures (Cont)

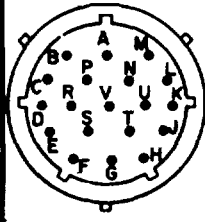
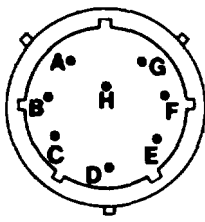
Step	Control Settings		Procedure	Performance Standard
	Test Equipment	Equipment Under Test		
5 (Cont)			J9-U - J9-E J11-U - J11-E J3-K - J11-E J6-E - J11-E J8-E - J11-E J10-E - J11-E	* * ** ** ** **
6		RADIO 1 XMT-OFF MON to XMT.	Connect meter to: high low J3-K - J3-E J4-K - J4-E J5-K - J5-E J7-U - J7-E J9-U - J9-E J11-U - J11-E J6-E - J11-E J8-E - J11-E J10-E - J11-E	* * * * * * ** ** ** **
7		Set all XMD-OFF- MON switches to MON	Connect meter to: <u>high</u> <u>low</u> J7-U - J7-E J9-U - J9-E J11-U - J11-E J3-K - J11-E J4-K - J11-E J5-K - J11-E J6-E - J11-E J8-E - J11-E J10-E - J11-E	* * * ** ** ** ** ** ** **

*0.40
Key: 0.04 vrms
 -0.12
** = no voltage

Table 3-26. Transmit Audio (Clear), Performance Standard Test Procedures (Cont)

Step	Control Settings		Procedure	Performance Standard
	Test Equipment	Equipment Under Test		
8		RADIO 1 XMT-OFF-MON to XMT	Connect meter to: <u>high</u> <u>low</u> J3-K - J3-E J7-U - J7-E J9-U - J9-E J11-U - J11-E J4-K - J11-E J5-K - J11-E J6-E - J11-E J8-E - J11-E J10-E - J11-E	* * * * ** ** ** ** **
9		RADIO 1 XMT-OFF-MON to MON. For RADIO 2 set to	Connect meter to: <u>high</u> <u>low</u> J4-K - J4-E J7-U - J7-E J9-U - J9-E J11-U - J11-E J3-K - J3-E J5-K - J5-E J6-E - J5-E J8-E - J5-E J10-E - J5-E	* * * * ** ** ** ** **
10		RADIO 2 XMT-OFF-MON to MON. For RADIO 3 set to XMT.	Connect meter to: <u>high</u> <u>low</u> J5-K - J5-E J7-U - J7-E J9-U - J9-E J11-U - J11-E J3-K - J11-E J4-K - J11-E J6-E - J11-E J8-E - J11-E J10-E - J11-E	* * * * ** ** ** ** **

+0.04
 Key: *0.40 vrms
 -0.12
 ** = no voltage

Table 3-26. Transmit Audio (Clear), Performance Standard Test Procedures (Cont)

Step	Control Settings		Procedure	Performance Standard
	Test Equipment	Equipment Under Test		
11		<p>RADIO 2 and 3 XMT- OFF-MON switches to XMT.</p> <p>Set RADIO 3 XMT- OFF-MON to MON</p>	<p>Connect meter to:</p> <p><u>high</u> <u>low</u></p> <p>J4-K - J4-E J5-K - J5-E J7-U - J7-E J9-U - J9-E J11-U - J11-E J3-K - J11-E J6-E - J11-E J8-E - J11-E J10-E - J11-E</p> <p>Connect meter to;</p> <p><u>high</u> <u>low</u></p> <p>J3-K - J3-E J4-K - J4-E J7-U - J7-E J9-U - J9-E J11-U - J11-E J6-E - J11-E J8-E - J11-E J10-E - J11-E</p>	<p>* * * * * ** ** ** ** **</p> <p>** * * * * ** ** **</p>

+0.04
 Key: *0.40 vrms
 -0.12
 ** = no voltage

Table 3-27. Transmit X-Mode Signal, Performance Standard Tests

Step	Control Settings		Procedure	Performance Standard																																								
	Test Equipment	Equipment Under Test																																										
1	<p>a. Adjust TS-421/U oscillator to deliver 0.6 ± 0.025 vrms at 1000 ± 100 Hz.</p> <p>b. Adjust AN/USM-223 meter to measure 0.5 vrms.</p>	<p>a. Apply +24+, -2.5 vdc from Battery BB-451/U to J1. If BB-451/U is not used, apply 24 ± 1.0 Vdc to J1-B(+) and J1-A(-) from a suitable power supply.</p> <p>b. Set XMT-MODE switch to NORM.</p> <p>c. Set POWER-OFF-ON switch to ON.</p>	<p>a. Apply oscillator output through a 1000:1 resistor pad (figure 3-2) to the HDST/MIC connector J13-D (high) and J13-E (low).</p> <p>b. Connect meter between 1A1A2TB1-E (high) and 1A1A2TB1-F (low).</p>	<p>a. Meter shall indicate $0.40 \pm 0.04, -0.12$ vrms.</p> <p>NOTE</p> <p>If necessary adjust 1A1A2R3 for 0.40 vrms.</p>																																								
2		All XMT-OFF-MON switches to MON.	<p>Connect meter to:</p> <table style="margin-left: 40px;"> <tr> <td style="text-align: center;"><u>high</u></td> <td style="text-align: center;">-</td> <td style="text-align: center;"><u>low</u></td> <td></td> </tr> <tr> <td>J3-K</td> <td>-</td> <td>J3-E</td> <td>0</td> </tr> <tr> <td>J4-K</td> <td>-</td> <td>J4-E</td> <td>0</td> </tr> <tr> <td>J5-K</td> <td>-</td> <td>J5-E</td> <td>0</td> </tr> <tr> <td>J7-U</td> <td>-</td> <td>J7-E</td> <td>X</td> </tr> <tr> <td>J9-U</td> <td>-</td> <td>J9-E</td> <td>X</td> </tr> <tr> <td>J11-U</td> <td>-</td> <td>J11-E</td> <td>X</td> </tr> <tr> <td>J6-E</td> <td>-</td> <td>J6-A</td> <td>0</td> </tr> <tr> <td>J8-E</td> <td>-</td> <td>J8-A</td> <td>0</td> </tr> <tr> <td>J10-E</td> <td>-</td> <td>J10-A</td> <td>0</td> </tr> </table>	<u>high</u>	-	<u>low</u>		J3-K	-	J3-E	0	J4-K	-	J4-E	0	J5-K	-	J5-E	0	J7-U	-	J7-E	X	J9-U	-	J9-E	X	J11-U	-	J11-E	X	J6-E	-	J6-A	0	J8-E	-	J8-A	0	J10-E	-	J10-A	0	
<u>high</u>	-	<u>low</u>																																										
J3-K	-	J3-E	0																																									
J4-K	-	J4-E	0																																									
J5-K	-	J5-E	0																																									
J7-U	-	J7-E	X																																									
J9-U	-	J9-E	X																																									
J11-U	-	J11-E	X																																									
J6-E	-	J6-A	0																																									
J8-E	-	J8-A	0																																									
J10-E	-	J10-A	0																																									

KEY: 0 = no voltage (vrms)
 XA = 1.4 ± 0.5 mvrms
 +0.04
 X = 0.40 vrms
 -0.12

Table 3-27. Transmit X-Mode Signal, Performance Standard Tests (Cont)

Step	Control Settings		Procedure	Performance Standard
	Test Equipment	Equipment Under Test		
3		RADIO 1 XMT-OFF-MON switch to XMT. For RADIO 2 and 3 set to OFF.	Connect meter to: <u>high</u> <u>low</u> J3-K - J3-E J4-K - J4-E J5-K - J5-E J7-U - J7-E J9-U - J9-E J11-U - J11-E J6-E - J6-A J8-E - J8-A J10-E - J10-A	X 0 0 X X X 0 0 0
4		Set XMT-MODE switch to SE-CURE RADIO 1.	Connect meter to: <u>high</u> <u>low</u> J3-K - J3-E J4-K - J4-E J5-K - J5-E J7-U - J7-E J9-U - J9-E J11-U - J11-E J6-E - J6-A J8-E - J8-A J10-E - J10-A	0 0 0 0 X X X 0 0
	Adjust AN/USM-223 meter to measure ohms x 1.		Measure ohms between J3-K and J7-U.	2 ohms max.

KEY: 0 = no voltage (vrms)
 XA = 1.4 ± 0.5 mvrms
 +0.04 vrms
 X = 0.40 vrms
 -0.12

Table 3-27. Transmit X-Mode Signal, Performance Standard Tests (Cont)

Control Settings																																												
Step	Test Equipment	Equipment Under Test	Procedure	Performance Standard																																								
5		a. Jumper J7-M to ground. b. Connect 150 ohm between J6-E and J6-A.	Connect meter to: <table style="margin-left: 40px;"> <tr> <td><u>high</u></td> <td></td> <td><u>low</u></td> </tr> <tr> <td>J3-K</td> <td>-</td> <td>J3-E</td> </tr> <tr> <td>J4-K</td> <td>-</td> <td>J4-E</td> </tr> <tr> <td>JS-K</td> <td>-</td> <td>JS-E</td> </tr> <tr> <td>J7-U</td> <td>-</td> <td>J7-E</td> </tr> <tr> <td>J9-U</td> <td>-</td> <td>J9-E</td> </tr> <tr> <td>J11-U</td> <td>-</td> <td>J11-E</td> </tr> <tr> <td>J6-E</td> <td>-</td> <td>J6-A</td> </tr> <tr> <td>J8-E</td> <td>-</td> <td>J8-A</td> </tr> <tr> <td>J10-E</td> <td>-</td> <td>J10-A</td> </tr> </table>	<u>high</u>		<u>low</u>	J3-K	-	J3-E	J4-K	-	J4-E	JS-K	-	JS-E	J7-U	-	J7-E	J9-U	-	J9-E	J11-U	-	J11-E	J6-E	-	J6-A	J8-E	-	J8-A	J10-E	-	J10-A	<table style="margin-left: 40px;"> <tr><td>0</td></tr> <tr><td>0</td></tr> <tr><td>0</td></tr> <tr><td>0</td></tr> <tr><td>XA</td></tr> <tr><td>XA</td></tr> <tr><td>XA</td></tr> <tr><td>0</td></tr> <tr><td>0</td></tr> <tr><td>0</td></tr> </table>	0	0	0	0	XA	XA	XA	0	0	0
<u>high</u>		<u>low</u>																																										
J3-K	-	J3-E																																										
J4-K	-	J4-E																																										
JS-K	-	JS-E																																										
J7-U	-	J7-E																																										
J9-U	-	J9-E																																										
J11-U	-	J11-E																																										
J6-E	-	J6-A																																										
J8-E	-	J8-A																																										
J10-E	-	J10-A																																										
0																																												
0																																												
0																																												
0																																												
XA																																												
XA																																												
XA																																												
0																																												
0																																												
0																																												
6			Remove Jumper from J7-M.																																									
7		a. XMT MODE to NORM. b. Set RADIO 1 and 3 XMT-OFF-MON switches to OFF. For RADIO 2 set to XMT.	Connect meter to: <table style="margin-left: 40px;"> <tr> <td><u>high</u></td> <td></td> <td><u>low</u></td> </tr> <tr> <td>J3-K</td> <td>-</td> <td>J3-E</td> </tr> <tr> <td>J4-K</td> <td>-</td> <td>J4-E</td> </tr> <tr> <td>J5-K</td> <td>-</td> <td>J5-E</td> </tr> <tr> <td>J7-U</td> <td>-</td> <td>J7-E</td> </tr> <tr> <td>J9-U</td> <td>-</td> <td>J9-E</td> </tr> <tr> <td>J11-U</td> <td>-</td> <td>J11-E</td> </tr> <tr> <td>J6-E</td> <td>-</td> <td>J6-A</td> </tr> <tr> <td>J8-E</td> <td>-</td> <td>J8-A</td> </tr> <tr> <td>J10-E</td> <td>-</td> <td>J10-A</td> </tr> </table>	<u>high</u>		<u>low</u>	J3-K	-	J3-E	J4-K	-	J4-E	J5-K	-	J5-E	J7-U	-	J7-E	J9-U	-	J9-E	J11-U	-	J11-E	J6-E	-	J6-A	J8-E	-	J8-A	J10-E	-	J10-A	<table style="margin-left: 40px;"> <tr><td>0</td></tr> <tr><td>X</td></tr> <tr><td>0</td></tr> <tr><td>X</td></tr> <tr><td>X</td></tr> <tr><td>X</td></tr> <tr><td>X</td></tr> <tr><td>0</td></tr> <tr><td>0</td></tr> <tr><td>0</td></tr> </table>	0	X	0	X	X	X	X	0	0	0
<u>high</u>		<u>low</u>																																										
J3-K	-	J3-E																																										
J4-K	-	J4-E																																										
J5-K	-	J5-E																																										
J7-U	-	J7-E																																										
J9-U	-	J9-E																																										
J11-U	-	J11-E																																										
J6-E	-	J6-A																																										
J8-E	-	J8-A																																										
J10-E	-	J10-A																																										
0																																												
X																																												
0																																												
X																																												
X																																												
X																																												
X																																												
0																																												
0																																												
0																																												
8		Set XM4T-MODE switch to SECURE RADIO 2.	Connect meter to: <table style="margin-left: 40px;"> <tr> <td><u>high</u></td> <td></td> <td><u>low</u></td> </tr> <tr> <td>J3-K</td> <td>-</td> <td>J3-E</td> </tr> <tr> <td>J4-K</td> <td>-</td> <td>J4-E</td> </tr> <tr> <td>J5-K</td> <td>-</td> <td>J5-E</td> </tr> <tr> <td>J7-U</td> <td>-</td> <td>J7-E</td> </tr> </table> KEY: 0 = no voltage (vrms) XA = 1.4 ± 0.5 mvrms +0.04 X = 0.40 vrms -0.12	<u>high</u>		<u>low</u>	J3-K	-	J3-E	J4-K	-	J4-E	J5-K	-	J5-E	J7-U	-	J7-E	<table style="margin-left: 40px;"> <tr><td>0</td></tr> <tr><td>0</td></tr> <tr><td>0</td></tr> <tr><td>X</td></tr> </table>	0	0	0	X																					
<u>high</u>		<u>low</u>																																										
J3-K	-	J3-E																																										
J4-K	-	J4-E																																										
J5-K	-	J5-E																																										
J7-U	-	J7-E																																										
0																																												
0																																												
0																																												
X																																												

Table 3-27. Transmit X-Mode Signal, Performance Standard Tests (Cont)

Step	Control Settings		Procedure	Performance Standard
	Test Equipment	Equipment Under Test		
8 (Cont)	Adjust AN/ USM-223 to measure ohms x 1.		J9-U - J9-E J11-U - J11-E J6-E - J6-A J8-E - J8-A J10-E - J10-A Measure ohms between J4-K, J9-U.	0 X 0 X 0 2.0 ohms max.
9		a. Connect jumper between J9-M and chassis ground. b. Connect 150 ohm resistor be- tween J8-E and J8-A.	Connect meter to: <u>high</u> <u>low</u> J3-K - J3-E J4-K - J4-E J5-K - J5-E J7-U - J7-E J9-U - J9-E J11-U - J11-E J6-E - J6-A J8-E - J8-A J10-E - J10-A	0 0 0 XA 0 XA 0 XA 0
10			Remove jumper from J9-M.	
11		a. Set XMT- MODE switch to NORM. b. RADIO 1 and 2 XMT-OFF-MON switches to OFF. For RADIO 3 set to XMT.	Connect meter to: <u>high</u> <u>low</u> J3-K - J3-E J4-K - J4-E JS-K - J5-E J7-U - J7-E J9-U - J9-E J11-U - J11-E J6-E - J6-A J8-E - J8-A J10-E - J10-A	0 0 X X X X 0 0 0 0

KEY: 0 = no voltage (vrms)
 XA = 1.4 ± 0.5 mvrms
 +0.04vrms
 X = 0.40 vrms
 -0.12

Table 3-27. Transmit X-Mode Signal, Performance Standard Tests (Cont)

Step	Control Settings		Procedure	Performance Standard																																								
	Test Equipment	Equipment Under Test																																										
12	Adjust AN/ USM-223 to x 1.	Set XMT-MODE switch to SE- CURE RADIO 3.	Connect meter to; <table style="margin-left: 20px;"> <tr> <td><u>high</u></td> <td></td> <td><u>low</u></td> </tr> <tr> <td>J3-K</td> <td>-</td> <td>J3-E</td> </tr> <tr> <td>J4-K</td> <td>-</td> <td>J4-E</td> </tr> <tr> <td>J5-K</td> <td>-</td> <td>J5-E</td> </tr> <tr> <td>J7-U</td> <td>-</td> <td>J7-E</td> </tr> <tr> <td>J9-U</td> <td>-</td> <td>J9-E</td> </tr> <tr> <td>J11-U</td> <td>-</td> <td>J11-E</td> </tr> <tr> <td>J6-E</td> <td>-</td> <td>J6-A</td> </tr> <tr> <td>J8-E</td> <td>-</td> <td>J8-A</td> </tr> <tr> <td>J10-E</td> <td>-</td> <td>J10-A</td> </tr> </table>	<u>high</u>		<u>low</u>	J3-K	-	J3-E	J4-K	-	J4-E	J5-K	-	J5-E	J7-U	-	J7-E	J9-U	-	J9-E	J11-U	-	J11-E	J6-E	-	J6-A	J8-E	-	J8-A	J10-E	-	J10-A	<table style="margin-left: 20px;"> <tr><td>0</td></tr> <tr><td>0</td></tr> <tr><td>0</td></tr> <tr><td>X</td></tr> <tr><td>X</td></tr> <tr><td>0</td></tr> <tr><td>0</td></tr> <tr><td>0</td></tr> <tr><td>0</td></tr> <tr><td>X</td></tr> </table> 2.0 ohms max.	0	0	0	X	X	0	0	0	0	X
<u>high</u>			<u>low</u>																																									
J3-K	-	J3-E																																										
J4-K	-	J4-E																																										
J5-K	-	J5-E																																										
J7-U	-	J7-E																																										
J9-U	-	J9-E																																										
J11-U	-	J11-E																																										
J6-E	-	J6-A																																										
J8-E	-	J8-A																																										
J10-E	-	J10-A																																										
0																																												
0																																												
0																																												
X																																												
X																																												
0																																												
0																																												
0																																												
0																																												
X																																												
13		a. Connect jumper between J11-M and chassis ground. b. Connect 150 ohm resistor between J10-E and J10-A.	Connect meter to: <table style="margin-left: 20px;"> <tr> <td><u>high</u></td> <td></td> <td><u>low</u></td> </tr> <tr> <td>J3-K</td> <td>-</td> <td>J3-E</td> </tr> <tr> <td>J4-K</td> <td>-</td> <td>J4-E</td> </tr> <tr> <td>J5-K</td> <td>-</td> <td>J5-E</td> </tr> <tr> <td>J7-U</td> <td>-</td> <td>J7-E</td> </tr> <tr> <td>J9-U</td> <td>-</td> <td>J9-E</td> </tr> <tr> <td>J11-U</td> <td>-</td> <td>J11-E</td> </tr> <tr> <td>J6-E</td> <td>-</td> <td>J6-A</td> </tr> <tr> <td>J8-E</td> <td>-</td> <td>J8-A</td> </tr> <tr> <td>J10-E</td> <td>-</td> <td>J10-A</td> </tr> </table>	<u>high</u>		<u>low</u>	J3-K	-	J3-E	J4-K	-	J4-E	J5-K	-	J5-E	J7-U	-	J7-E	J9-U	-	J9-E	J11-U	-	J11-E	J6-E	-	J6-A	J8-E	-	J8-A	J10-E	-	J10-A	<table style="margin-left: 20px;"> <tr><td>0</td></tr> <tr><td>0</td></tr> <tr><td>0</td></tr> <tr><td>XA</td></tr> <tr><td>XA</td></tr> <tr><td>0</td></tr> <tr><td>0</td></tr> <tr><td>0</td></tr> <tr><td>XA</td></tr> </table>	0	0	0	XA	XA	0	0	0	XA	
<u>high</u>		<u>low</u>																																										
J3-K	-	J3-E																																										
J4-K	-	J4-E																																										
J5-K	-	J5-E																																										
J7-U	-	J7-E																																										
J9-U	-	J9-E																																										
J11-U	-	J11-E																																										
J6-E	-	J6-A																																										
J8-E	-	J8-A																																										
J10-E	-	J10-A																																										
0																																												
0																																												
0																																												
XA																																												
XA																																												
0																																												
0																																												
0																																												
XA																																												
14			Remove jumper from J11-M.																																									
15	Adjust AN/ USM-223 to X1.	a. Apply 9 vdc to J7-L (+) and J7-N (-). b. Remove the 9 vdc.	Measure ohms between: J3-L, J7-F J7-H, Ground J7-G, Ground J7-J, Ground Repeat measurements in a.	20.0 ohms max. No change																																								

KEY: 0 - no voltage (vrms)
 XA = 1.4 ± 0.5 mvrms
 +0.04
 X = 0.40 vrms
 -0.12

Table 3-27. Transmit X-Mode Signal, Performance Standard Tests (Cont)

Step	Control Settings		Procedure	Performance Standard
	Test Equipment	Equipment Under Test		
15 (Cont)		c. Set POWER-OFF-ON switch to OFF.	Repeat measurements in a.	1 meg ohm.
16	Adjust AN/USM-223 to X1.	a. Apply 9 vdc to J9-L(+) and J9-N(-).	Measure ohms between: J4-L, J9-F	20.0 ohms max.
		b. Set POWER OFF-ON switch to ON.	J9-H, Ground J9-G, Ground J9-J, Ground	
		c. Remove the 9 vdc.	Repeat measurements in a.	No change
		d. Set POWER OFF-ON switch to OFF.	Repeat measurements in a.	1 meg ohm
17	Adjust AN/USM-223 to X1.	a. Apply 9 vdc to J11-L(+) and J9-N(-).	Measure ohms between: J5-L, J11-F	20.0 ohms max.
		b. Set POWER OFF-ON switch to ON.	J11-H, Ground J11-G, Ground J11-J, Ground	
		c. Remove the 9 vdc.	Repeat measurement in a.	No change
		d. Set POWER OFF-ON switch to OFF.	Repeat measurements in a.	1 meg ohm.

CHAPTER 4

GENERAL SUPPORT MAINTENANCE

4-1. Scope. General support maintenance includes instructions for disassembly, repair and reassembly of the ML-653/TSQ-97 Wind Direction and Speed Detector.

4-2. Tools, Materials and Test Equipment Required.

(1) Audio Oscillator TS-421/U

(2) Multimeter AN/USM-223

(3) Tool Kit Electronic Equipment TK-105/G

(4) Tool Kit Electronic Equipment TK-105/G

4-3. Disassembly and Reassembly of Wind Direction and Speed Detector ML-653/TSQ-97 (Fig. 4-1).

a. To replace Impeller: Unscrew and remove hub (2), replace impeller (3) and reinstall hub, the protruding keys of the generator shaft (4) fit to the larger holes in the impeller.

b. To replace Generator (9):

(1) Remove hub (2) and impeller (3) as noted above.

(2) Pull vane assembly (29) from cap (24).

(3) Remove screws (11) from generator housing (10) and separate cap (24).

(4) Remove screws (27) from terminal board (25) holding wires from generator (9) and shaft (36), note color coding (see FO-3).

(5) Remove screws from front of housing (10) and separate cap assy (7), shaft (4) and generator (9).

(6) Loosen set screws (5) via access hole in item (7), remove screws (12) and separate generator (10).

(7) Replace generator, with new lugs, install all wiring to terminal strip and reinstall all parts except cap (24).

(8) Align generator output by adjusting variable resistor (20). See paragraph 4-4.

(9) Reinstall cap (24), impeller (3), hub (2) and vane (29).

c. To replace Synchro (43):

(1) Remove hub (2), impeller (3) and vane (29).

(2) Remove screws (11) from generator housing (10) and separate cap (24), remove screws (27) from terminal board (25) securing wiring from shaft (36) and generator (9), note color coding (fig. FO-3).

(3) Remove screws (11) from housing front end (10) and separate generator (9) and cap assy (4 & 7) from the housing.

(4) Loosen set screws (15) and disengage housing (10) and indicator (16) from shaft (36) allowing wiring to pull through access hole.

(5) Remove screws from top of (57). Separate housing (57) from synchro assembly (31A).

(6) Remove connector (46) from base (48) and note color coding of synchro (43) wires to connector (see FO-3). Unsolder wires.

(7) Disassemble synchro (43) from assembly (31A), replace synchro, solder wires to connector (46) and reassemble. The circuit board of shaft (36) shall be spaced above plate (39) .250 ± .005 set-screws only amount necessary to inches by coupling setscrew (56), bottom of shaft (36).

(8) The synchro output shall be aligned, in accordance with 4-17, with the detector reassembled, except the hub, impeller and vane.

(9) Replace hub, impeller and vane.

d. To replace Variable Resistor (20):

(1) Disassemble as needed (b above).

(2) Adjust resistor by same procedure as noted in generator replacement paragraph.

(3) Reassemble.

4-4. Wind Speed Adjustment Procedure.

a. Connect detector as shown in figure 4-2, wind speed output portion.

b. Couple the generator shaft (impeller removed) to synchronous motor, Bodine part number 702 (3600 RPM) or any stable source equivalent to 13-20 knots at 212.23 RPM per Kt.

$$\text{Speed (Kts)} = \frac{\text{Actual RPM}}{212.23 \text{ RPM per Kt}}$$

c. Apply input power to synchronous motor.

d. The output of the Wind Detector (generator) TP1(+) and TP2(-), see figure 4-2, should be adjusted to 0.1304 volts per knot with R1, behind the end cap of the generator assembly. The output shall be adjusted to 2.212 ± 0.010 vdc (16.963 knots) for the 3600 rpm Bodine #702 motor above. Output voltage = Speed (Kts) x 0.1304 VDC/ Knots.

4-5. Wind Direction Alignment Procedures:

a. Following assembly/disassembly instructions, of 4-3 , remove generator assembly and the upper synchro assembly set-screws only amount necessary to

b. Install a Wind Direction Alignment fixture see figure 4- Align the reference mark with the Reference line above the connector This test assembly simulates an upper synchro assembly housing containing the direction reading (reference) mark with the cutouts to allow access to the synchro and the synchro retaining clamps.

c. Install the generator assembly, generator hook-up to detector TB1 not required

d. Connect detector, synchro "cx" portion, as shown in figure 4-2. Align the Azimuth Indicator outer numbers (card), zero degrees to top pointer.

e. Loosen synchro retaining clamps, align and hold detector zero degrees to the reference mark and rotate the synchro to electrical zero by pointer of the Azimuth Indicator.

f. Tighten synchro clamps, remove generator assembly and the "test upper synchro assembly housing".

g. Install the upper synchro assembly housing and the generator assembly.

h. Confirm detector to Azimuth Indicator zero alignment.

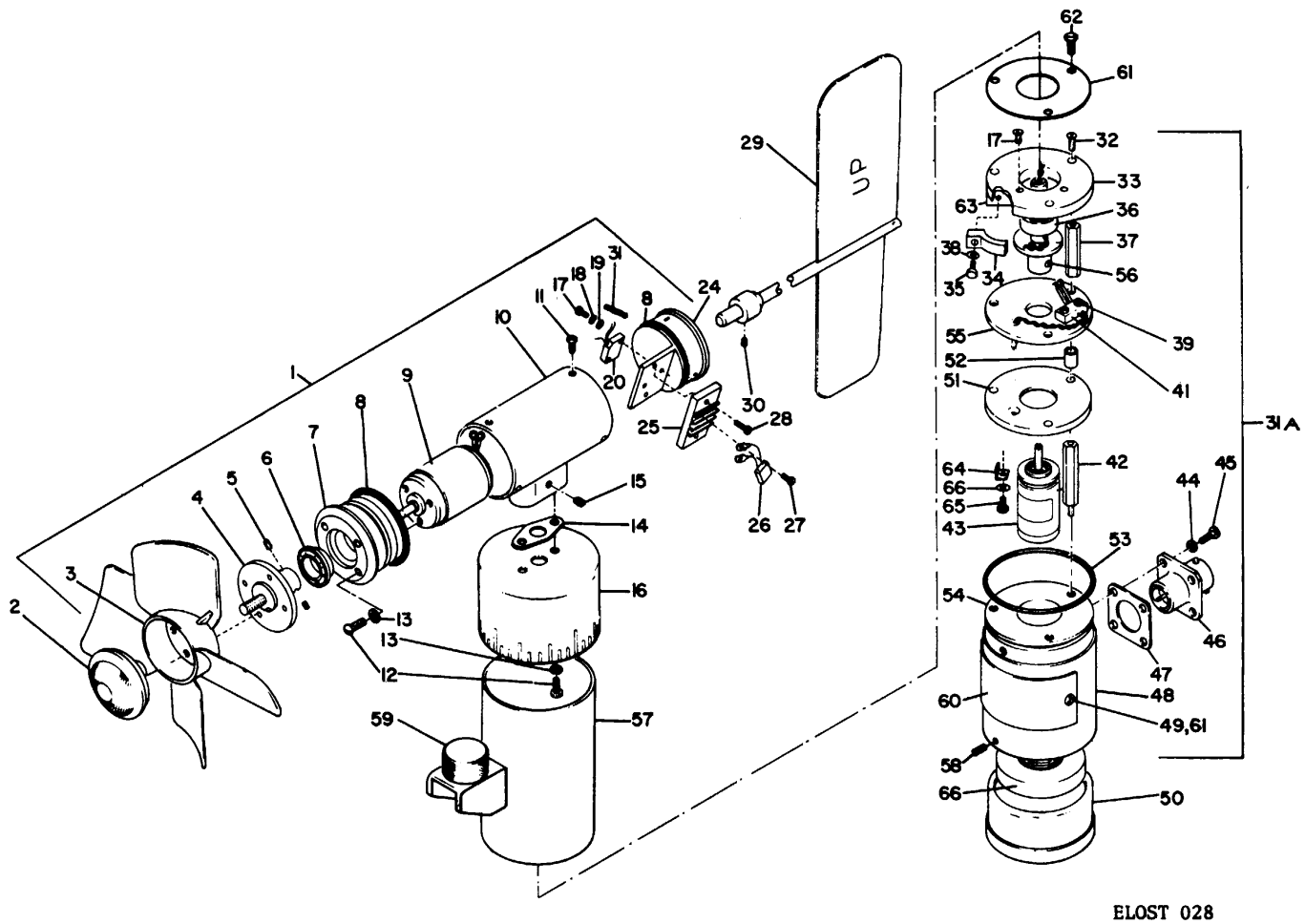

ELOST 028

Figure 4-1. Wind Direction and Speed Detector, ML-6S3/TSQ-97, Exploded View

Legend for Figure 4-1.

- | | |
|----------------------|------------------------|
| 1 Generator assembly | 32 Screw |
| 2 Hub | 33 Plate |
| 3 Impeller | 34 Bearing clamp |
| 4 Shaft | 35 Screw |
| 5 Set screw | 36 Shaft |
| 6 Bearing | 37 Standoff, hex |
| 7 Cap | 38 Washer |
| 8 Gasket ("O" Ring) | 39 Plate |
| 9 Generator | 40 _____ |
| 10 Housing | 41 Brush assembly |
| 11 Screw | 42 Standoff, hex |
| 12 Screw | 43 Synchro-transmitter |
| 13 Lockwasher | 44 Washer |
| 14 Gasket | 45 Screw |
| 15 Set screw | 46 Connector |
| 16 Indicator | 47 Gasket |
| 17 Screw | 48 Base |
| 18 Lockwasher | 49 Screw |
| 19 Flatwasher | 50 Compass assembly |
| 20 Variable resistor | 51 Plate |
| 21 _____ | 52 Spacer |
| 22 _____ | 53 "O" ring |
| 23 _____ | 54 _____ |
| 24 Cap | 55 _____ |
| 25 Terminal board | 56 _____ |
| 26 Capacitor | 57 Housing |
| 27 Screw | 58 Set screw |
| 28 Screw | 59 Knurled thumbscrew |
| 29 Vane assembly | 60 _____ |
| 30 Set screw | 61 _____ |
| 31 Plunger | 62 _____ |
| 31A Synchro assembly | 63 _____ |

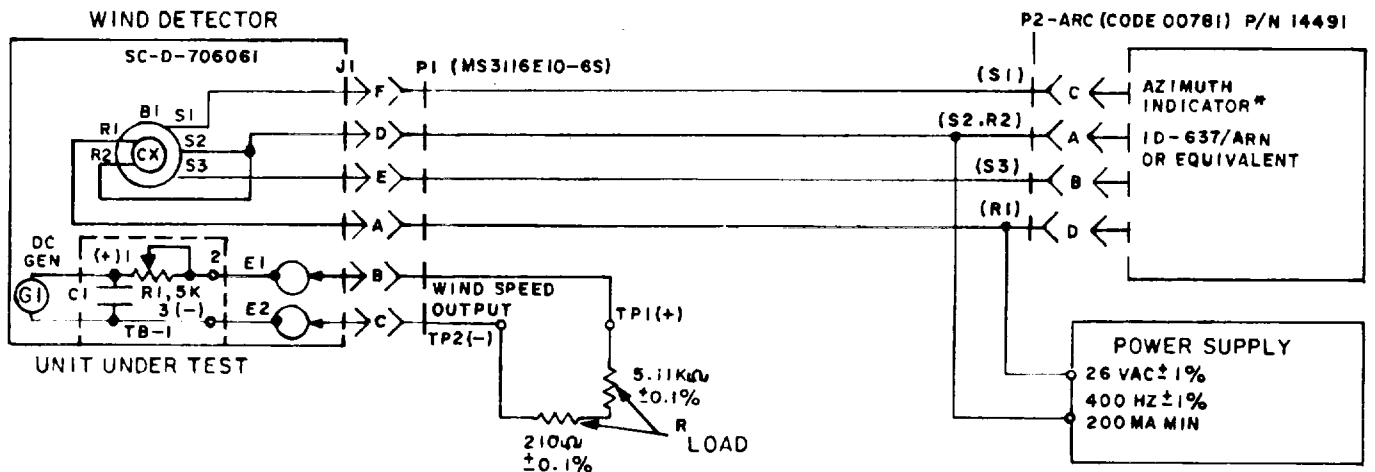

NOTE:
 INDICATOR SUBSTITUTE: SYNCHRO RECEIVER WITH CALIBRATED DIAL-POINTER
 PER MIL-S-20708C/5 (26V-(1TR4C).

Figure 4-2. Wind Speed Adjustment Connections

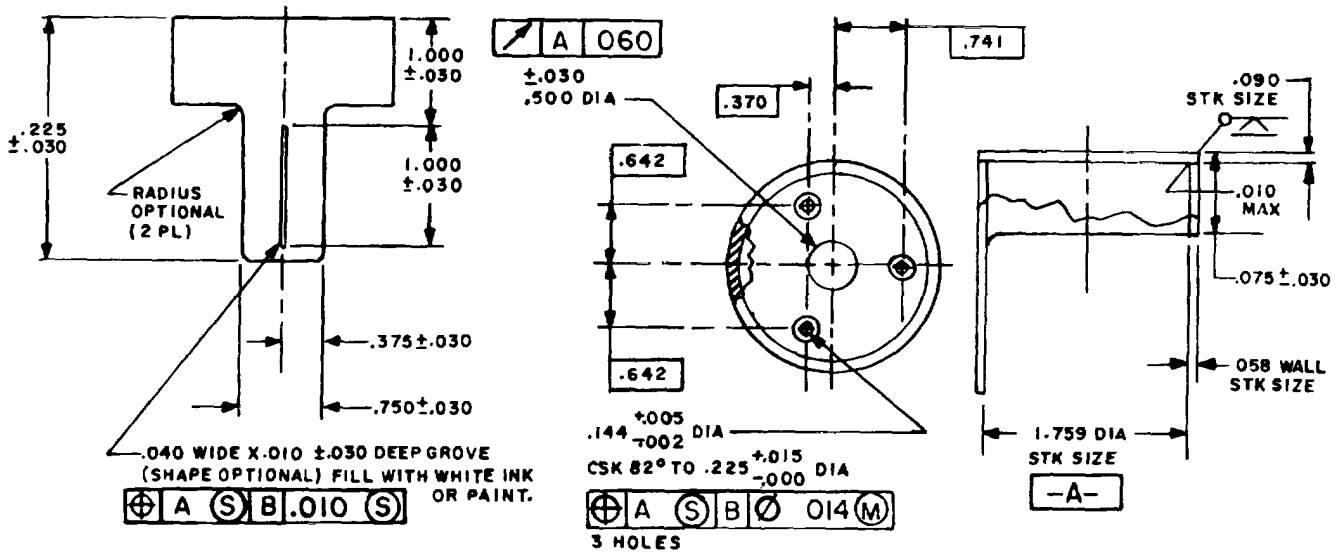

Figure 4-3. Wind Direction Alignment Fixture

4-5/(4-6 blank)

APPENDIX A REFERENCES

- Following is a list of references available to the maintenance technician of the Air Traffic Control Facility AN/TSQ-97.
DA Pam 310-4 Index of Technical Publications.
- | | |
|--|--|
| KAO-153/TSEC (RP-2)
Confidential Publication) | Operating Instructions for the TSEC/KY-8/28/38. (U) |
| SB 11-573 | Painting and Preservation of Supplies Available for Field Use for Electronics Command Equipment. |
| SB 38-100 | Preservation, Packaging, Packing and Marking Materials, Supplies and Equipment Used by the Army. |
| SB 700-20 | Army Adopted/Other Items Selected for Authorization/List of Reportable Items. |
| TB SIG 291 | Safety Measures to be Observed When Installing and Using Whip Antennas, Field-Type Masts, Towers and Antennas and Metal Poles That Are Used With Communications, Radar and Direction Finder Equipment. |
| TB 43-0118 | Field Instructions for Painting and Preserving Electronics Command Equipment Including Camouflage Pattern Painting of Electrical Equipment Shelters. |
| TM 11-5821-259-20 | Organizational Maintenance Manual: Radio Sets, AN/ARC-114 and AN/ARC-114A; Network, Impedance Matching, CU-1794/ARC-114; Network, Impedance Matching-Quadrature Hybrid, CU-1796/ARC-114. |
| TM 11-5821-260-12-1 | Operator's and Organizational Maintenance Manual: Radio Set, AN/ARC-115A(%)I (NSN 5821-01-057-4037). |
| TM 11-5895-800-12 | Operator's and Organizational Maintenance Manual: Air Traffic Control Facility AN/TSQ-97 (NSN 5895-00-137-8548). |
| TM 11-6140-208-15 | Organizational, Direct Support, General Support, and Depot Maintenance Manual: Battery, Storage, BB-451/U (NSN 6140-00-889-1027). |
| TM 38-750 | The Army Maintenance Management System (TAMMS). |
| TM 750-244-2 | Procedures for Destruction of Electronics Materiel to Prevent Enemy Use (Electronics Command). |

Change 1 A-1/ A-2 Blank)

APPENDIX B

EXPENDABLE SUPPLIES AND MATERIALS LIST

Section I. INTRODUCTION

B-1. Scope. This appendix lists expendable supplies and materials you will need to operate and maintain the Air Traffic Control Facility. These items are authorized to you by CTAS0-970, Expendable Items (except Medical, Class V, Repair Parts, and Heraldic Items).

F -Direct Support Maintenance
H - General Support Maintenance

B-2. Explanation of Columns

a. Column 1 - Item Number. This number is assigned to the entry in the listing and is referenced in the narrative instructions to identify the material (e.g., "Use cleaning compound, item S, App. B").

c. Column 3 - National Stock Number. This is the National stock number assigned to the item; use it to request or requisition the item.

d. Column 4 - Description. Indicates the Federal item name and if required, a description to identify the item. The last line for each item indicates the part number followed by the Federal Supply Code for Manufacturer (FSCM) in parentheses, if applicable.

b. Column 2 - Level. This column identifies the lowest level of maintenance that requires the listed item.

e. Column 5 - Unit of Measure (U/M). Indicates the measure used in performing the actual maintenance function. This measure is expressed by a two-character alphabetical abbreviation (e.g., ea. in. pr). If the unit of measure differs from the unit of issue, requisition the lowest unit of issue that will satisfy your requirements.

(enter as applicable)

C - Operator/Crew
O - Organizational Maintenance

Section II. TABULAR LISTING

(1) ITEM NO.	(2) <u>LEVEL</u>	(3) <u>NSN</u>	(4) <u>DESCRIPTION</u>	(5) <u>U/M</u>
1	F		Adhesive, MIL-A-46146, Type I, Gray	AR

U.S. GOVERNMENT PRINTING OFFICE : 1992 0 - 311-831 (60705)

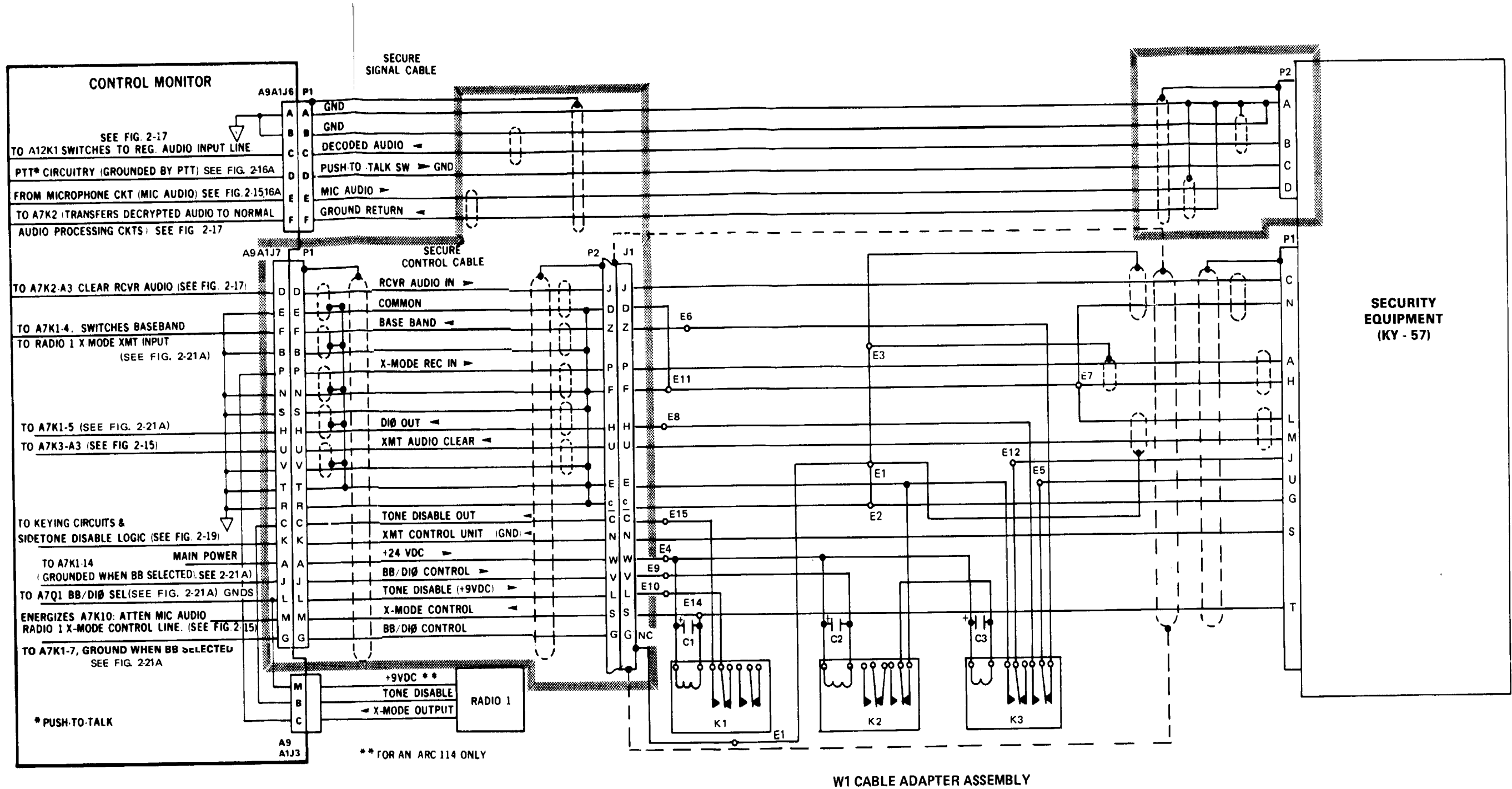
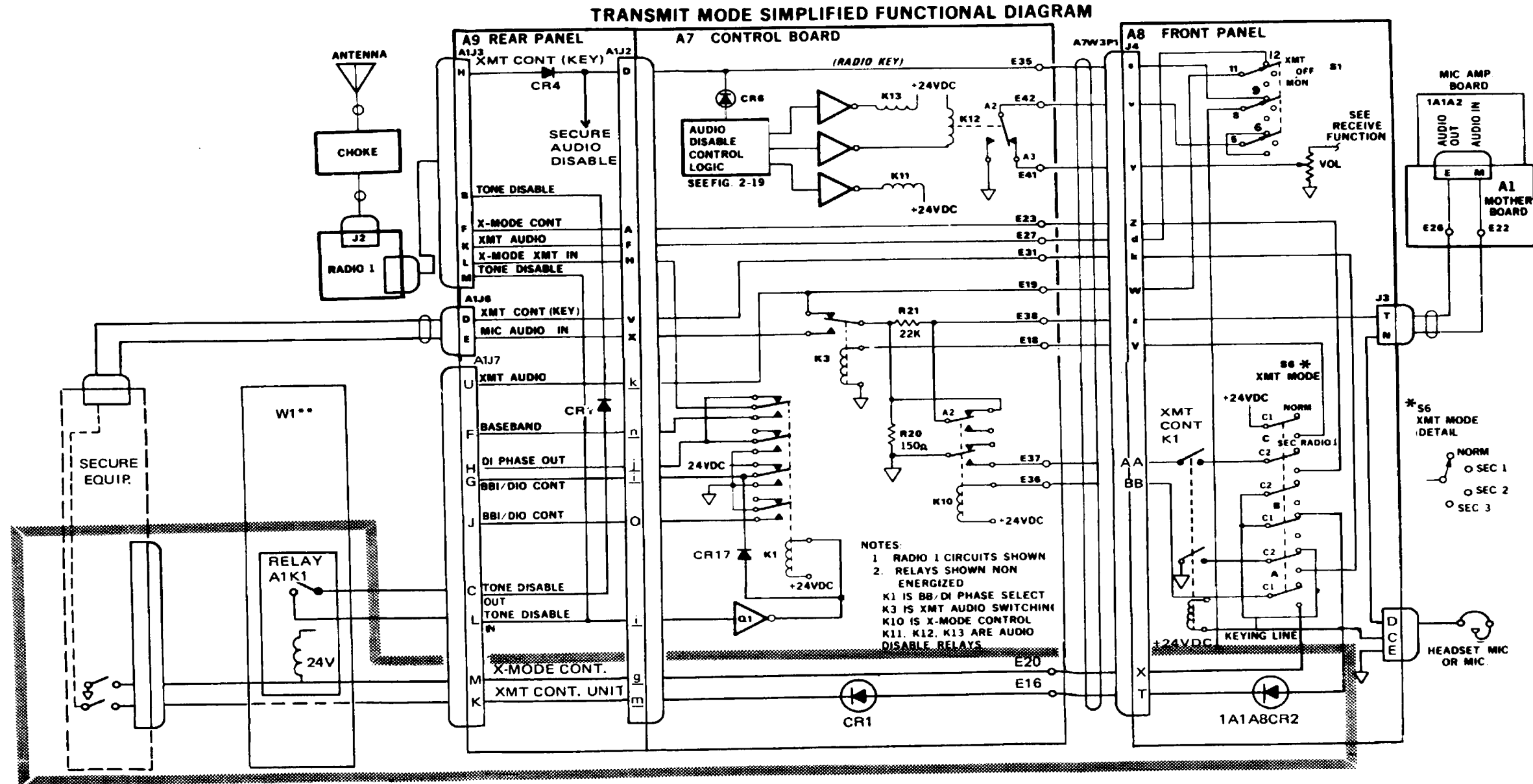

Figure 2-11A. Control Monitor/
TSEC/KY-57 Interface

Change 2 2-17/(2-18 blank)



**ADAPTER CABLE ASSEMBLY W1 USED WITH TSEC/KY-57 ONLY

ELOST 017

Figure 2-16A. Transmit Audio (X-Mode) Using TSEC/KY-57 Security Equipment, Simplified Functional Diagram

Change 2 2-23/ (2-24 blank)

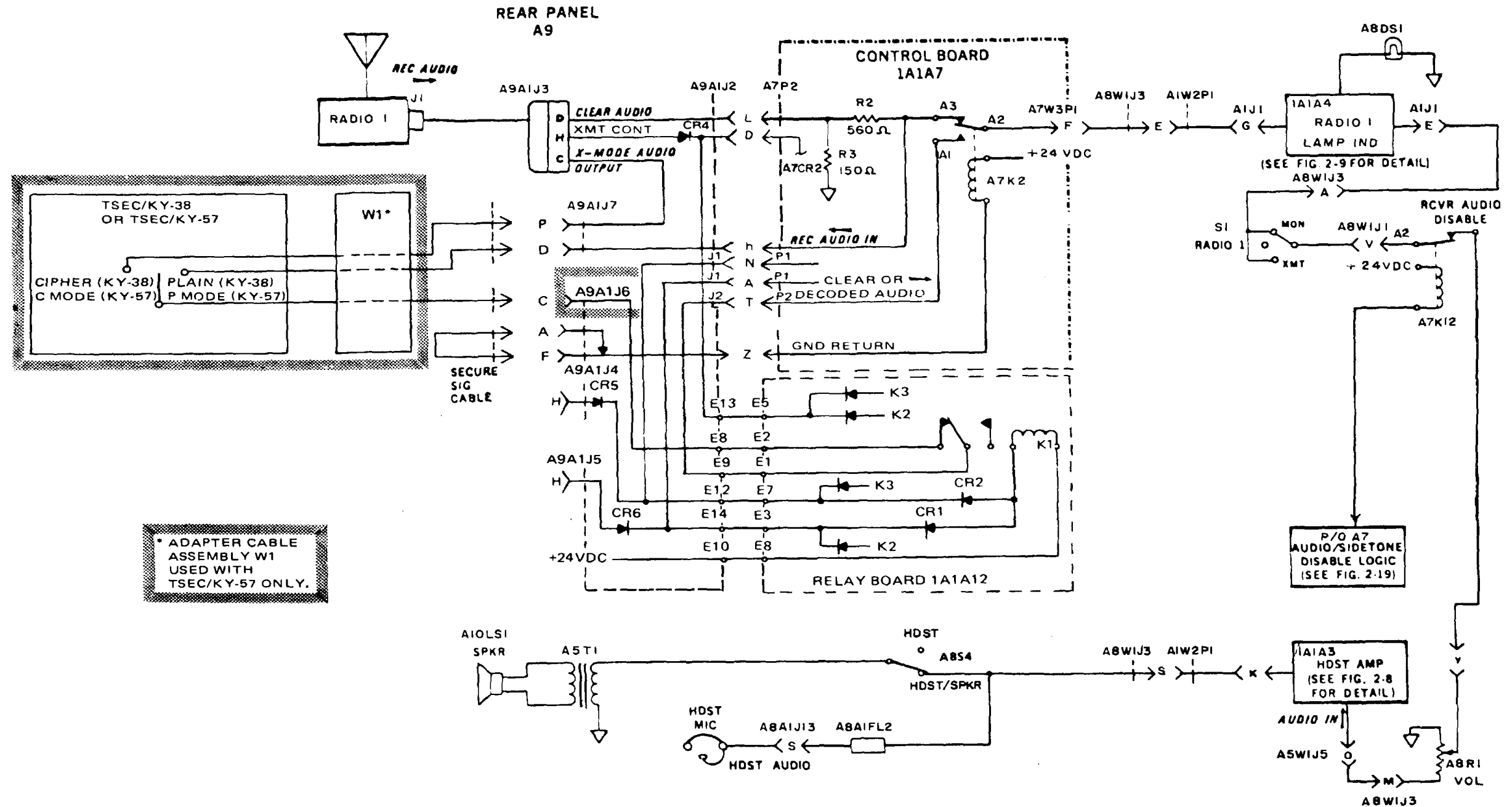

RECEIVE AUDIO (CLEAR & X-MODE), SIMPLIFIED SIGNAL FLOW DIAGRAM

Figure 2-17. Receive Audio, Simplified Signal Flow Diagram

Change 2 2-27/(2-28 blank)

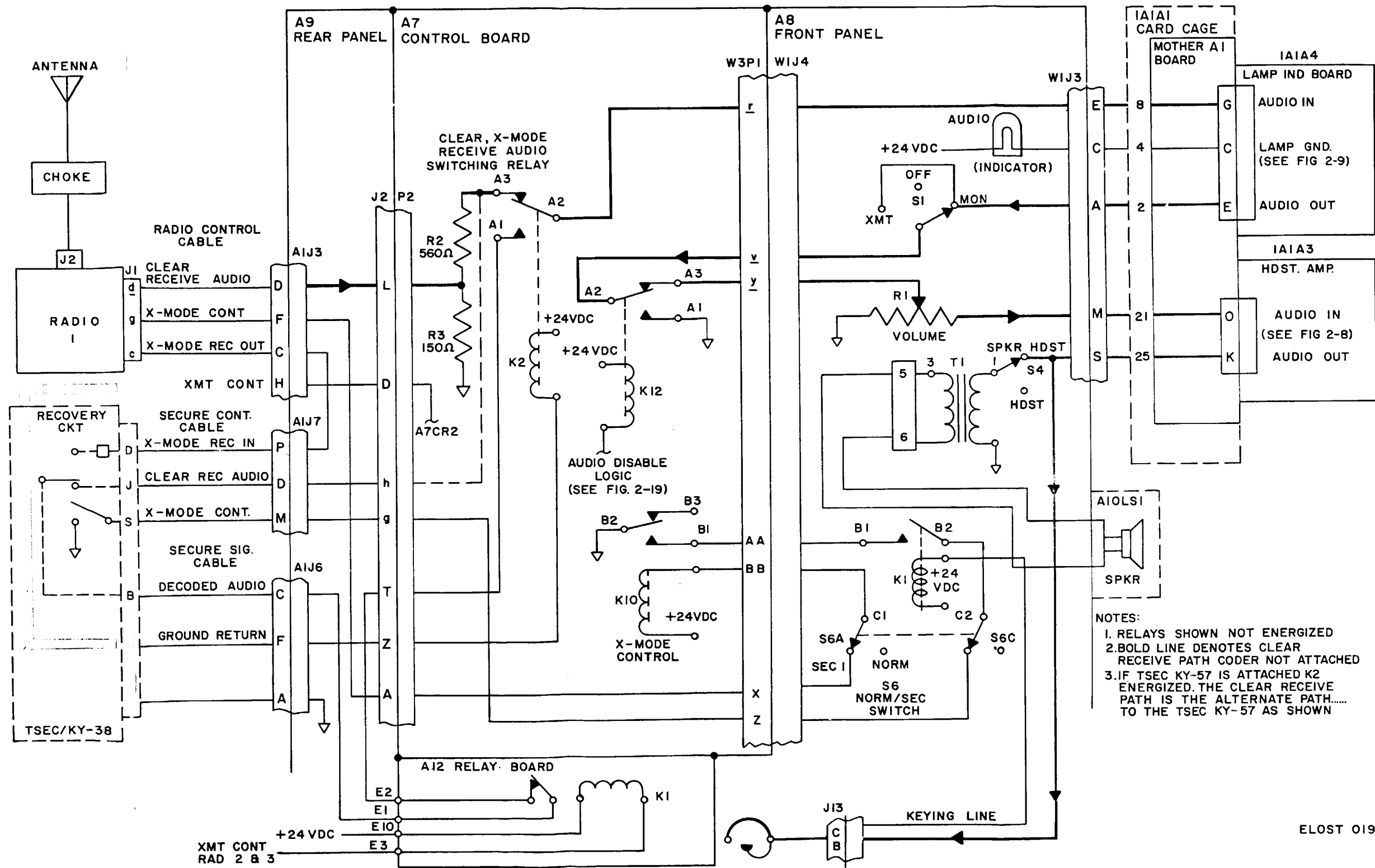
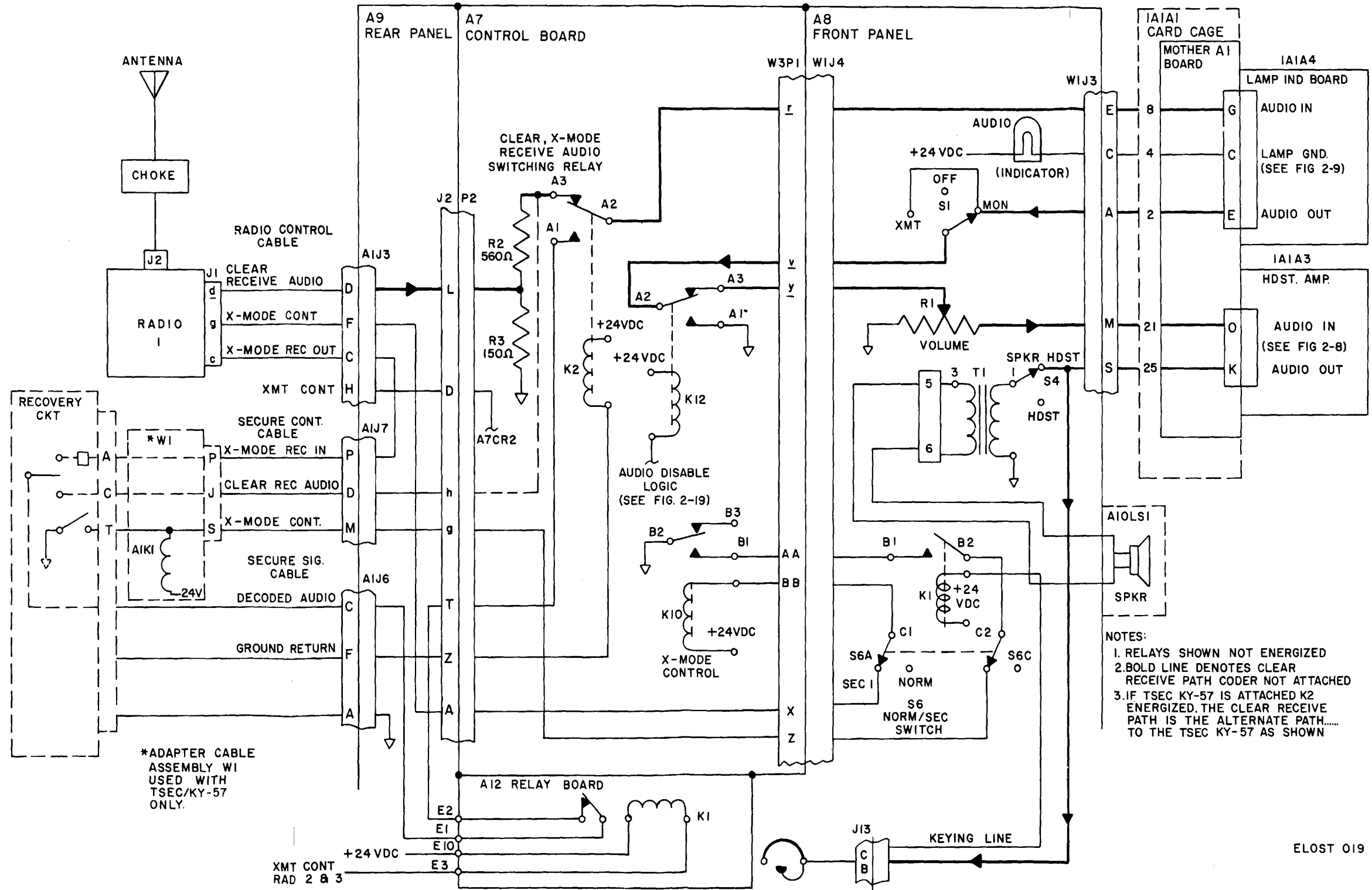

Figure 2-18. Receive Mode, with TSEC/KY-38 Security Equipment, Simplified Functional Diagram

Change 2 2-29/(2-30 blank)



ELOST 019

Figure 2-18A. Receive Mode, With TSEC/KY-57 Security Equipment, Simplified Functional Diagram

KEYING CIRCUITS

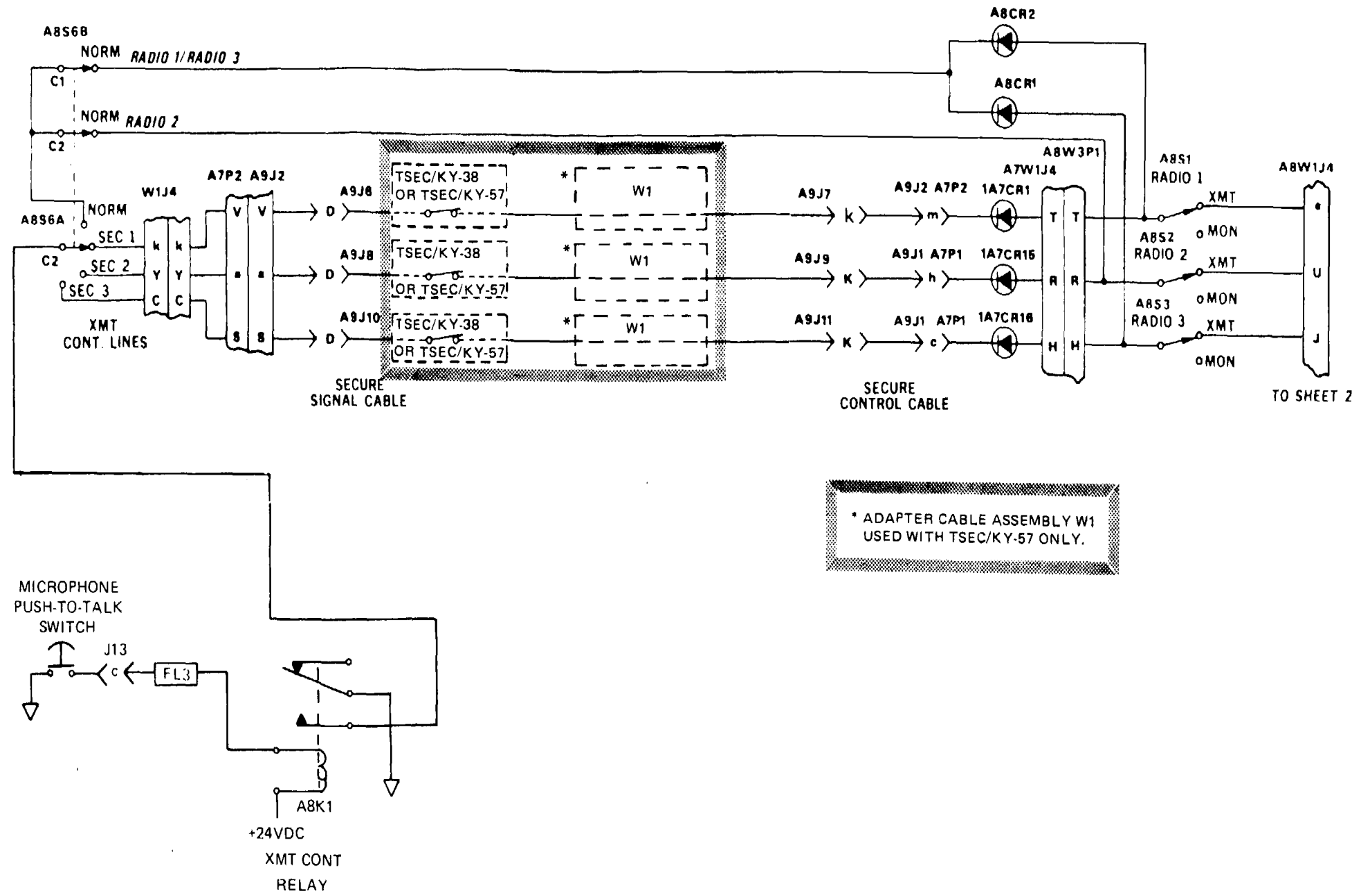

ELOST 020

Figure 2-19. Keying Circuits and Audio Disable (Sheet 1 of 2)

Change 2 2-33/(2-34 blank)

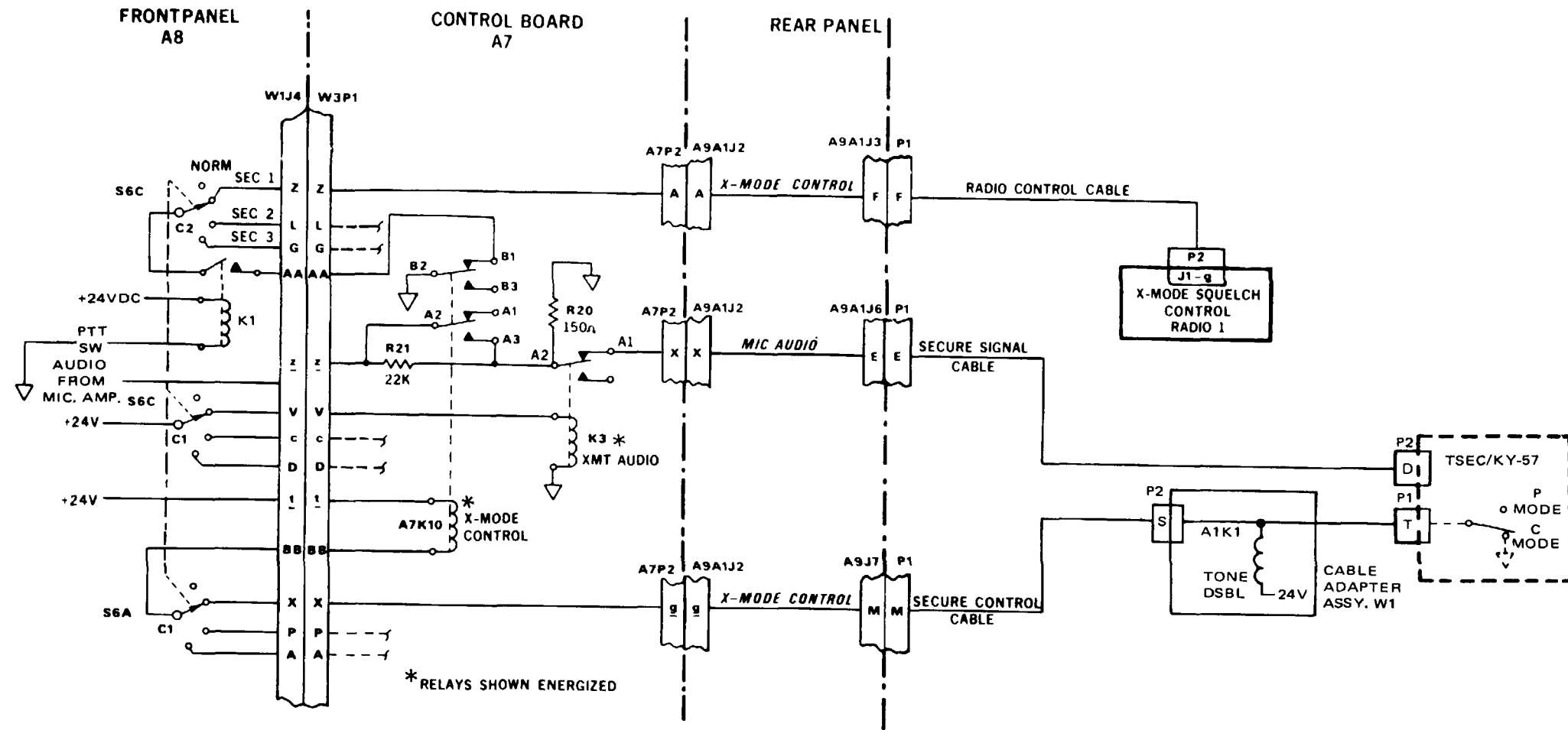

X-MODE CONTROL CIRCUITS SIMPLIFIED SIGNAL FLOW DIAGRAM

ELOST 022

Figure 2-20A. X Mode Control Circuits With TSEC/ KY-57 Security Equipment, Simplified Signal Flow Diagram

Change 2

2-37/(2-38 blank)

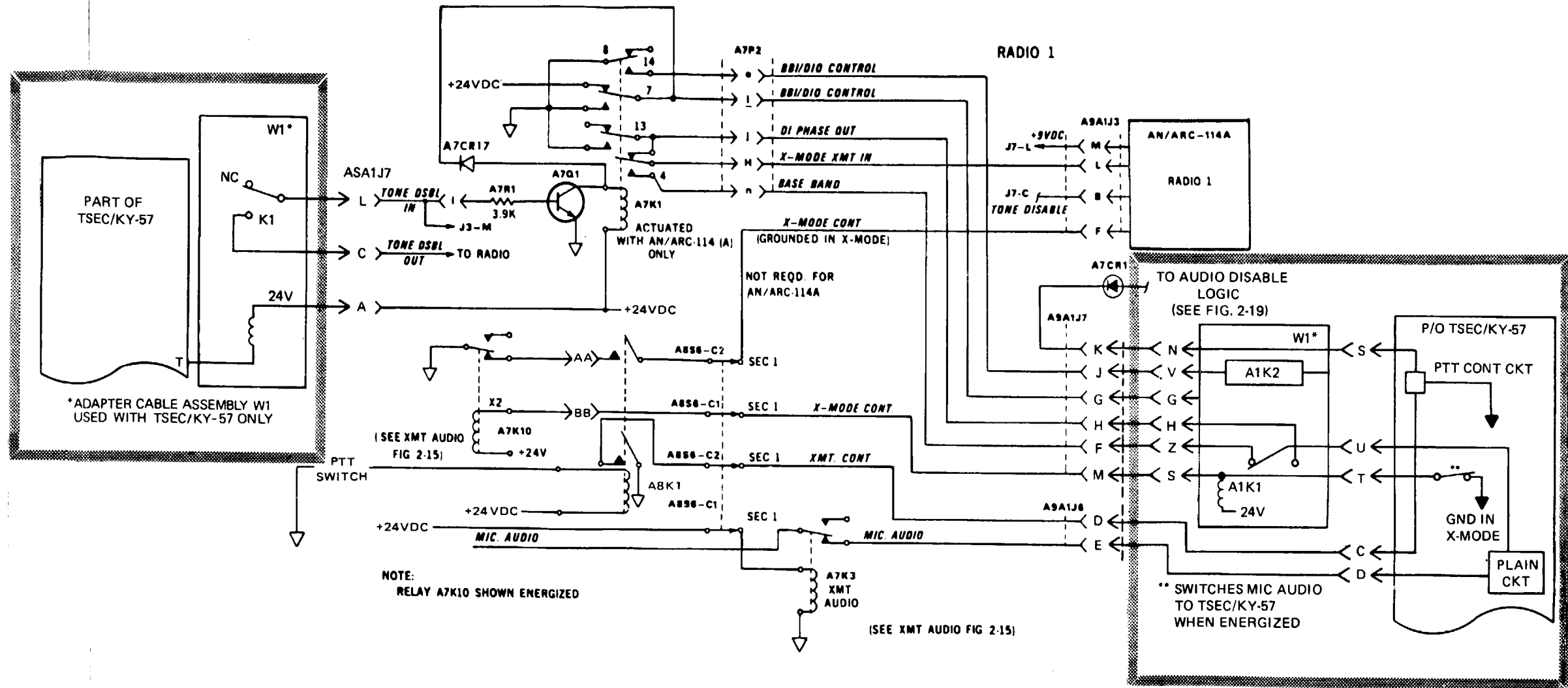

BASE-BAND/DI-PHASE SELECT SIMPLIFIED SIGNAL FLOW DIAGRAM

ELOST 023

Figure 2-21A.. Base Band/DI Phase Select, Using TSEC/KY-57 Security Equipment, Simplified Signal Flow Diagram

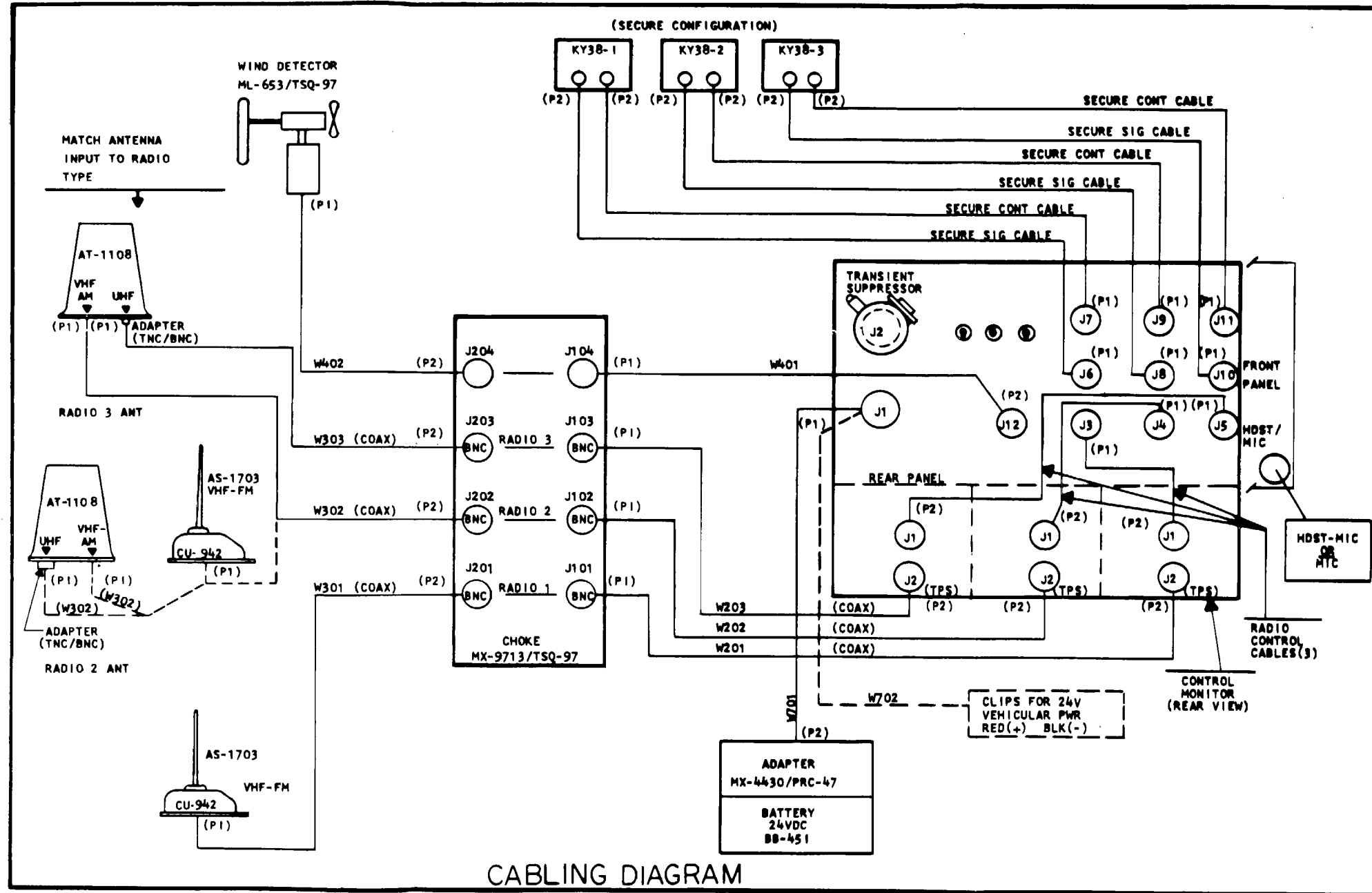

FO-1. Cabling Diagram
AN/TSQ-97 System

FO-1/FO-2 Blank

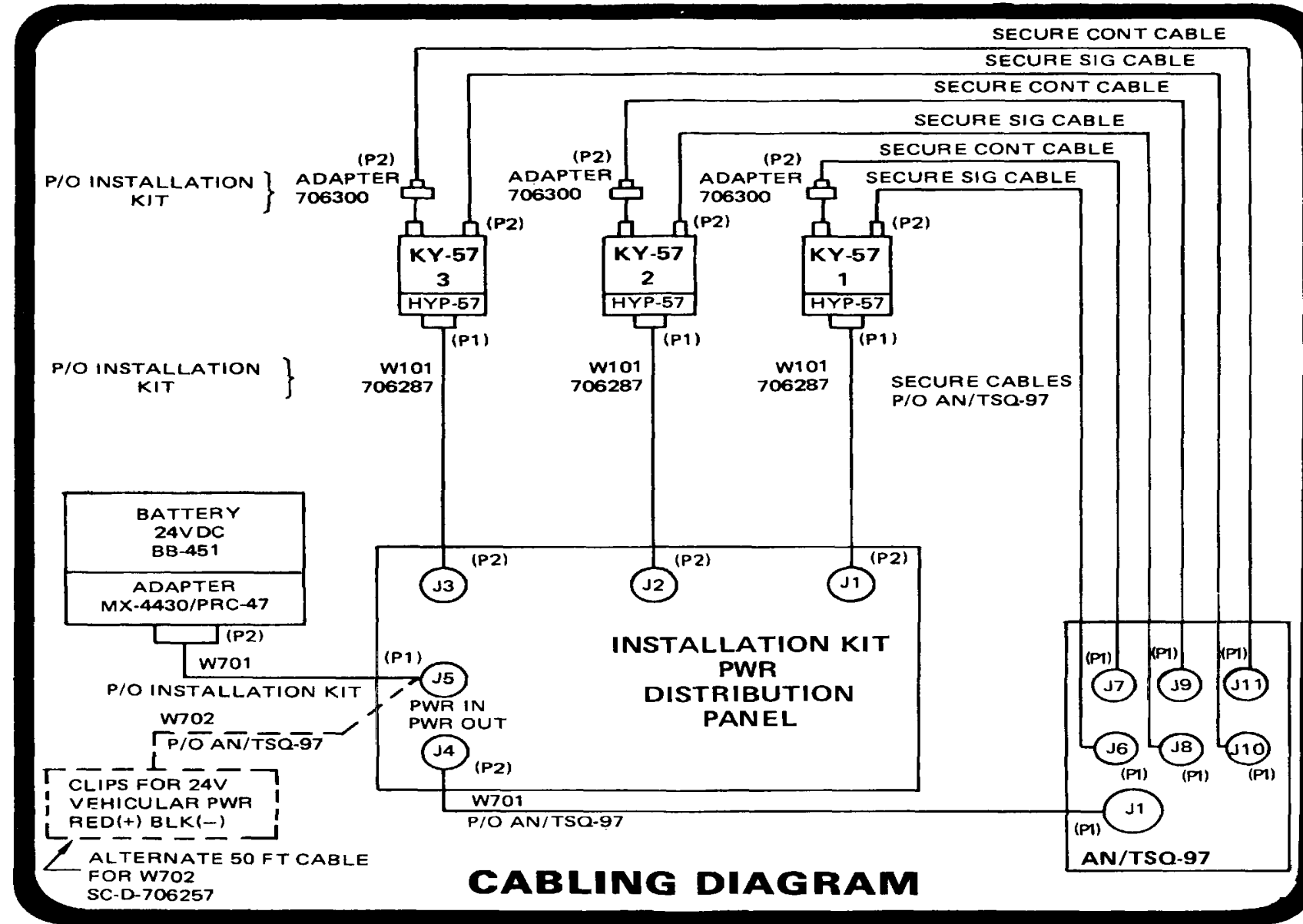

FO-1A. Cable Diagram MK-2225/TSQ-97
Installation Kit

Change 2 FO-1A/(FO-1B blank)

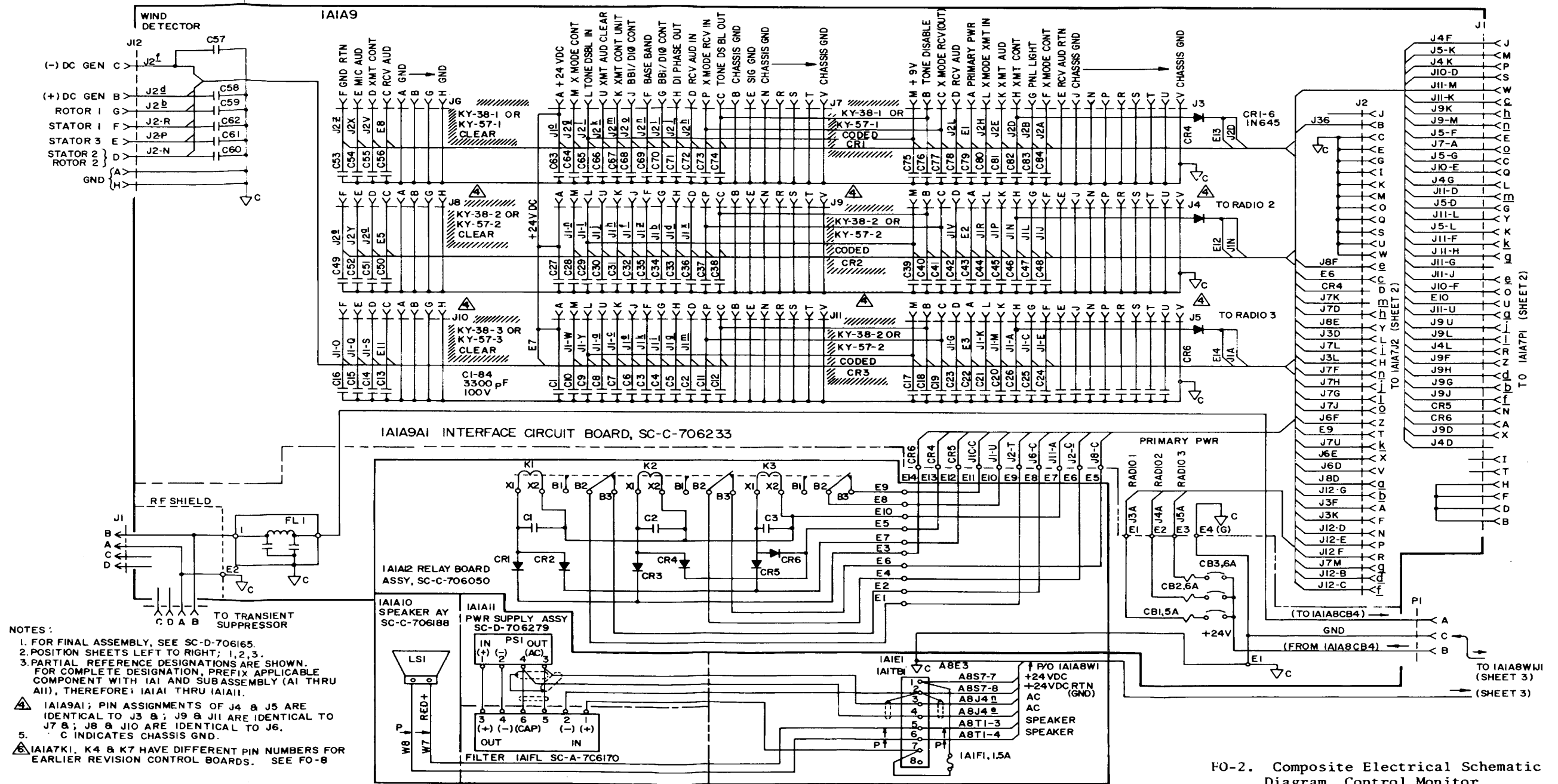

FO-2. Composite Electrical Schematic Diagram, Control Monitor C-9921/TSQ-97 (Sheet 1 of 3)

FO-2. Composite Electrical Schematic Diagram, Control Monitor C-9921/TSQ-97 (Sheet 1 of 3)

Change 2

FO-3/(FO-4 blank)

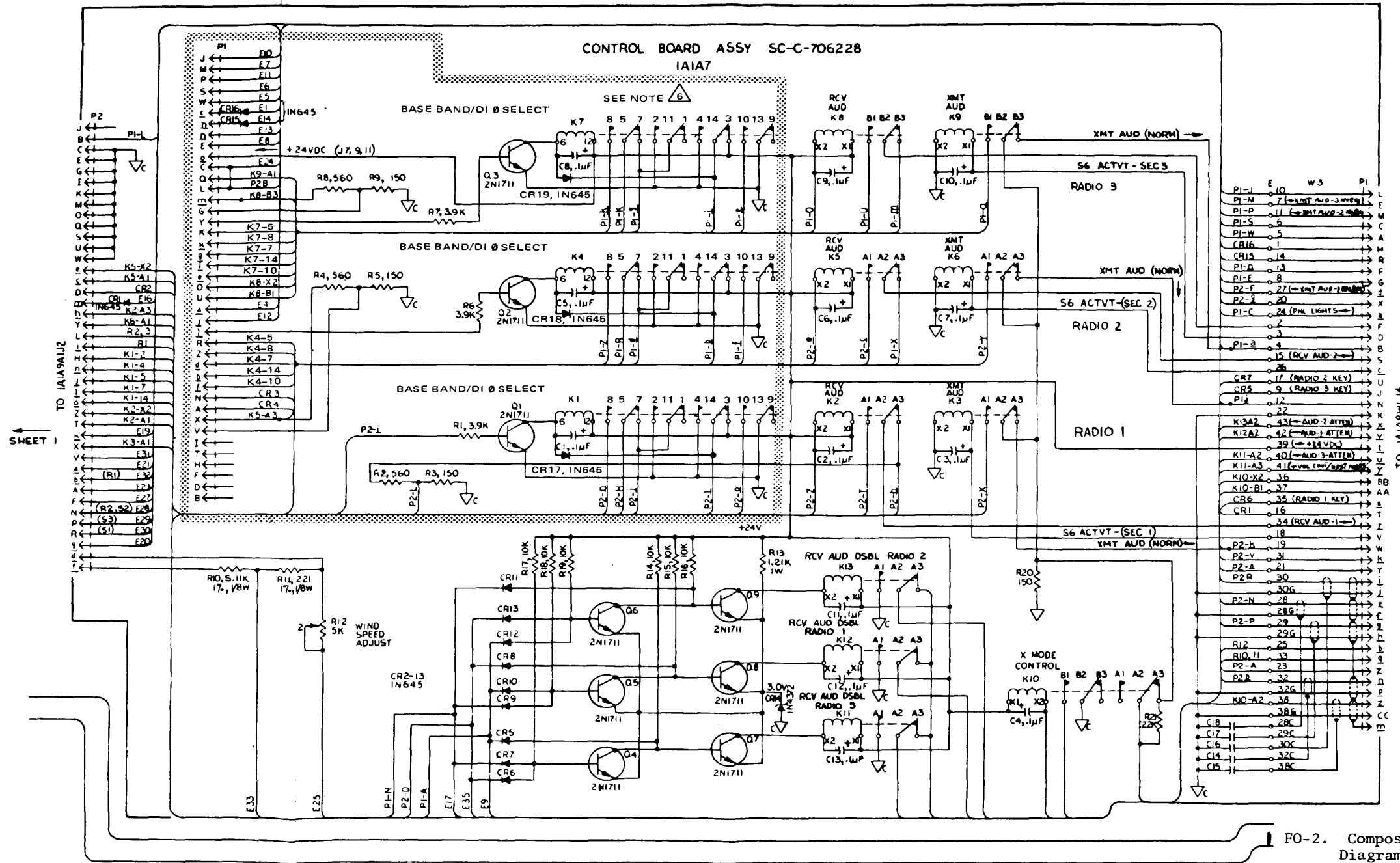

FO-2. Composite Electrical Schematic Diagram, Control Monitor C-9921/TSQ-97 (Sheet 2 of 3)

FO-2 Composite Electrical Schematic Diagram Control Monitor C-9921/TSQ-97 (Sheet 2 of 3)

Change 1 FO-5/(FO-6 Blank)

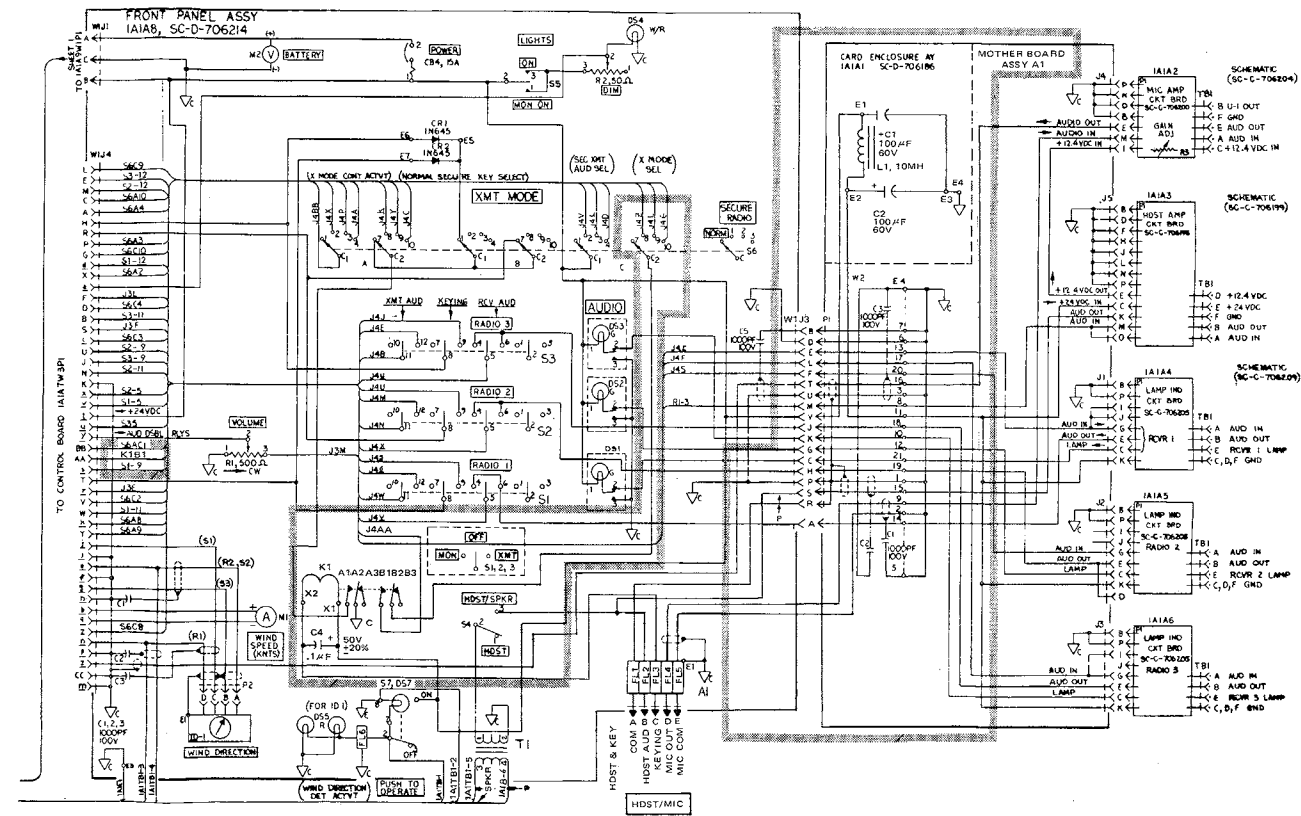

FO-2. Composite Electrical Schematic Diagram, Control Monitor C-9921/TSQ-97 (Sheet 3 of 3)

Change 1 FO-7/(FO-8 blank)

142

FO-2. Composite Electrical Electrical Schematic Diagram, Control Monitor C-9921/TSQ-97 (Sheet 3 of 3)

Change 1 FO-7 (FO-8 blank)

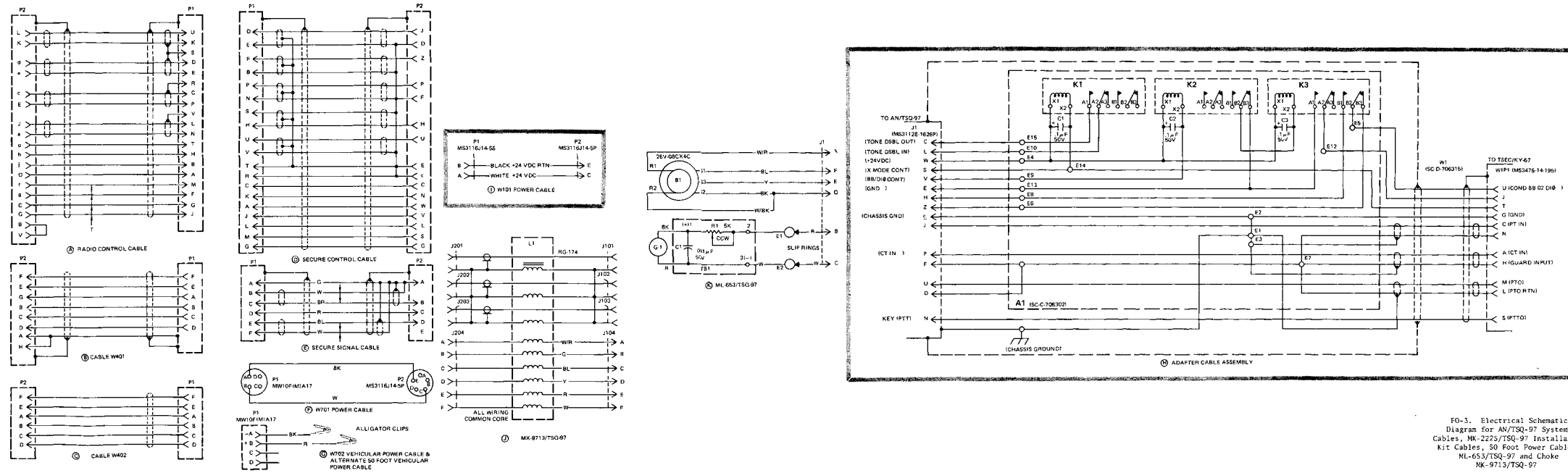

FO-3. Electrical Schematic Diagram for AN/TSQ-97 System Cables, MK-2225/TSQ-97 Installation Kit Cables, 50 Foot Power Cable, ML-653/TSQ-97 and Choke MK-9713/TSQ-97

Change 2 FO-9/(FO-10 blank)

FO-3. Electrical Schematic Diagram for AN/TSQ-97 System Cables
MK-2225/TSQ-97 Installation Kit Cables,
50 Foot Power Cable, ML-653/TSQ-97 and Choke
MK-9713/TSQ-97

Change 2 FO-9/ (FO-10 blank)

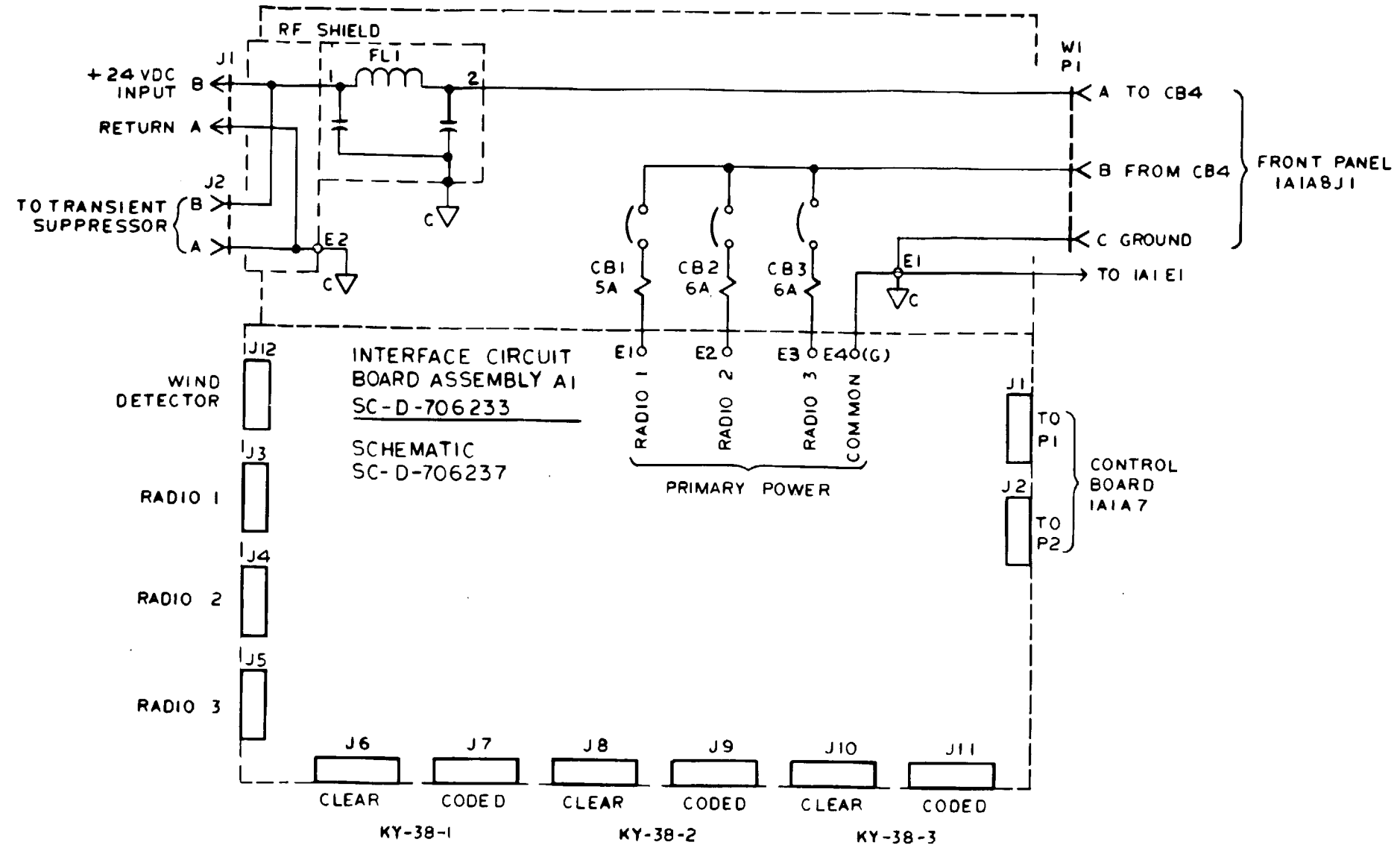

NOTES :

1. ∇ C INDICATES REAR PANEL GROUND
2. PARTIAL REFERENCE DESIGNATIONS SHOWN, PREFIX WITH IA1A9.
3. FOR FINAL ASSEMBLY, SEE SC-D-706223.

FO-4. Electrical Schematic Diagram, Rear Panel Assembly

FO-11/FO-12 Blank

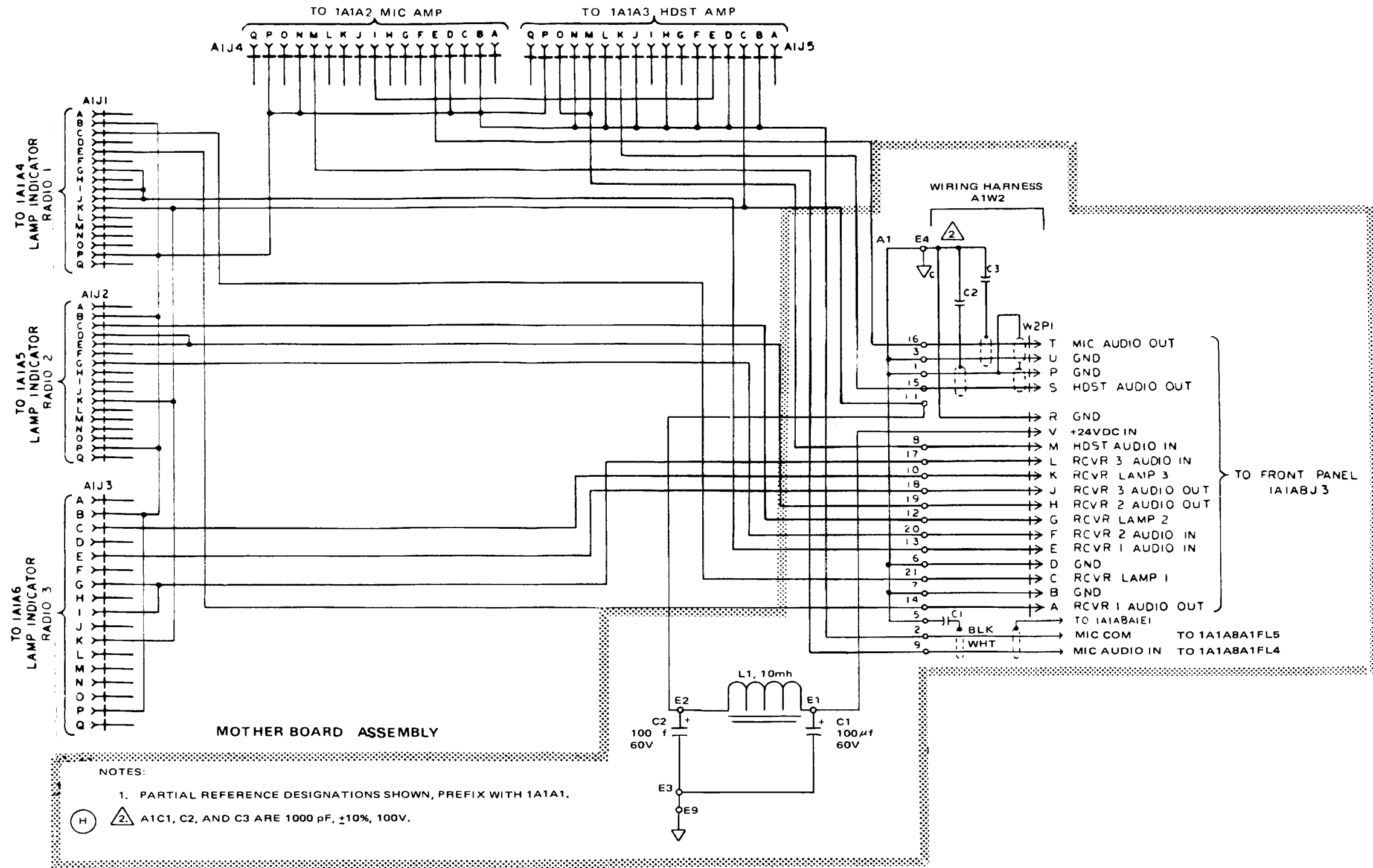

FO-5. Electrical Schematic Diagram, Card Enclosure Assembly 1A1A1

Change 1 FO-13/(FO-14 Blank)

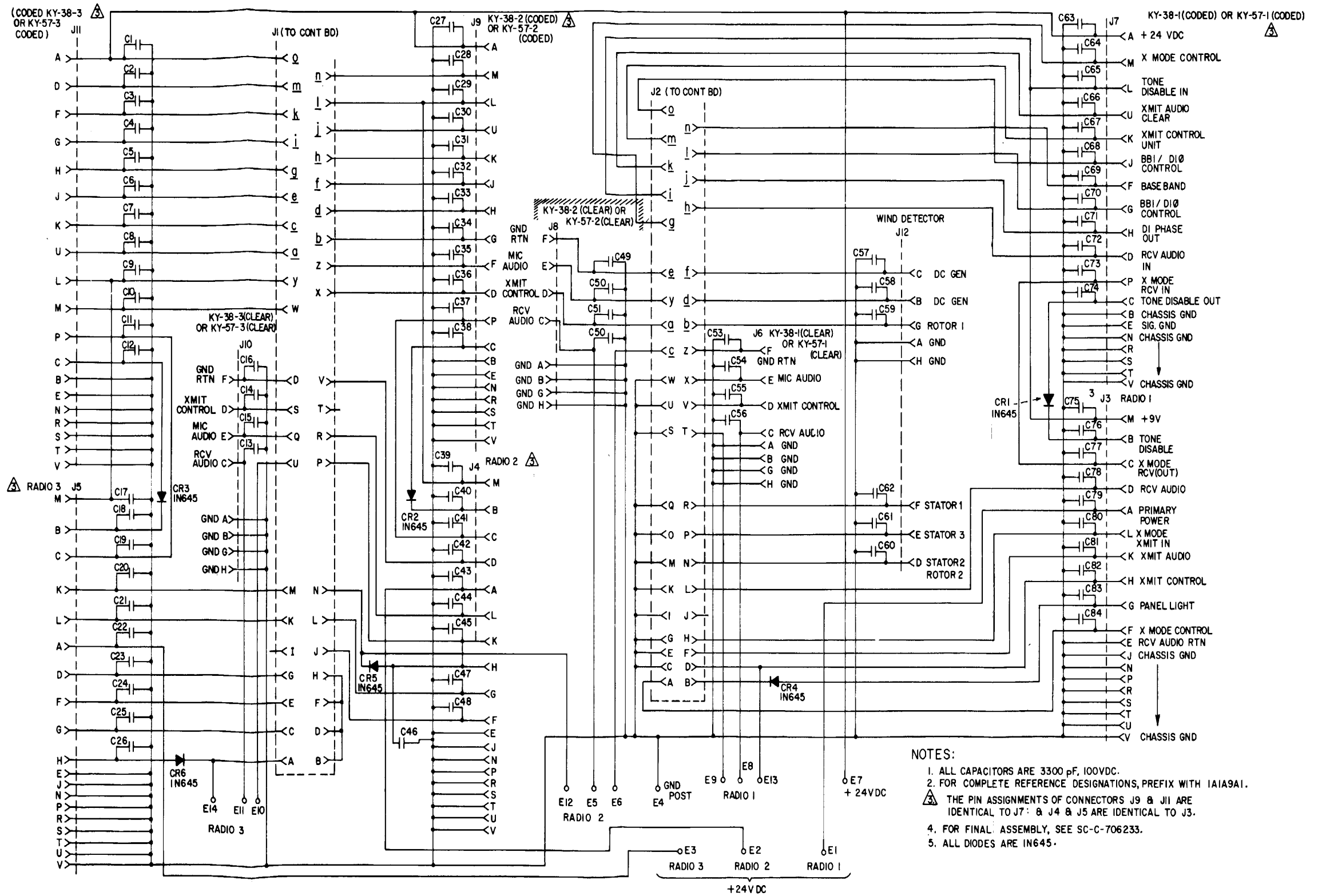

FO-6. Electric Schematic Diagram, Interface Circuit Cord Assembly 1A1A1A9

Change 2 FO15/(FO-16 Blank)

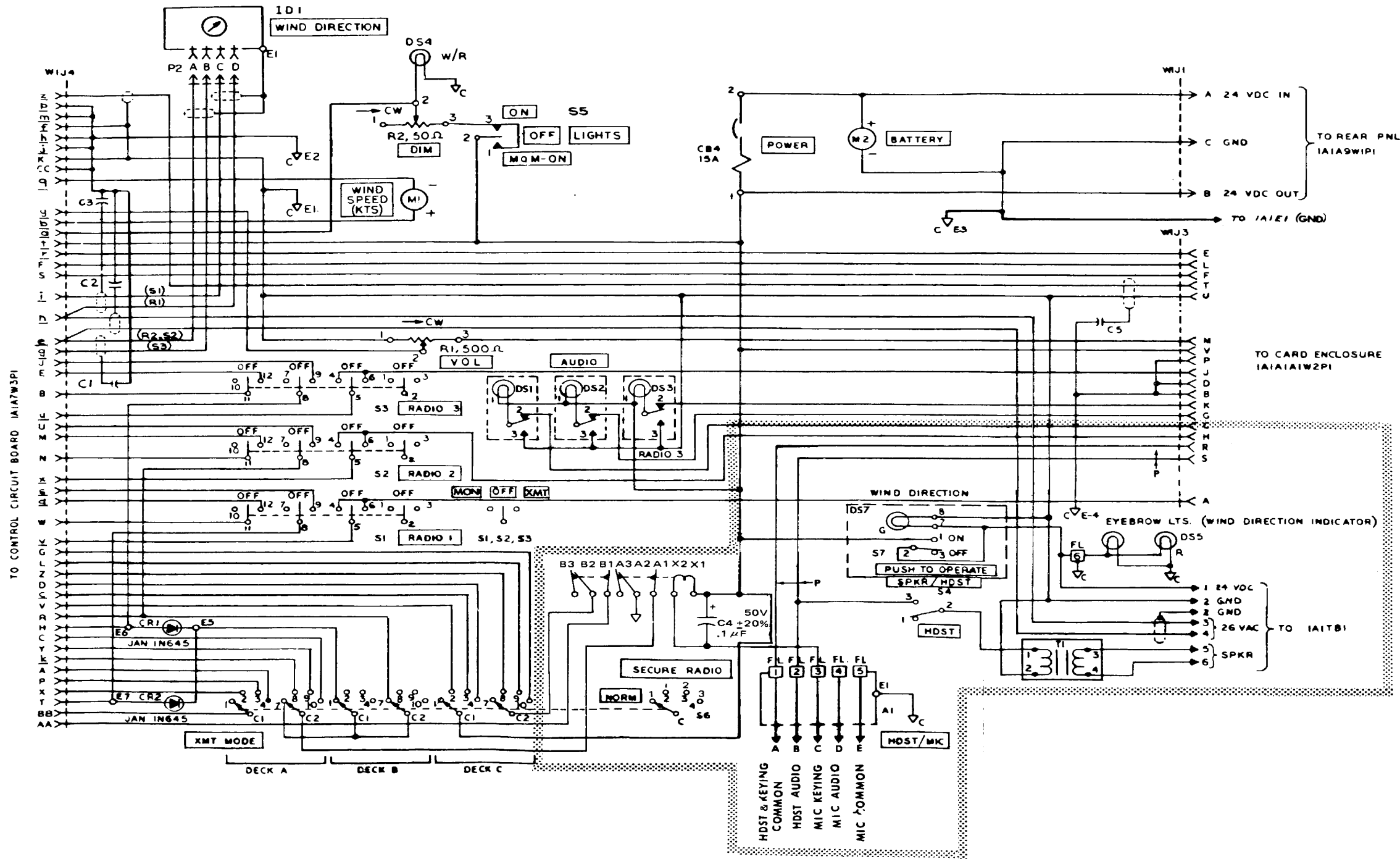
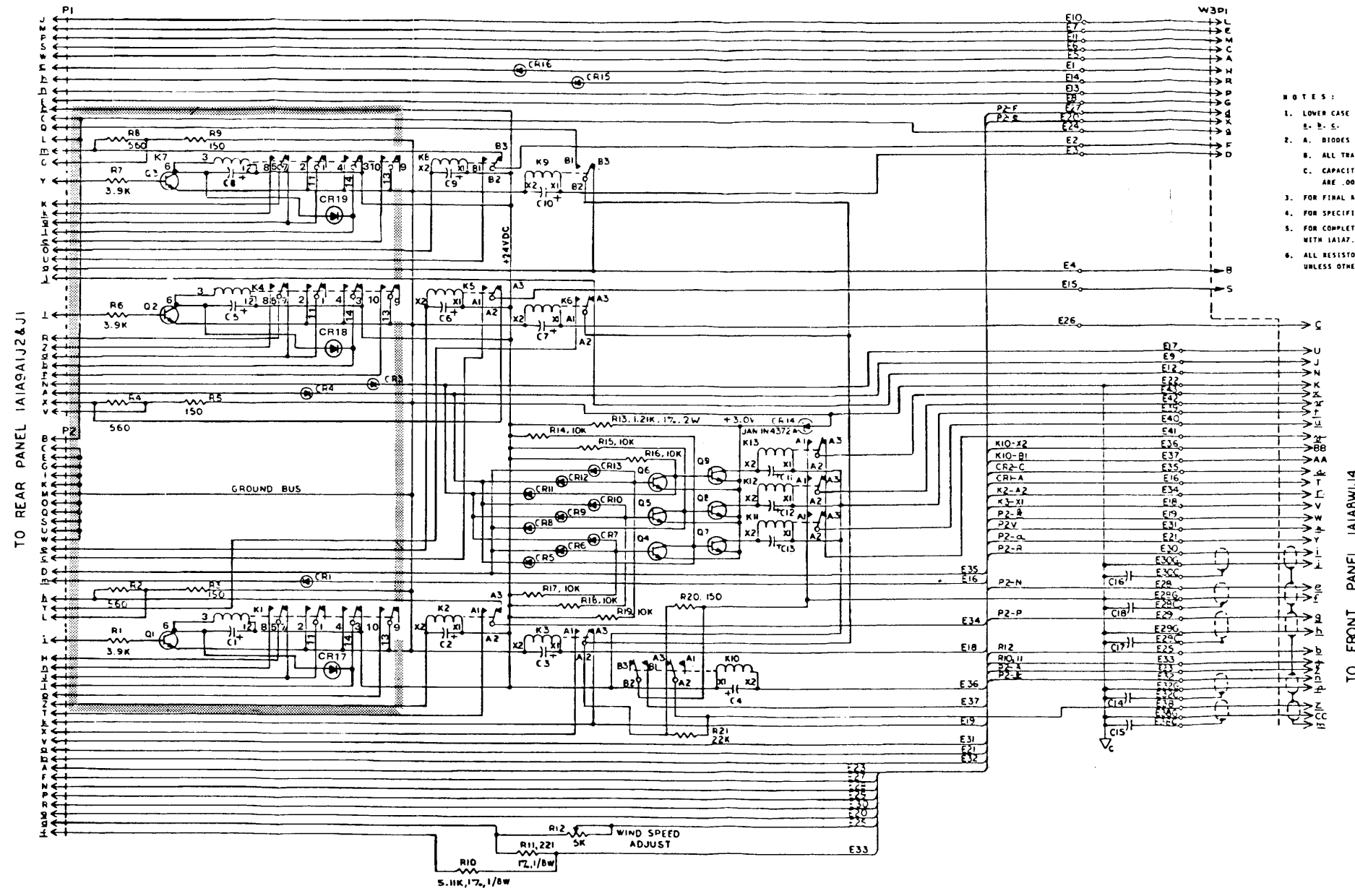

Figure FO-7. Electrical Schematic Diagram, Panel Assembly 1A1A8

Change 1 FO-17/(FO-18 blank)



- NOTES:
1. LOWER CASE LETTERS INDICATED BY UNDERLINE, I.E. S, E, E.
 2. A. DIODES CR1-13, 15, 16 ARE JAN 1N645.
B. ALL TRANSISTORS ARE JAN 2N1711.
C. CAPACITOR C1-13 ARE .1UF, 50V, 205 AND C14-16 ARE .001UF, 100V, 105.
 3. FOR FINAL ASSEMBLY, SEE SC-C-70622B.
 4. FOR SPECIFICATION, SEE SC-A-706330.
 5. FOR COMPLETE REFERENCE DESIGNATION, PREFIX WITH 1A1A7.
 6. ALL RESISTOR VALUES ARE IN OHMS, .5W, 1/4W UNLESS OTHERWISE STATED.

FO-8. Electrical Schematic Diagram, Control Board Assembly 1A1A7 (Earlier Systems)

Change 1 FO-19/(FO-20 blank)

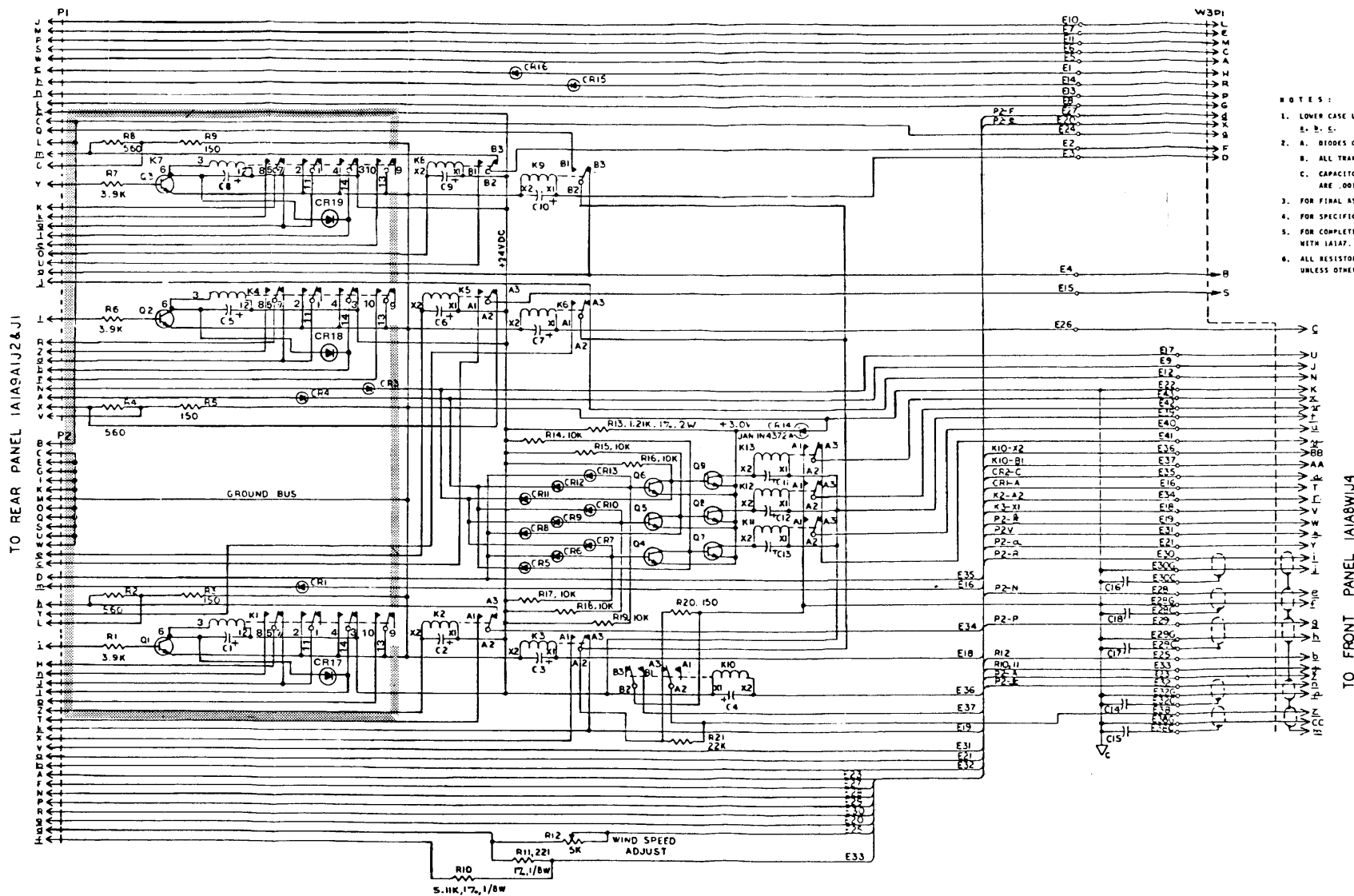

- NOTES:
1. LOWER CASE LETTERS INDICATED BY UNDERLINE, I.E. B-B-5.
 2. A. DIODES CR1-13, 15, 16 ARE JAN 1N445.
B. ALL TRANSISTORS ARE JAN 2N1713.
C. CAPACITOR C1-13 ARE .1UF, 50V, 205 AND C14-16 ARE .001UF, 100V, 10K.
 3. FOR FINAL ASSEMBLY, SEE SC-C-70622B.
 4. FOR SPECIFICATION, SEE SC-A-706330.
 5. FOR COMPLETE REFERENCE DESIGNATION, PREFIX WITH 1A1A7.
 6. ALL RESISTOR VALUES ARE IN OHMS, Ω , K, 1/K UNLESS OTHERWISE STATED.

FO-9. Electrical Schematic Diagram, Control Board Assembly 1A1A7 (Later Systems)

Change 1 FO-21/(FO-22 blank)

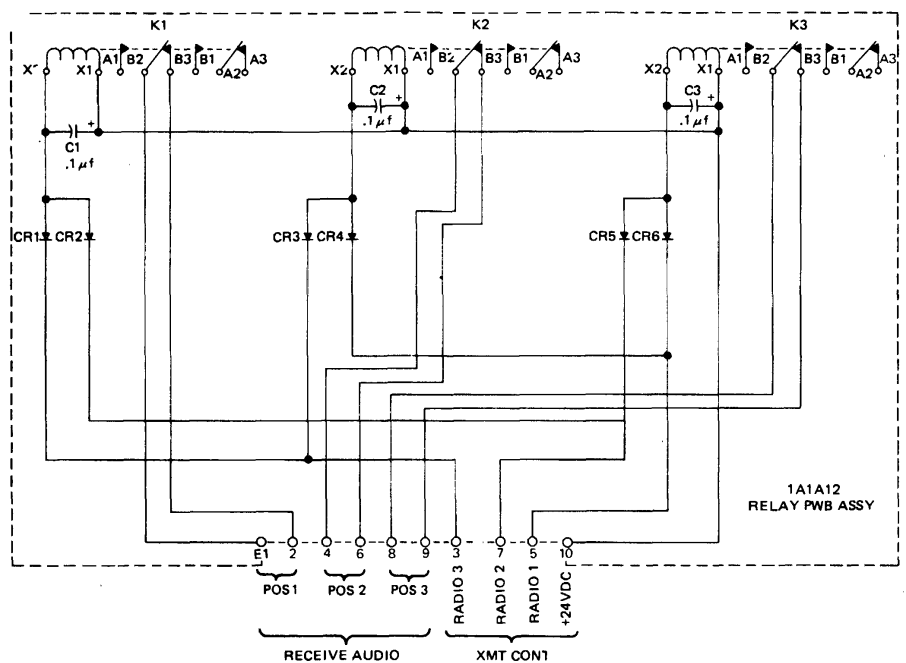

NOTES:

1. FOR FINAL ASSEMBLY, SEE SC-C-706050.
2. PARTIAL REFERENCE DESIGNATIONS ARE SHOWN, FOR COMPLETE DESIGNATION, PREFIX WITH 1A1A12.
3. ALL DIODES, CR1-CR6 ARE JAN1N645.
4. FOR SPECIFICATION, SEE SC-A-706048.

FO-10. Electrical Schematic Diagram, Relay Board Assembly 1A1A12

FO-10. Electrical Schematic Diagram, Relay Board Assembly 1A1A12

Change 1 FO-23/(FO-24 Blank)

RECOMMENDED CHANGES TO EQUIPMENT TECHNICAL PUBLICATIONS



THEN... JOT DOWN THE DOPE ABOUT IT ON THIS FORM, CAREFULLY TEAR IT OUT, FOLD IT AND DROP IT IN THE MAIL!

SOMETHING WRONG WITH THIS PUBLICATION?

FROM: (PRINT YOUR UNIT'S COMPLETE ADDRESS)

DATE SENT

PUBLICATION NUMBER

TM 11-5825-270-10

PUBLICATION DATE

23 Jul 81

PUBLICATION TITLE

Radio Frequency R-2176/FRN

BE EXACT... PIN-POINT WHERE IT IS

PAGE NO.	PARA-GRAPH	FIGURE NO.	TABLE NO.

IN THIS SPACE TELL WHAT IS WRONG AND WHAT SHOULD BE DONE ABOUT IT:

TEAR ALONG PERFORATED LINE

PRINTED NAME, GRADE OR TITLE, AND TELEPHONE NUMBER

SIGN HERE:

DA FORM 2028-2
1 JUL 79

PREVIOUS EDITIONS ARE OBSOLETE.

P.S.—IF YOUR OUTFIT WANTS TO KNOW ABOUT YOUR RECOMMENDATION MAKE A CARBON COPY OF THIS AND GIVE IT TO YOUR HEADQUARTERS.

By Order of the Secretary of the Army:

E. C. MEYER
General, United States Army
Chief of Staff

Official

J. C. PENNINGTON
Major General, United States Army
The Adjutant General

DISTRIBUTION:

Active Army:

HISA (Ft Monmouth) (21)
USAINSCOM (2)
COE (1)
TSG (1)
USAARENBD (1)
DARCOM (1)
TRADOC (2)
OS Maj Cmd (4)
TECOM (2)
USACC (4)
MDW (1)
Armies (2)
Corps (2)
Svc Colleges (1)
USASIGS (5)
USAADS (2)
USAFAS (2)
USAARMS(2)
USAIS (2)
USAES (2)

USAICS (3)
MAAG (1)
USARMIS (1)
USAERDAA (1)
USAERDAW (1)
Ft Gordon (10)
Ft Carson (5)
Army Dep (1) except
 LBAD (14)
 SAAD (30)
 TOAD (14)
 SHAD (3)
Ft Gillem (10)
USA Dep (1)
Sig Sec USA Dep (1)
Ft Richardson (CERCOM Ofc) (2)
Units org under fol TOE:
 29-207 (2)
 29-610 (2)

NG: None

USAR: None

For explanation of abbreviations used, see AR 310-50

